

OPTIREG™ linear voltage regulator TLS10xB0MB demoboard

Z8F61701244



Family
overview



Support

Preface

Scope and purpose

This document provides information about the usage of the demoboards for the voltage tracking regulator TLS10xB0MB in a PG-SCT595-5 package from Infineon Technologies AG. Please also refer to the corresponding datasheets.

Intended audience

This document is intended for engineers who develop applications.

Table of contents

	Preface	1
	Table of contents	2
1	Introduction	3
1.1	TLS10xB0MB family and features	3
1.2	Block diagram	4
2	Demoboard	5
2.1	Operating conditions	6
3	Schematic and layout	7
3.1	Schematic	7
3.2	Layout	8
4	Bill of materials	9
5	Restrictions	10
6	Revision history	11
	Disclaimer	12

1 Introduction

1 Introduction

1.1 TLS10xB0MB family and features

TLS10xB0MB family

Table 1 TLS10xB0MB family

Type	Package	Output current	Enable/Adjust
TLS102B0MB	PG-SCT595-5	20 mA	✓
TLS105B0MB	PG-SCT595-5	50 mA	✓

TLS10xB0MB features

- Very high accuracy voltage tracking
- Output voltage adjustable down to 2.0 V
- Very low dropout voltage
- Very low current consumption of typically 3 μ A in off mode
- Improved regulation loop:
 - Very fast regulation
 - Good stability characteristics
 - Small ceramic capacitor of 1 μ F at the output is required
- Internal protection features:
 - Output current limitation
 - Short circuit protected output (to GND and to battery)
 - Overtemperature shutdown
 - Reverse polarity protected input
- AEC qualified
- Green Product (RoHS compliant)

These features make the TLS10xB0MB voltage tracking regulators perfectly suitable as automotive sensor supply and as high precision supply for off-board loads.

1 Introduction

1.2 Block diagram

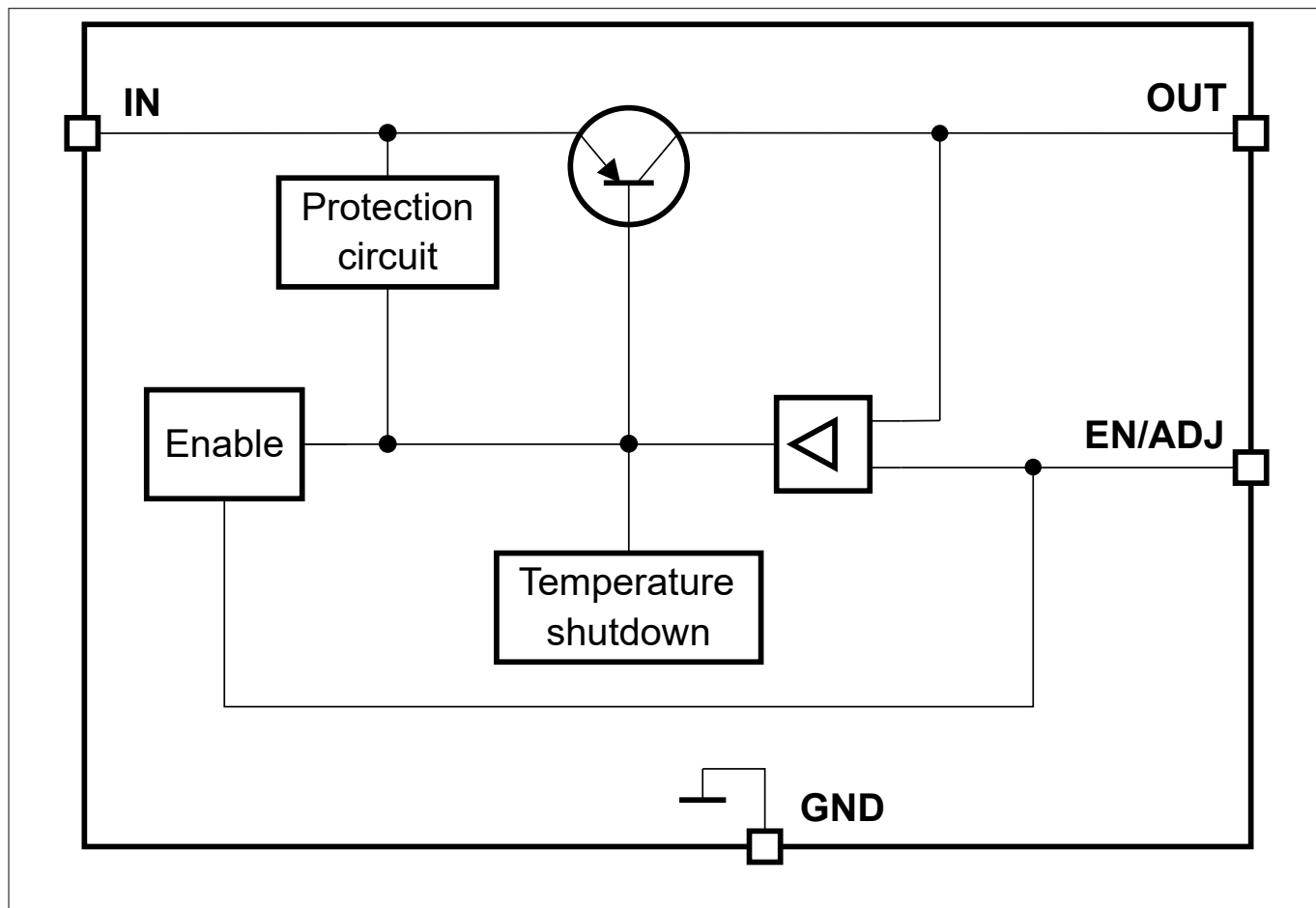

Figure 1 Block diagram TLS10xB0MB

2 Demoboard

2 Demoboard

The OPTIREG™ linear voltage regulator TLS10xB0MB demoboard is available for all devices of the TLS10xB0MB voltage tracking regulator family in a PG-SCT595-5 package, see [Table 1](#).

[Figure 2](#) shows the OPTIREG™ linear voltage regulator TLS10xB0MB demoboard.

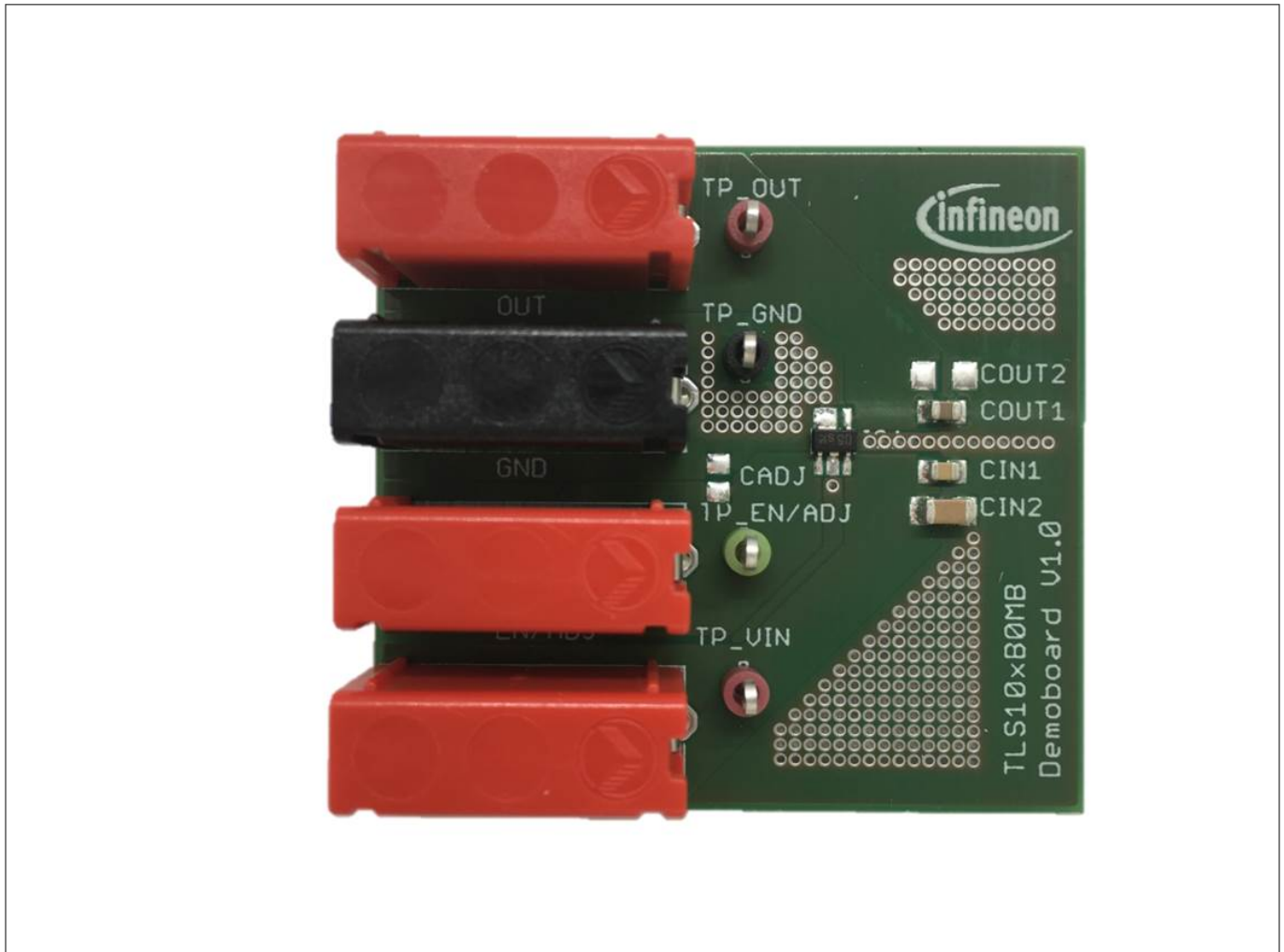

Figure 2 Demoboard

2 Demoboard

2.1 Operating conditions

To avoid electrical damage of the demoboard, the operating range defined in [Table 2](#) must be maintained.

Table 2 Limit values for operation¹⁾

Parameter	Pin	Maximum Ratings		Unit	Note
		Min.	Max.		
Board supply voltage	IN	-16	45	V	²⁾ Power supply
Enable/Adjust voltage	EN/ADJ	-0.3	45	V	³⁾ Tracked reference voltage
Regulator output voltage	OUT	-5	45	V	–
Input output voltage difference	VIN-VOUT	-30	45	V	–
Ground	GND	0	0	V	System GND

1) The demoboard operates at an ambient temperature of 25°C.

2) Functional input voltage range: 4 V to 45 V.

3) Functional ADJ voltage range: 2 V to 14V.

3 Schematic and layout

3 Schematic and layout

3.1 Schematic

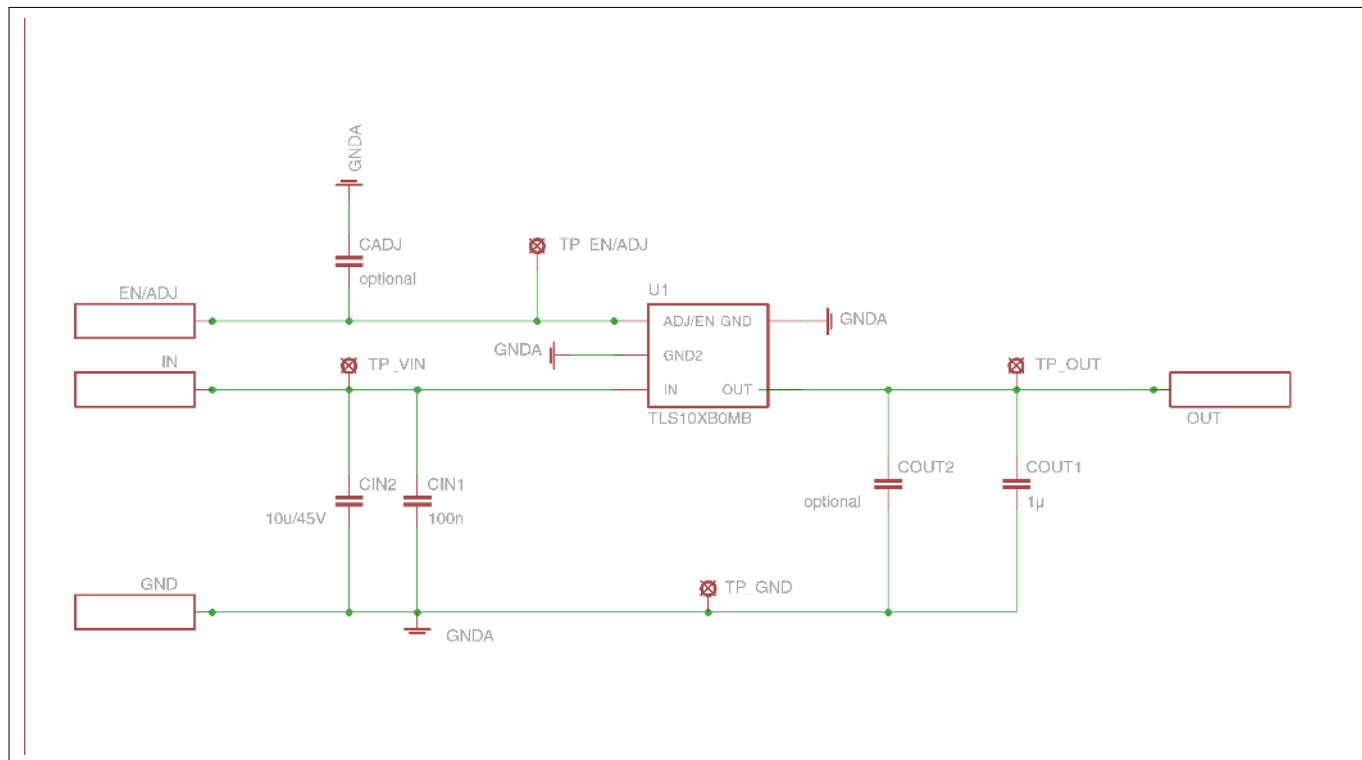

Figure 3 Schematic

3 Schematic and layout

3.2 Layout

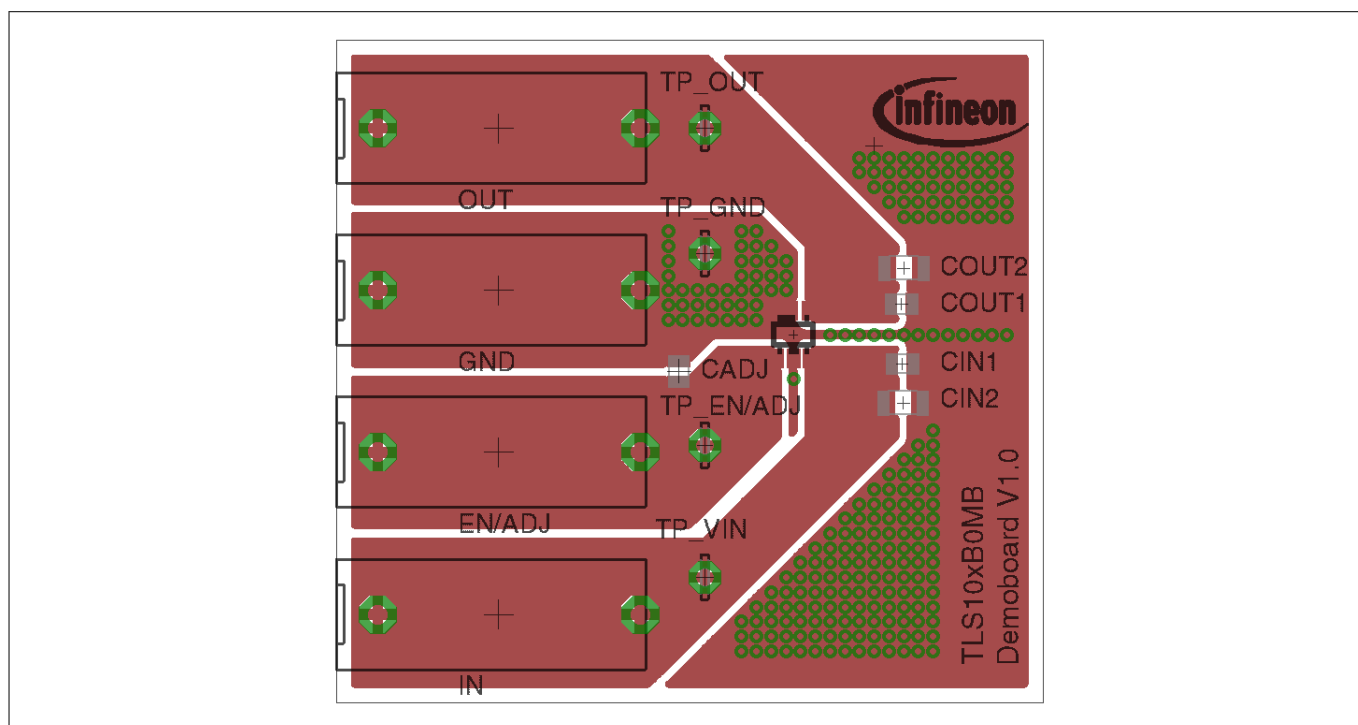

Figure 4 Top layer

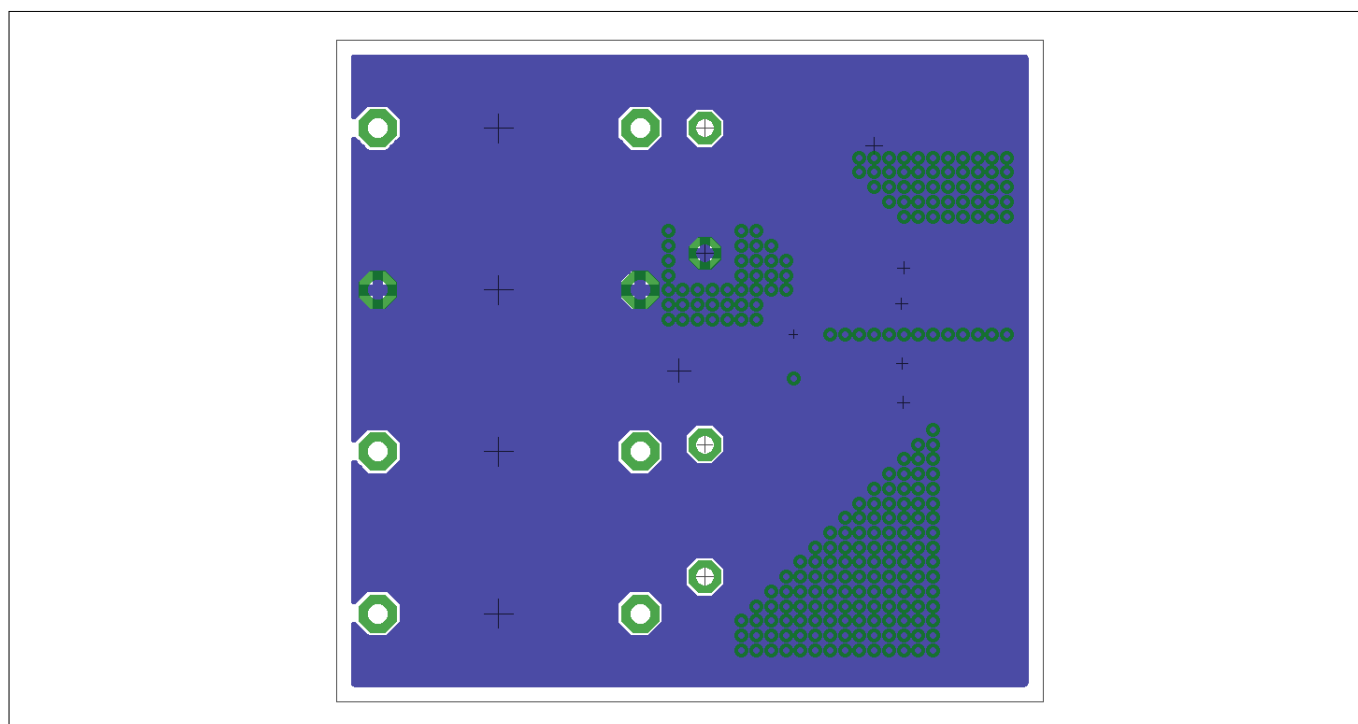

Figure 5 Bottom layer

4 Bill of materials

4 Bill of materials

Table 3 Bill of materials

Part	Value	Package
IN	Banana jack	BABU4MM
OUT	Banana jack	BABU4MM
EN/ADJ	Banana jack	BABU4MM
GND	Banana jack	BABU4MM
CIN1	100 nF	C0805
CIN2	10 μ F	C1206
COUT1	1 μ F	C0805
COUT2	n.a.	C1206
CADJ	n.a.	C0805
TP_VIN	Test point VIN	–
TP_EN/ADJ	Test point EN/ADJ	–
TP_OUT	Test point OUT	–
TP_GND	Test point GND	–

5 Restrictions

This demoboard offers limited features only for evaluation and testing of Infineon products. The demoboard is not an end product or finished appliance, nor is it intended or authorized by Infineon to be integrated into end products. The demoboard may not be used in any production system.

For further information please contact www.infineon.com.

6 Revision history

6 Revision history

Revision	Date	Changes
1.02	2022-11-28	Editorial changes
1.01	2021-02-11	Editorial changes
1.0	2018-04-13	Document created

Trademarks

All referenced product or service names and trademarks are the property of their respective owners.

Edition 2022-11-28

Published by

Infineon Technologies AG

81726 Munich, Germany

© 2022 Infineon Technologies AG

All Rights Reserved.

Do you have a question about any aspect of this document?

Email: erratum@infineon.com

Document reference

IFX-Z8F61701244

Important notice

The information given in this document shall in no event be regarded as a guarantee of conditions or characteristics ("Beschaffheitsgarantie").

With respect to any examples, hints or any typical values stated herein and/or any information regarding the application of the product, Infineon Technologies hereby disclaims any and all warranties and liabilities of any kind, including without limitation warranties of non-infringement of intellectual property rights of any third party.

In addition, any information given in this document is subject to customer's compliance with its obligations stated in this document and any applicable legal requirements, norms and standards concerning customer's products and any use of the product of Infineon Technologies in customer's applications.

The data contained in this document is exclusively intended for technically trained staff. It is the responsibility of customer's technical departments to evaluate the suitability of the product for the intended application and the completeness of the product information given in this document with respect to such application.

Warnings

Due to technical requirements products may contain dangerous substances. For information on the types in question please contact your nearest Infineon Technologies office.

Except as otherwise explicitly approved by Infineon Technologies in a written document signed by authorized representatives of Infineon Technologies, Infineon Technologies' products may not be used in any applications where a failure of the product or any consequences of the use thereof can reasonably be expected to result in personal injury.