

ATLANTIC VERSION TERMINATOR INTERFACE ADAPTER	PART NUMBER	REVISION	DESCRIPTION	FEED TYPE	APPLICATOR STYLE CONVERSION CHART					
	2151548-1	A	FINE CRIMP HEIGHT ADJUST	MECHANICAL	PNEUMATIC FEED		PART NUMBERS REQUIRED			
					2119950-1	1338685-1	5-18022-5	2119641-1	2119799-1	2063440-1
	2151548-2	A	FINE CRIMP HEIGHT ADJUST	PNEUMATIC	MECHANICAL FEED					
					2119949-1	1338685-1	5-18022-5	2119653-1	-	-
					2119951-1	-	8-2151548-5	1901094-3	-	2168400-6 (QUANTITY 2)
	2151548-5	A	FINE CRIMP HEIGHT ADJUST	SERVO LATCH PLATE ⁴	MECHANICAL FEED					
					2119949-1	1338685-1	5-18022-5	2119653-1	-	-
2151548-6	A	NON-CRIMP HEIGHT ADJUST	SERVO LATCH PLATE ⁴	PNEUMATIC FEED						
				2119950-1	1338685-1	5-18022-5	2119641-1	2119799-1	2063440-1	
2151548-7	A	FINE CRIMP HEIGHT ADJUST	NONE	-	-	-	-	-	-	-
7-2151548-7	A	CRIMP TOOLING KIT	-	-	-	-	-	-	-	-

APPLICATOR DATA		
CRIMP	SIZE	TYPE
WIRE	1.78 mm [.070]	F
INSUL	2.79 mm [.110]	F
APPLICATOR INSTRUCTIONS 408-10389		

TERMINAL DATA: G&H (Lear) TERMINAL TE CRIMP SPECIFICATION	
TERMINAL NAME: CON12	
WIRE STRIP LENGTH .142-.157 IN [3.60-4.00 mm]	INSULATION DIAMETER RANGE Ø.005-.100 IN [0.14-2.55 mm]
TERMINAL APPLICATION SPECIFICATION	NONE
TERMINALS APPLIED	
TE TERMINAL 2113247-1	G&H (Lear) TERMINAL 26623.213.178

WIRE SIZE	CRIMP HEIGHT mm [INCH]	CRIMP HEIGHT REFERENCE SETTING
20 AWG OR 0.50mm2	1.15+/-0.05 [.045+/- .002]	6.8
0.35mm2	1.10+/-0.05 [.043+/- .002]	7.3

- RECOMMENDED SPARE PARTS
- GREASE BEARING SURFACES LIGHTLY
- 3. LUBRICATE DAILY PER THE APPLICATOR INSTRUCTION SHEET SUPPLIED WITH THE APPLICATOR.
- APPLICATOR SPECIFIC DATA TO BE ENTERED INTO BLANK MEMORY CHIP AT ASSEMBLY. SEE BELOW FOR PART NUMBER:
MECHANICAL FEED WITH "SMART APPLICATOR" CONVERSION: 8-2151548-4
PNEUMATIC FEED WITH "SMART APPLICATOR" CONVERSION: 8-2151548-4
SERVO FEED WITH "FINE CRIMP HEIGHT ADJUST": 8-2151548-5
SERVO FEED WITH "NON-CRIMP HEIGHT ADJUST": 8-2151548-6
- 5. ADJUSTMENT OF THE STRIPPER MAY BE REQUIRED WHEN MOVING THE APPLICATOR BETWEEN BENCH AND LEADMAKER APPLICATIONS.
- APPLY PART NUMBER 1-23419-5 LOCTITE TO THREADS OF ITEM 50.
- GREASE THREADS, GROOVE AND O-RING ON ITEMS 35 & 252.
- MAGNET, ITEM 166 MUST BE ORIENTED CORRECTLY IN ORDER TO PROPERLY ACTUATE THE COUNTER.
- CRIMP HEIGHT REFERENCE SETTING WAS THE SETTING USED WHEN THE APPLICATOR WAS QUALIFIED AT THE FACTORY. ADJUSTMENT MAY BE NECESSARY WHEN RUNNING APPLICATOR IN THE FIELD.
- SPARE FEED CAM STORAGE LOCATION REFER TO INSTRUCTION SHEET FOR ADDITIONAL INFORMATION.
- TO CONVERT THE APPLICATOR TO A NON-CARRIER CUTTING STYLE, REMOVE ITEM 13 AND ATTACH TO THE LOCATION ON THE BACK SIDE OF THE HOUSING. REFER TO INSTRUCTION SHEET FOR ADDITIONAL INFORMATION.
- WHEN ASSEMBLING -6 NON-CRIMP HEIGHT ADJUST APPLICATOR USE SHIM PACK 2119957-2 TO ALIGN APPLICATOR'S MAXIMUM WIRE CRIMP HEIGHT AT NORMAL TERMINATOR SHUT HEIGHT

***WARNING**
ON INSTALLATION, SET WIRE DISC, ITEM 40 TO LARGEST WIRE SIZE SETTING. USE OF SETTINGS BELOW MINIMUM REQUIRED CRIMP HEIGHT SETTING WILL CAUSE DAMAGE TO CRIMP TOOLING.

-77	-7	-6	-5	-2	-1	PART NO	DESCRIPTION	ITEM NO
-	-	1	-	-	-	2119957-2	APPLICATOR SHIM PACK	260
-	1	-	1	1	1	8-21084-0	O-RING, .676 ID, .070 DIA. MAT.	252
-	-	-	-	1	-	2119640-1	PUSH ROD, AIR FEED	250
-	-	-	-	1	-	2079988-1	BUSHING, LCH5-12, MISUMI	249
-	-	-	-	1	-	2119641-1	FEED CAM, AIR FEED	248
-	1	-	1	1	1	2119798-1	DETENT PIN	247
-	1	-	1	1	1	1-22279-3	SPRING, COMPRESSION	246
-	-	1	-	-	-	2119758-1	RAM, AMP STYLE, SIDE FEED, NON-ADJ.	245

ATLANTIC VERSION
Shown on sheets 1 of 4 & 2 of 4
(Pacific version shown on sheets 3 of 4 & 4 of 4)

SET UP GAUGE	LOC	DIST	REVISIONS				
2119599-1	A	66	P LTR	DESCRIPTION	DATE	DWN	APVD
			A	RELEASED	13FEB2012	RH	SX

-	1	1	1	1	1	2119082-9	CAM, SNAIL, INSULATION ADJUSTMENT	244	
-	1	1	1	1	1	2079764-1	WASHER, WAVE SPRING, CREST-TO-CREST	243	
-	1	1	1	1	1	2119083-1	RETAINER, INSULATION DIAL	242	
-	1	1	1	1	1	18023-1	SCR, SKT HD CAP M3 X 5.0	241	
-	-	2	2	-	-	2168400-6	SHCS, LOW HEAD, RoHS, M5 X 16	240	
-	-	-	-	-	1	2119580-1	MECHANICAL FEED ASSEMBLY	239	
-	-	-	-	-	1	2063440-1	AIR FEED MODULE	238	
-	-	1	1	-	-	2119740-2	TAG, IDENTIFICATION	213	
-	-	1	1	-	-	1901094-3	SPACER, FEEDER	198	
-	1	1	1	1	1	993111-1	PIN, SLOTTED SPRING 3.0 X 20.0	177	
-	1	1	1	1	1	8-22280-7	SPRING, COMPRESSION	176	
-	1	1	1	1	1	1752353-2	GUIDE PIN, HOLDDOWN	175	
-	1	1	1	1	1	1901680-2	GUIDE PIN, HOLDDOWN	174	
-	-	-	-	-	2	21045-3	RING, RETAIN, EXTERN, 3/16 CRESCENT	172	
-	1	1	1	1	1	994969-1	MAGNET, RARE EARTH HIGH ENERGY	166	
-	REF	REF	REF	REF	REF	994970-2	COUNTER, MAGNETIC	164	
-	-	-	-	-	1	240638-1	SPRING, FEED FINGER	163	
-	-	-	-	-	1	3-23627-7	PIN, RETAIN, GRVD, 3/16 X .854	137	
-	-	-	-	-	1	2119799-1	HOLDER, FEED FINGER, AF	136	
-	-	REF	REF	-	-	SEE NOTE 4	MEMORY CHIP, PROGRAMMED	135	
-	-	1	1	-	-	1633743-1	SERVO FEED LATCH ASM	133	
-	1	1	1	1	1	1-18028-2	WASHER, FLAT, REG M4	119	
-	-	REF	REF	-	-	2119944-1	FEED FINGER ASSEMBLY, SF	117	
-	1	1	1	1	1	455888-5	SPACER, CRIMPER	82	
-	1	1	1	1	1	5-547505-2	SPRING, COMPRESSION	77	
-	1	1	1	1	1	854769-4	HOLDER, INS	74	
-	1	1	1	1	1	2119956-1	DOCUMENTATION PACKAGE	71	
-	1	-	-	-	1	2119740-1	TAG, IDENTIFICATION	67	
-	2	2	2	2	2	2168078-1	SCREW, DRIVE, RH, RoHS	66	
-	1	-	1	1	1	2119793-1	LIMITER, ADJUSTMENT BOLT	63	
-	3	-	3	3	3	992763-5	SCR, SET, SOC, CONE POINT, M3 x 4.0	62	
-	1	1	1	1	1	2079383-4	SCR, BHSC, RoHS (M4 X 8)	60	
-	-	-	-	-	1	5-18022-5	SCR, HEX HD CAP, M4 X 6.0	59	
-	1	1	1	1	1	21028-2	PIN, SLOTTED SPRING .062 X .250	58	
-	-	-	-	-	1	1338685-1	PAWL, FEED	56	
-	4	4	4	4	4	2168400-1	SHCS, LOW HEAD, RoHS, M4 X 12	54	
-	1	1	1	1	1	1-5018030-0	NUT, HEX, REG, RoHS, M3.5	52	
-	1	1	1	1	1	2-1901681-1	HOLDDOWN, TERMINAL	51	
-	1	1	1	1	1	2-1752354-1	STANDOFF, HOLD-DOWN	50	
-	-	-	-	-	1	2	18023-9	SCR, SKT HD CAP M4 X 6.0	49
-	-	-	-	-	-	1	2119652-1	FEED CAM, PRE FEED	48
-	-	-	-	-	-	1	2119653-1	FEED CAM, POST FEED	47
-	1	1	1	1	1	2119656-9	APPLICATOR BASIC ASSEMBLY, SF	46	
-	1	-	1	1	1	2119370-1	RAM, AMP STYLE, SIDE FEED	44	
-	1	1	1	1	1	2079383-7	SCR, BHSC, RoHS (M8 X 25)	41	
-	1	-	1	1	1	2119645-1	DISC, NUMBERED FA WIRE ADJUSTMENT	40	
-	1	-	1	1	1	2119957-1	APPLICATOR SHIM PACK	39	
-	1	1	1	1	1	2119644-1	RAM WASHER, PRECISION	38	
-	1	1	1	1	1	2119085-1	FA HEAD, ATLANTIC STYLE	37	
-	1	-	1	1	1	2119092-1	BOLT, ADJUSTMENT	35	
-	1	1	1	1	1	2-1752356-0	SUPPORT, TERMINAL	34	
-	2	2	2	2	2	2079383-5	SCR, BHSC, RoHS (M4 X 20)	33	
-	1	1	1	1	1	2161328-1	HEX HEAD, FLANGED, M5 x 8mm LONG	32	
-	1	1	1	1	1	1320908-3	SPACER, STRIP GUIDE	30	
-	1	1	1	1	1	2119959-1	ASSEMBLY, STRIP GUIDE	29	
-	1	1	1	1	1	1-455888-0	SPACER, CRIMPER	28	
-	1	1	1	1	1	1320928-6	PLATE, STRIP GUIDE	24	
-	1	1	1	1	1	2168083-2	SCR, SKT HD CAP, RoHS, M4 X 8.0	21	
-	1	1	1	1	1	1-18028-2	WASHER, FLAT, REG M4	20	
-	1	1	1	1	1	2119533-1	STRIPPER, SIDE FEED	19	
-	1	1	1	1	1	2119806-1	INSERT, SHEAR	13	
-	1	1	1	1	1	3-22280-3	SPRING, COMPRESSION	12	
-	1	1	1	1	1	1-356885-4	STOP, SHEAR	11	
-	1	1	1	1	1	2119805-1	SHEAR HOLDER, FRONT	10	
-	1	1	1	1	1	462006-6	FLOATING SHEAR, FRONT	9	
-	1	1	1	1	1	1633919-2	ANVIL, COMBINATION	8	
-	-	-	-	-	-	-	-	7	
-	-	-	-	-	-	-	-	6	
-	1	1	1	1	1	2119780-9	DEPRESSOR, SHEAR	5	
-	1	1	1	1	1	2-238011-2	BLOCK, CRIMPER SPACER	4	
-	1	1	1	1	1	1-1633962-3	CRIMPER, INSULATION F PREMIUM	3	
-	1	1	1	1	1	455888-4	SPACER, CRIMPER	2	
-	1	1	1	1	1	1-456404-8	CRIMPER, WIRE PREMIUM	1	

DIMENSIONS:		TOLERANCES UNLESS OTHERWISE SPECIFIED:		DWN		CHK		APVD		NAME	
mm	9 PLC ±.5	PLC ±.13	5 PLC ±.013	4 PLC ±.0001	FINISH	28DEC2011	28DEC2011	28DEC2011	28DEC2011	TE Connectivity	TE Connectivity Harrisburg, PA 17105-3608
MATERIAL		FINISH		WEIGHT		SCALE		SHEET		REV	
						1:2		1 OF 4		A	

LOC	DIST	REV	DATE	BY	APPD
A	66				

FEED TYPE MECHANICAL

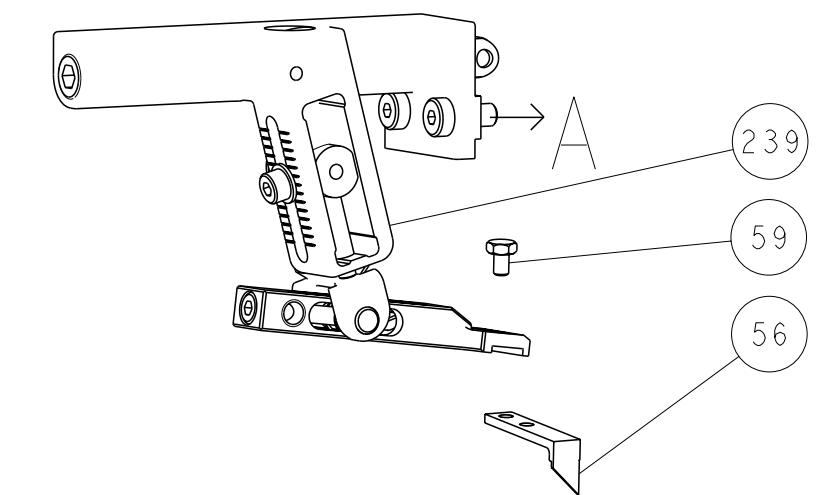

PNEUMATIC

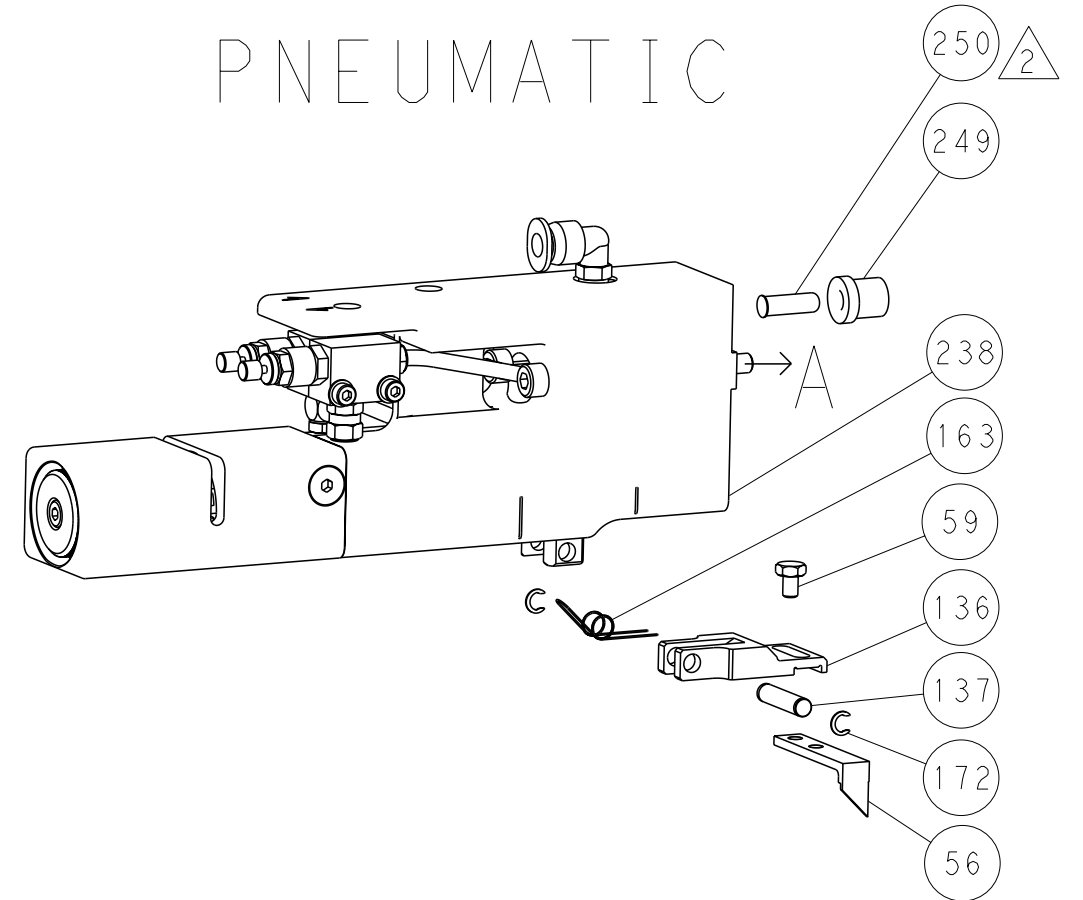

SERVO LATCH PLATE

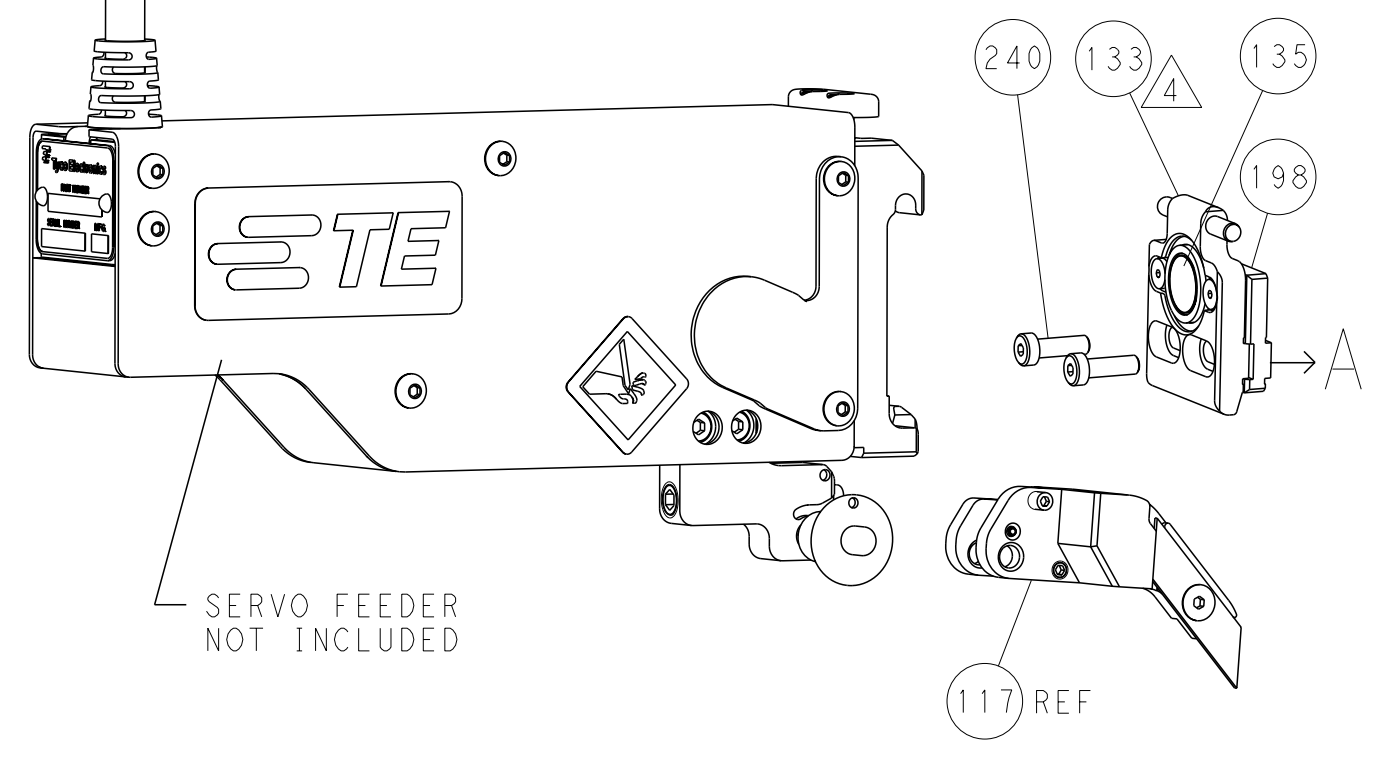

CAM POSITIONS

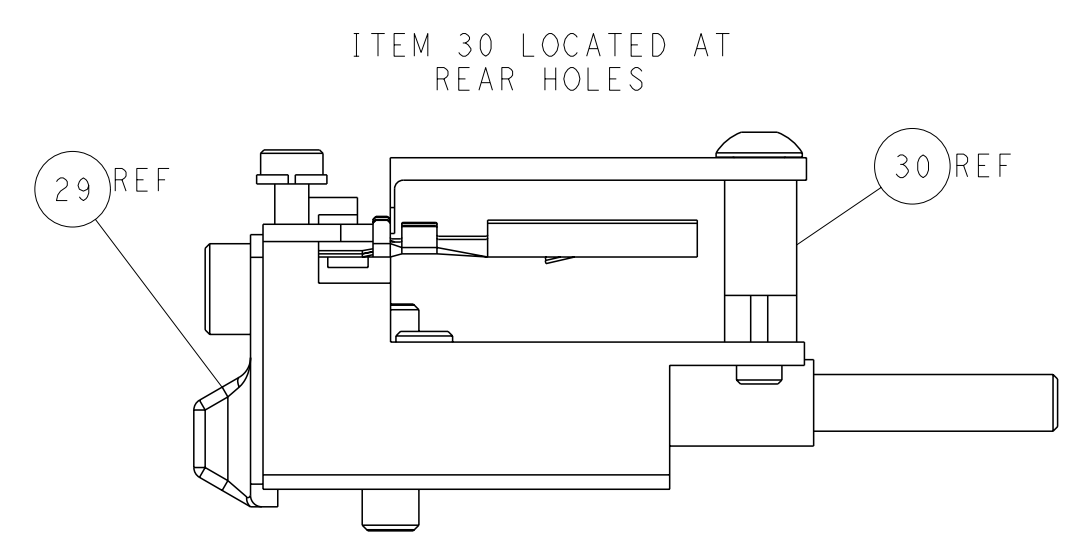
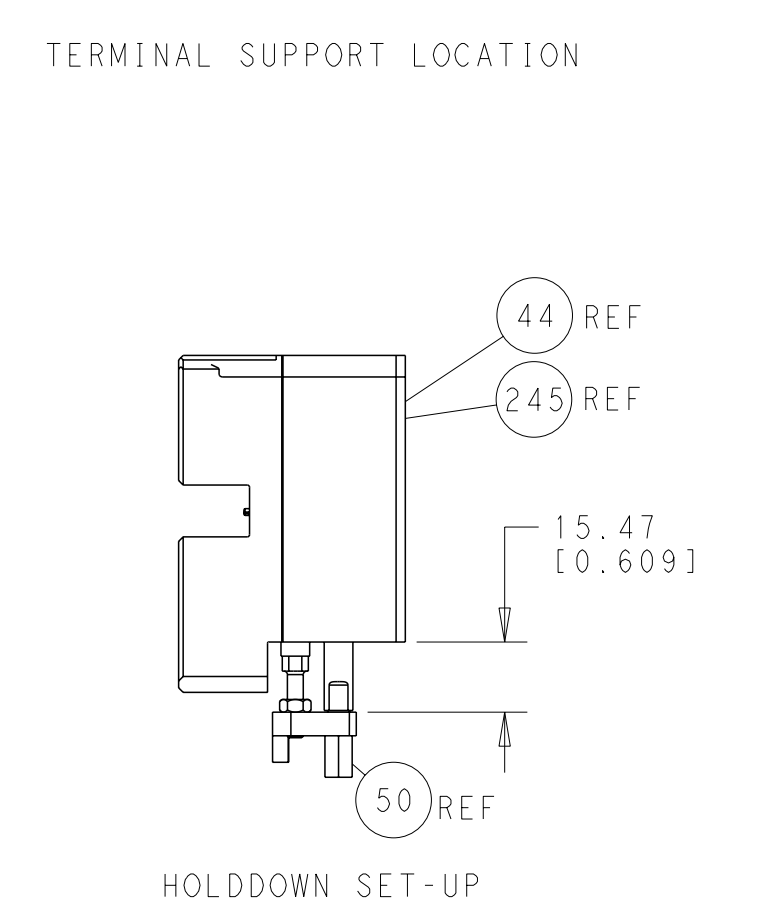
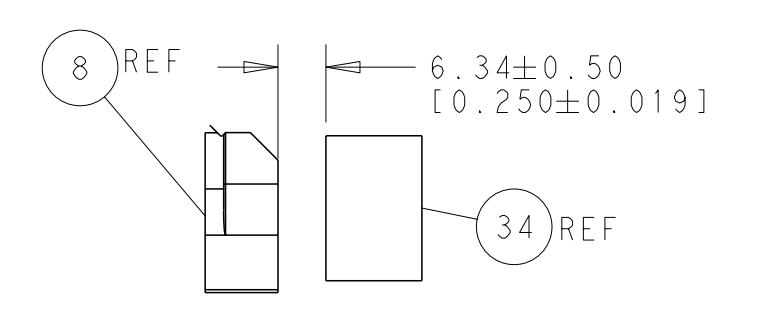
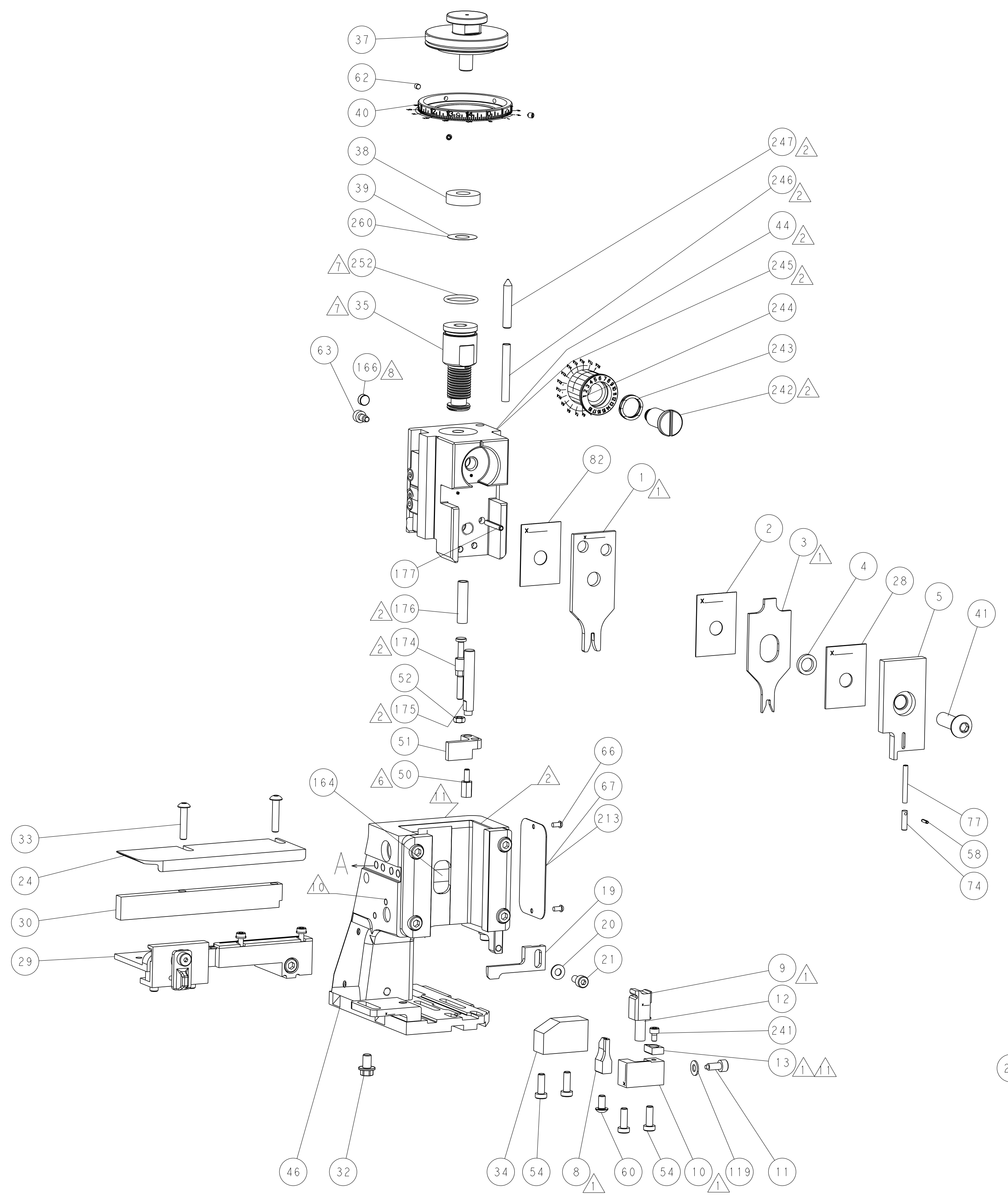
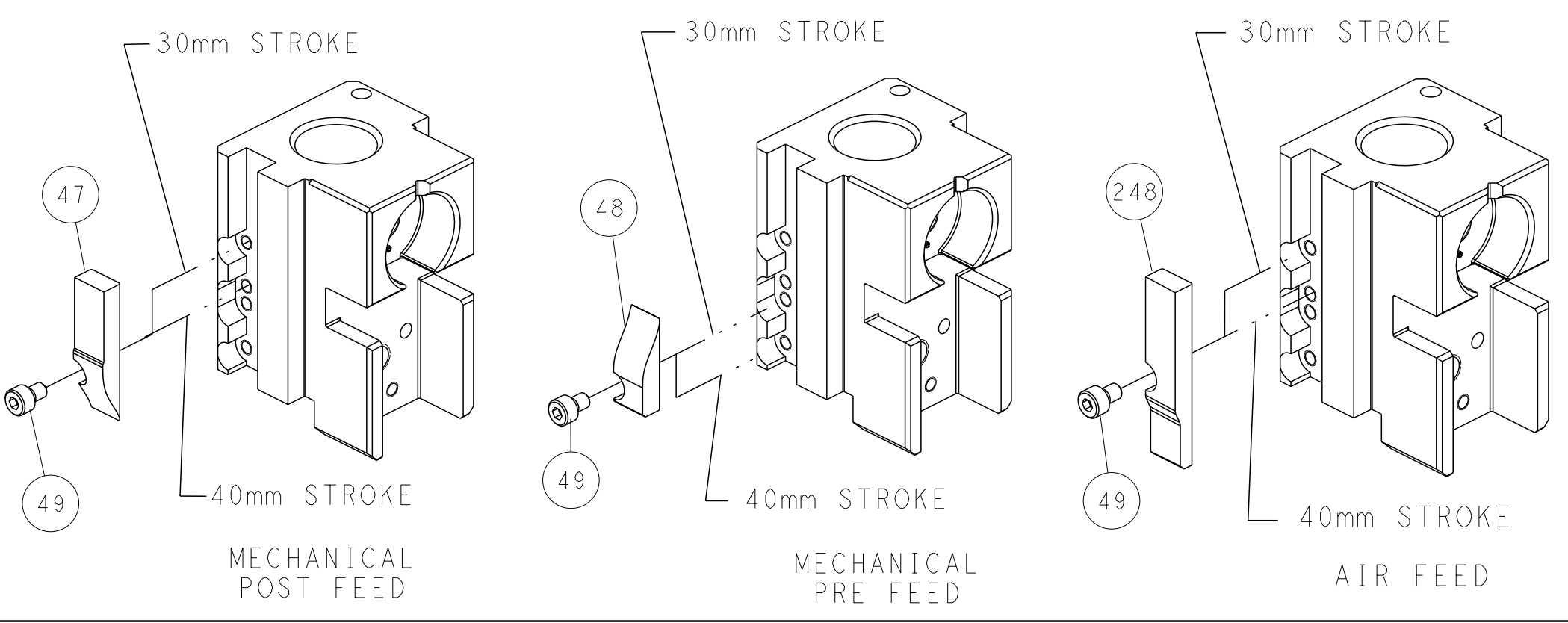

ATLANTIC VERSION
 Shown on sheets 1 of 4 & 2 of 4
 (Pacific version shown on sheets 3 of 4 & 4 of 4)

DIMENSIONS: mm 		TOLERANCES UNLESS OTHERWISE SPECIFIED: 9 PLC ±0.5 1 PLC ±0.5 2 PLC ±0.13 3 PLC ±0.13 4 PLC ±0.001 ANGLES ±0.0001		DWN R. HUANG 28DEC2011 CHK S.XI 28DEC2011 APVD J. CRUZ 28DEC2011		NAME Ocean Side Feed Applicator	
MATERIAL:		FINISH:		WEIGHT:		SIZE CAGE CODE DRAWING NO. RESTRICTED TO A11 00779 C-2151548	
CUSTOMER ACCESSIBLE PRODUCTION DRAWING				SCALE 1:2		SHEET 2 OF 4 REV A	

PACIFIC VERSION TERMINATOR INTERFACE ADAPTER	PART NUMBER	REVISION	DESCRIPTION	FEED TYPE	APPLICATOR STYLE CONVERSION CHART						
					CONVERT TO	PART NUMBERS REQUIRED					
						PNEUMATIC FEED	2119950-1	1338685-1	5-18022-5	2119641-2	2119799-1
	2-2151548-1	A	FINE CRIMP HEIGHT ADJUST	MECHANICAL	SERVO LATCH PLATE	2119951-1	-	8-2151548-5	1901094-3	-	2168400-6 (QUANTITY 2)
					SMART APPLICATOR	2161326-1	-	8-2151548-4	-	-	-
					MECHANICAL FEED	2119949-1	1338685-1	5-18022-5	2119653-2	-	-
	2-2151548-2	A	FINE CRIMP HEIGHT ADJUST	PNEUMATIC	SERVO LATCH PLATE	2119951-1	-	8-2151548-5	1901094-3	-	2168400-6 (QUANTITY 2)
					SMART APPLICATOR	2161326-1	-	8-2151548-4	-	-	-
					MECHANICAL FEED	2119949-1	1338685-1	5-18022-5	2119653-2	-	-
	2-2151548-5	A	FINE CRIMP HEIGHT ADJUST	SERVO LATCH PLATE	PNEUMATIC FEED	2119950-1	1338685-1	5-18022-5	2119641-2	2119799-1	2063440-1
					-	-	-	-	-	-	-
	2-2151548-7	A	FINE CRIMP HEIGHT ADJUST	NONE	-	-	-	-	-	-	-
	7-2151548-7	A	CRIMP TOOLING KIT	-	-	-	-	-	-	-	-

APPLICATOR DATA		
CRIMP	SIZE	TYPE
WIRE	1.78 mm [.070]	F
INSUL	2.79 mm [.110]	F
APPLICATOR INSTRUCTIONS 408-10389		

TERMINAL DATA: G&H (Lear) TERMINAL TE CRIMP SPECIFICATION			
TERMINAL NAME: CON12			
WIRE STRIP LENGTH .142-.157 IN [3.60-4.00 mm]		INSULATION DIAMETER RANGE Ø.005-.100 IN [0.14-2.55 mm]	
TERMINAL APPLICATION SPECIFICATION	NONE	-	-
TERMINALS APPLIED			
TE TERMINAL	G&H (Lear) TERMINAL	TE TERMINAL	G&H (Lear) TERMINAL
2113247-1	26623.213.178		

WIRE SIZE	CRIMP HEIGHT mm [INCH]	CRIMP HEIGHT REFERENCE SETTING
20 AWG OR 0.50mm ²	1.15+/-0.05 [.045+/- .002]	6.8
0.35mm ²	1.10+/-0.05 [.043+/- .002]	7.3



- RECOMMENDED SPARE PARTS
- GREASE BEARING SURFACES LIGHTLY
- LUBRICATE DAILY PER THE APPLICATOR INSTRUCTION SHEET SUPPLIED WITH THE APPLICATOR.
- APPLICATOR SPECIFIC DATA TO BE ENTERED INTO BLANK MEMORY CHIP AT ASSEMBLY. SEE BELOW FOR PART NUMBER:
 MECHANICAL FEED WITH "SMART APPLICATOR" CONVERSION: 8-2151548-4
 PNEUMATIC FEED WITH "SMART APPLICATOR" CONVERSION: 8-2151548-4
 SERVO FEED WITH "FINE CRIMP HEIGHT ADJUST": 8-2151548-5
- ADJUSTMENT OF THE STRIPPER MAY BE REQUIRED WHEN MOVING THE APPLICATOR BETWEEN BENCH AND LEADMAKER APPLICATIONS.
- APPLY PART NUMBER 1-23419-5 LOCTITE TO THREADS OF ITEM 50.
- GREASE THREADS, GROOVE AND O-RING ON ITEMS 139 & 152.
- MAGNET MUST BE ORIENTED CORRECTLY IN ORDER TO PROPERLY ACTUATE THE COUNTER.
- CRIMP HEIGHT REFERENCE SETTING WAS THE SETTING USED WHEN THE APPLICATOR WAS QUALIFIED AT THE FACTORY. ADJUSTMENT MAY BE NECESSARY WHEN RUNNING APPLICATOR IN THE FIELD.
- SPARE FEED CAM STORAGE LOCATION REFER TO INSTRUCTION SHEET FOR ADDITIONAL INFORMATION.
- TO CONVERT THE APPLICATOR TO A NON-CARRIER CUTTING STYLE, REMOVE ITEM 13 AND ATTACH TO THE LOCATION ON BACK SIDE OF THE HOUSING. REFER TO INSTRUCTION SHEET FOR ADDITIONAL INFORMATION.

***WARNING**
 ON INSTALLATION, SET WIRE DISC, ITEM 40 TO LARGEST WIRE SIZE SETTING. USE OF SETTINGS BELOW MINIMUM REQUIRED CRIMP HEIGHT SETTING WILL CAUSE DAMAGE TO CRIMP TOOLING.

-77	-27	-25	-22	-21	PART NO	DESCRIPTION	ITEM NO
-	1	1	1	1	2119782-1	FINE ADJUST HEAD ASM, PACIFIC STYLE	251
-	-	-	1	-	2119640-1	PUSH ROD, AIR FEED	250
-	-	-	1	-	2079988-1	BUSHING, LCH5-12, MISUMI	249
-	1	1	1	1	1-22279-3	SPRING, COMPRESSION	246
-	1	1	1	1	2119082-9	CAM, SNAIL, INSULATION ADJUSTMENT	244
-	1	1	1	1	2079764-1	WASHER, WAVE SPRING, CREST-TO-CREST	243

PACIFIC VERSION
 Shown on sheets 3 of 4 & 4 of 4
 (Atlantic version shown on sheets 1 of 4 & 2 of 4)

SET UP GAUGE	LOC	DIST	REVISIONS			
2119599-1	A	66	REV	DATE	BY	APPD
-	-	-	1	-	-	-
SEE SHEET 1			-	-	-	-

-	1	1	1	1	2119083-1	RETAINER, INSULATION DIAL	242
-	1	1	1	1	18023-1	SCR, SKT HD CAP M3 X 5.0	241
-	-	2	-	-	2168400-6	SHCS, LOW HEAD, RoHS, M5 X 16	240
-	-	-	-	1	2119580-1	MECHANICAL FEED ASSEMBLY	239
-	-	-	1	-	2063440-1	AIR FEED MODULE	238
-	-	1	-	-	2119740-2	TAG IDENTIFICATION	213
-	-	1	-	-	1901094-3	SPACER, FEEDER	198
-	1	1	1	1	993111-1	PIN, SLOTTED SPRING 3.0 X 20.0	177
-	1	1	1	1	8-22280-7	SPRING, COMPRESSION	176
-	1	1	1	1	1752353-2	GUIDE PIN, HOLDDOWN	175
-	1	1	1	1	1901680-2	GUIDE PIN, HOLDDOWN	174
-	-	-	2	-	21045-3	RING, RETAIN, EXTERN, 3/16 CRESCENT	172
-	1	1	1	1	994969-1	MAGNET, RARE EARTH HIGH ENERGY	166
-	REF	REF	REF	REF	994970-2	COUNTER, MAGNETIC	164
-	-	-	1	-	240638-1	SPRING, FEED FINGER	163
-	1	1	1	1	8-21084-1	O-RING, .801 ID, .070 DIA, MAT.	152
-	-	-	1	-	2119641-2	FEED CAM, AIR FEED	151
-	1	1	1	1	2119798-2	DETENT PIN	145
-	1	1	1	1	2079383-8	SCR, BHSC, RoHS (M4 X 16)	144
-	4	4	4	4	2168400-5	SHCS, LOW HEAD, RoHS, M4 X 20	143
-	-	-	-	1	2119653-2	FEED CAM, POST FEED	142
-	1	1	1	1	1-2119656-0	APPLICATOR BASIC ASSEMBLY, SF	141
-	1	1	1	1	2119650-1	RAM, ASIAN STYLE, SIDE FEED	140
-	1	1	1	1	2119092-2	BOLT, ADJUSTMENT	139
-	-	-	1	-	3-23627-7	PIN, RETAIN, GRVD, 3/16 X .854	137
-	-	-	1	-	2119799-1	HOLDER, FEED FINGER, AF	136
-	-	REF	-	-	SEE NOTE 4	MEMORY CHIP, PROGRAMMED	135
-	-	1	-	-	1633743-1	SERVO FEED LATCH ASM	133
-	1	1	1	1	1-18028-2	WASHER, FLAT, REG M4	119
-	-	REF	-	-	2119944-1	FEED FINGER ASSEMBLY, SF	117
-	1	1	1	1	455888-5	SPACER, CRIMPER	82
-	1	1	1	1	5-547505-2	SPRING, COMPRESSION	77
-	1	1	1	1	854769-4	HOLDER, INS	74
-	1	1	1	1	2119956-1	DOCUMENTATION PACKAGE	71
-	1	-	1	1	2119740-1	TAG IDENTIFICATION	67
-	2	2	2	2	2168078-1	SCREW, DRIVE, RH, RoHS	66
-	1	1	1	1	2119793-1	LIMITER, ADJUSTMENT BOLT	63
-	3	3	3	3	992763-5	SCR, SET, SOC, CONE POINT, M3 x 4.0	62
-	-	-	1	1	5-18022-5	SCR, HEX HD CAP, M4 X 6.0	59
-	1	1	1	1	21028-2	PIN, SLOTTED SPRING .062 X .250	58
-	-	-	1	1	1338685-1	PAWL, FEED	56
-	1	1	1	1	1-5018030-0	NUT, HEX, REG, RoHS, M3.5	52
-	1	1	1	1	2-1901681-1	HOLDDOWN, TERMINAL	51
-	1	1	1	1	2-1752354-1	STANDOFF, HOLD-DOWN	50
-	-	-	1	2	18023-9	SCR, SKT HD CAP M4 X 6.0	49
-	-	-	-	1	2119652-1	FEED CAM, PRE FEED	48
-	1	1	1	1	2079383-7	SCR, BHSC, RoHS (M8 X 25)	41
-	1	1	1	1	2119645-1	DISC, NUMBERED FA WIRE ADJUSTMENT	40
-	1	1	1	1	2119957-1	APPLICATOR SHIM PACK	39
-	1	1	1	1	2119644-1	RAM WASHER, PRECISION	38
-	1	1	1	1	2-1752356-0	SUPPORT, TERMINAL	34
-	2	2	2	2	2079383-5	SCR, BHSC, RoHS (M4 X 20)	33
-	1	1	1	1	2161328-1	HEX HEAD, FLANGED, M5 x 8mm LONG	32
-	1	1	1	1	1320908-3	SPACER, STRIP GUIDE	30
-	1	1	1	1	2119959-1	ASSEMBLY, STRIP GUIDE	29
-	1	1	1	1	1-455888-0	SPACER, CRIMPER	28
-	1	1	1	1	1320928-6	PLATE, STRIP GUIDE	24
-	1	1	1	1	2168083-2	SCR, SKT HD CAP, RoHS, M4 X 8.0	21
-	1	1	1	1	1-18028-2	WASHER, FLAT, REG M4	20
-	1	1	1	1	2119533-1	STRIPPER, SIDE FEED	19
-	1	1	1	1	2119806-1	INSERT, SHEAR	13
-	1	1	1	1	3-22280-3	SPRING, COMPRESSION	12
-	1	1	1	1	1-356885-4	STOP, SHEAR	11
-	1	1	1	1	2119805-1	SHEAR HOLDER, FRONT	10
-	1	1	1	1	462006-6	FLOATING SHEAR, FRONT	9
-	1	1	1	1	1633919-2	ANVIL, COMBINATION	8
-	-	-	-	-	-	-	7
-	-	-	-	-	-	-	6
-	1	1	1	1	2119780-9	DEPRESSOR, SHEAR	5
-	1	1	1	1	2-238011-2	BLOCK, CRIMPER SPACER	4
-	1	1	1	1	1-1633962-3	CRIMPER, INSULATION F PREMIUM	3
-	1	1	1	1	455888-4	SPACER, CRIMPER	2
-	1	1	1	1	1-456404-8	CRIMPER, WIRE PREMIUM	1

DIMENSIONS:		TOLERANCES UNLESS OTHERWISE SPECIFIED:		DRAWING NO	
mm	9 PLC ±.5	1 PLC ±0.5	2 PLC ±0.13	3 PLC ±0.013	4 PLC ±0.001
MATERIAL:		FINISH:		WEIGHT:	
-		-		-	

CHK	DATE	NAME	SCALE	SHEET	REV
H. HUANG	28DEC2011		1:2	3	A
S. XI	28DEC2011				
L. CRUZ	28DEC2011				

STE	TE Connectivity
Ocean Side Feed Applicator	
CAGE CODE: 00779	
DRAWING NO: C=2151548	
CUSTOMER ACCESSIBLE PRODUCTION DRAWING	

LOC	DIST	REV	DESCRIPTION	DATE	DWN	APVD
A	66		SEE SHEET 1			

FEED TYPE MECHANICAL

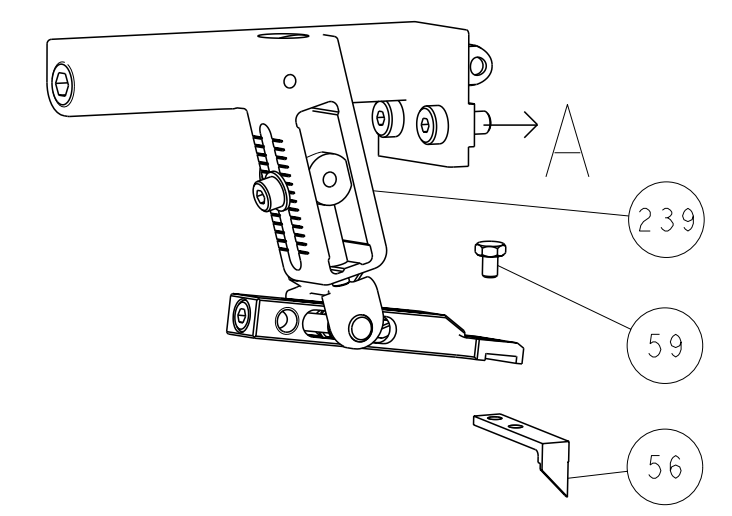

PNEUMATIC

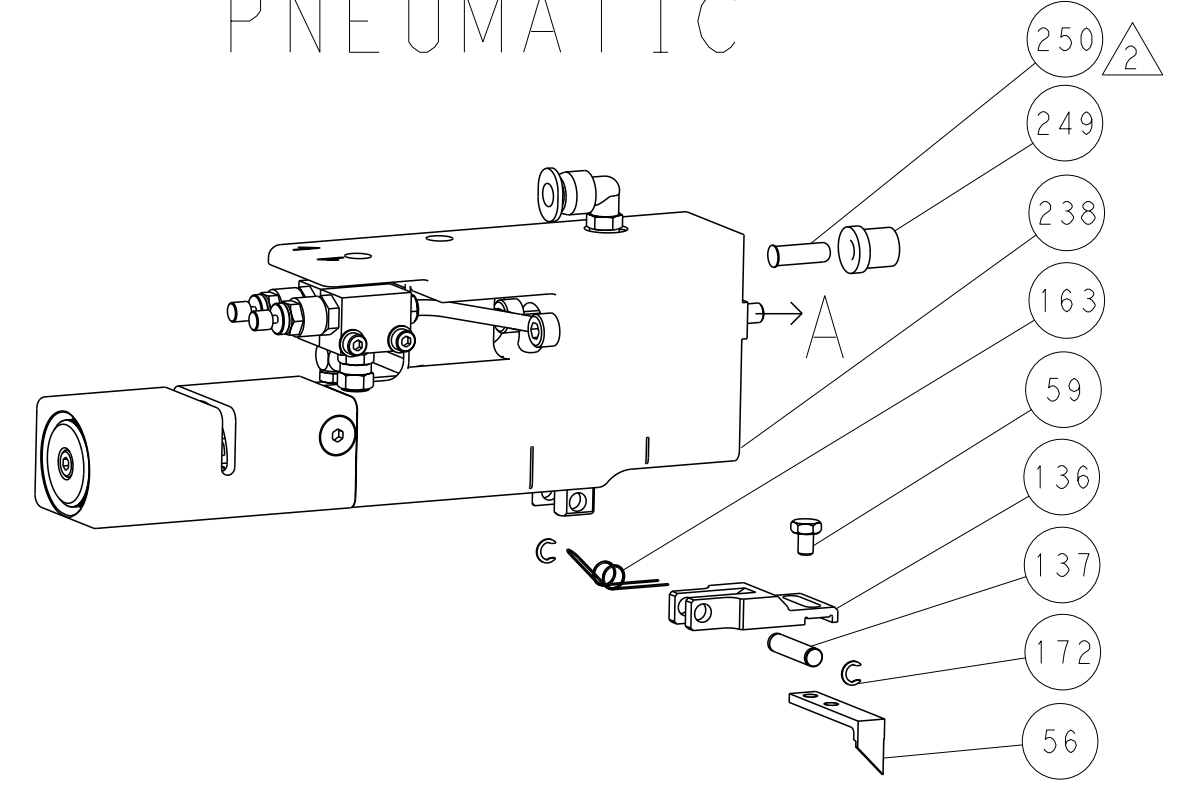

SERVO LATCH PLATE

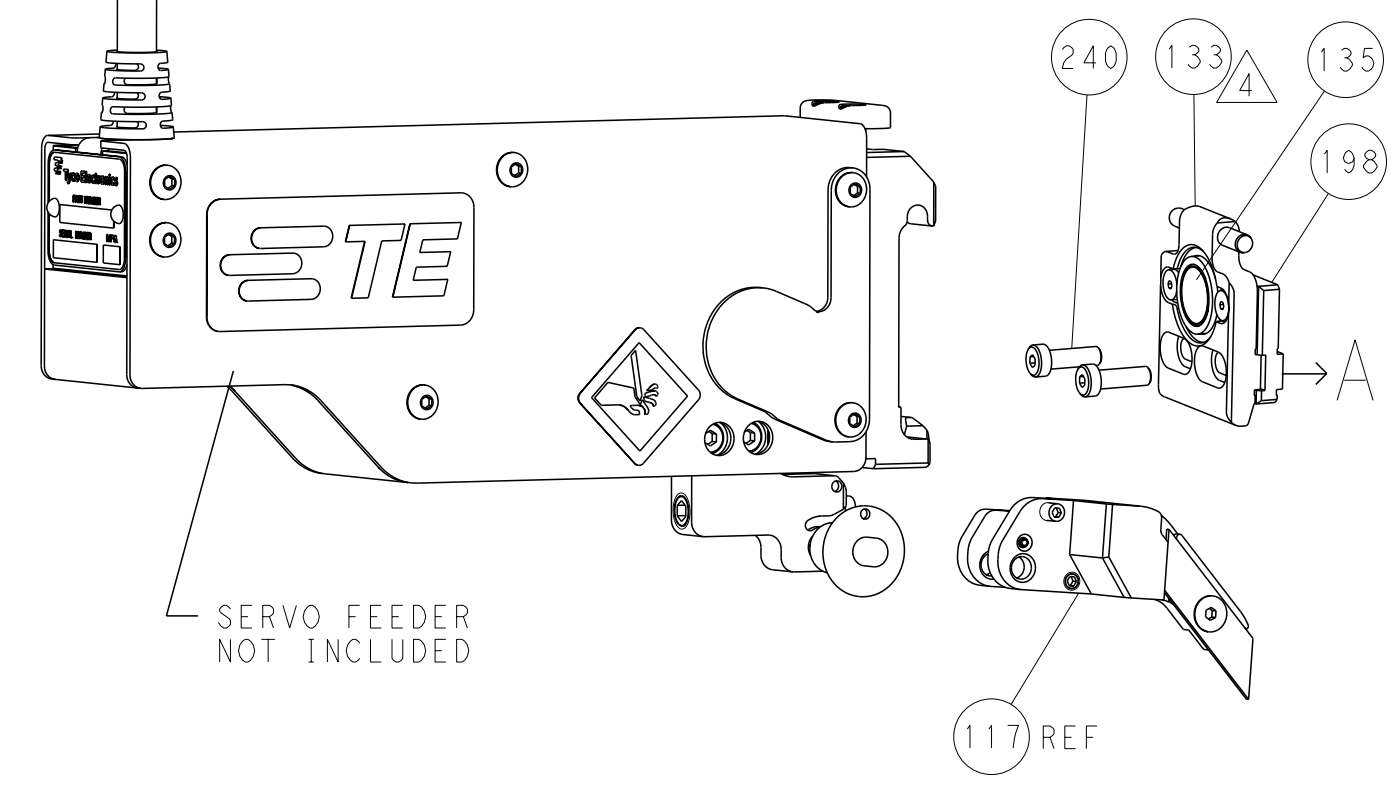

CAM POSITIONS

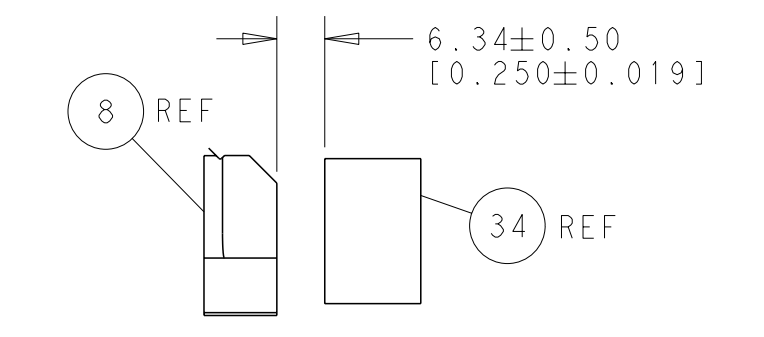
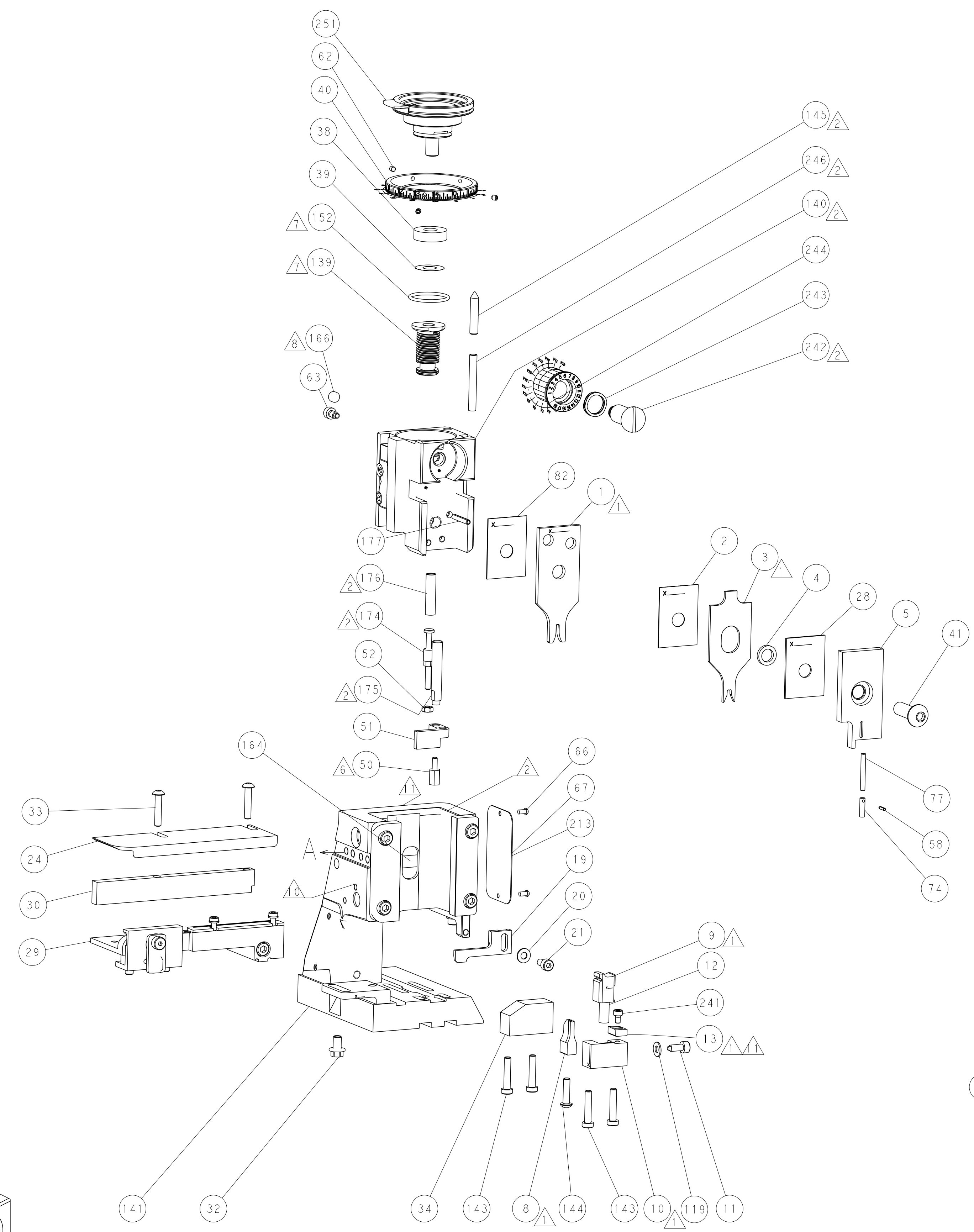
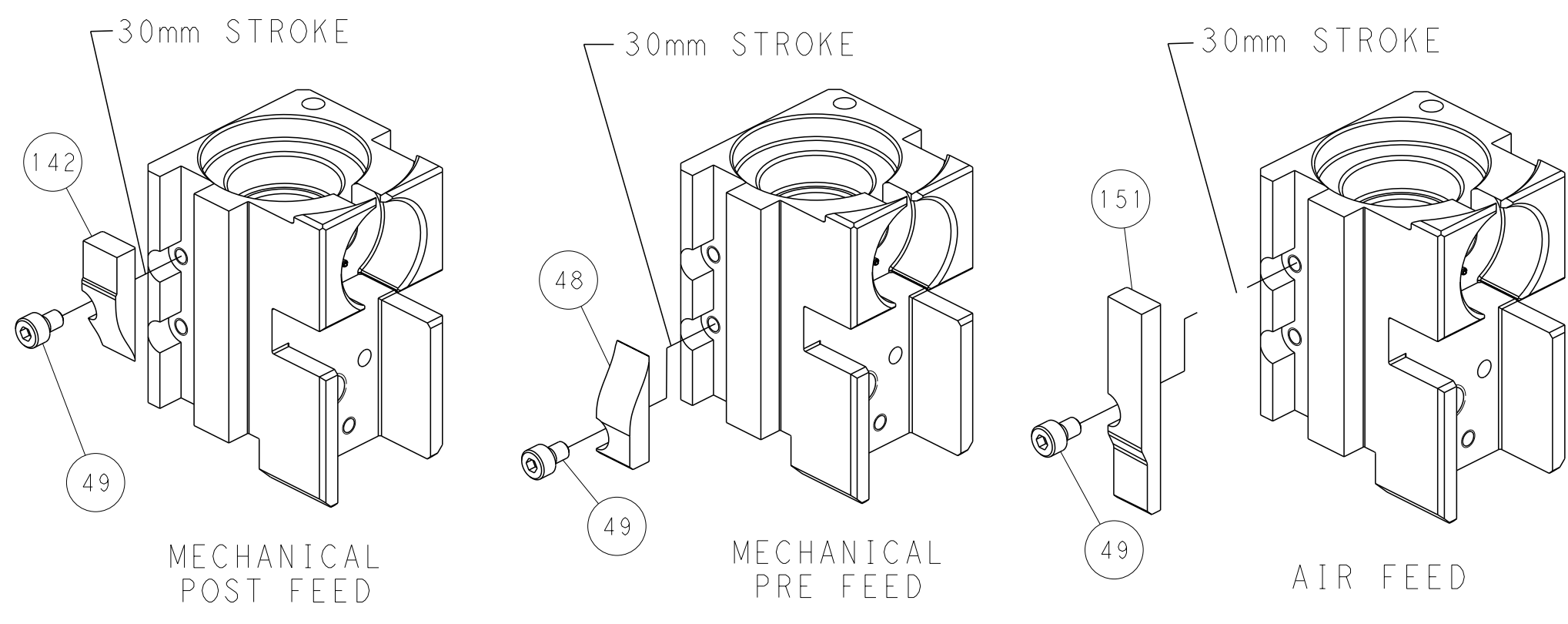

TERMINAL SUPPORT LOCATION

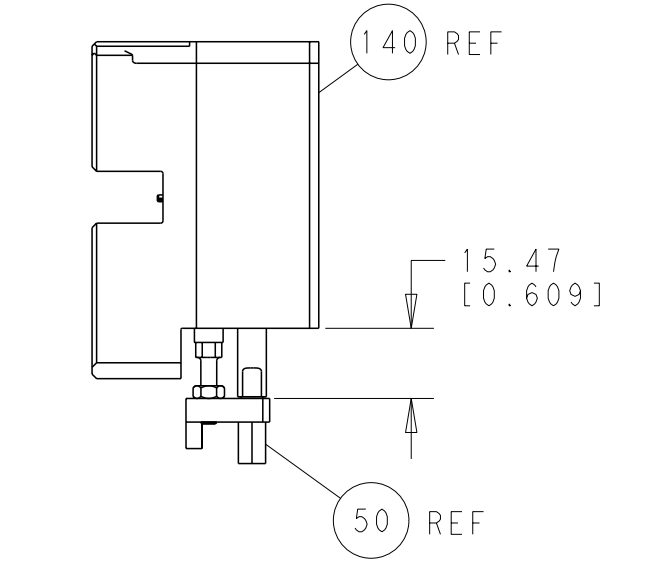

HOLDDOWN SET-UP

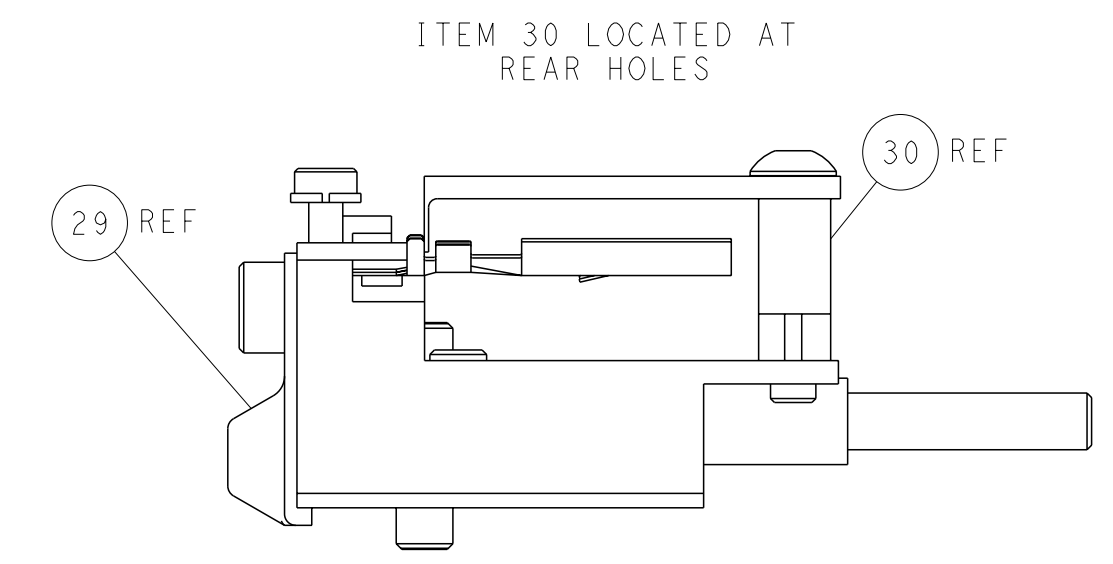

FEED TRACK POSITION GUIDE BY INSULATION BARREL

PACIFIC VERSION
 Shown on sheets 3 of 4 & 4 of 4
 (Atlantic version shown on sheets 1 of 4 & 2 of 4)

<small>THIS DRAWING IS UNPUBLISHED. RELEASED FOR PUBLICATION. COPYRIGHT 20 BY TYCO ELECTRONICS CORPORATION. ALL RIGHTS RESERVED.</small>		DWN: R. HUANG 28DEC2011 CHK: S. XI 28DEC2011 APVD: J. CRUZ 28DEC2011	TE Connectivity Harrisburg, PA 17105-3608
DIMENSIONS: mm 		TOLERANCES UNLESS OTHERWISE SPECIFIED: 9 PLC ±.5 1 PLC ±0.5 2 PLC ±0.13 3 PLC ±0.013 4 PLC ±0.001 ANGLES FINISH ±.	NAME: Ocean Side Feed Applicator PRODUCT SPEC: - APPLICATION SPEC: - SIZE: A CAGE CODE: 00779 DRAWING NO: C=2151548 RESTRICTED TO: -
MATERIAL: - FINISH: -		WEIGHT: - CUSTOMER ACCESSIBLE PRODUCTION DRAWING: -	SCALE: 1:2 SHEET: 4 OF 4 REV: A