

THIS DRAWING IS UNPUBLISHED. RELEASED FOR PUBLICATION 20
 © COPYRIGHT 20 BY - ALL RIGHTS RESERVED.

REVISIONS				
P	LTR	DESCRIPTION	DATE	APVD
A		PRODUCTION RELEASE	13JUN2019	JW SH

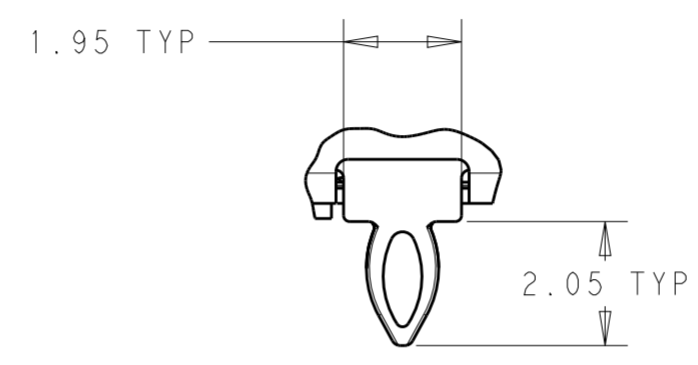
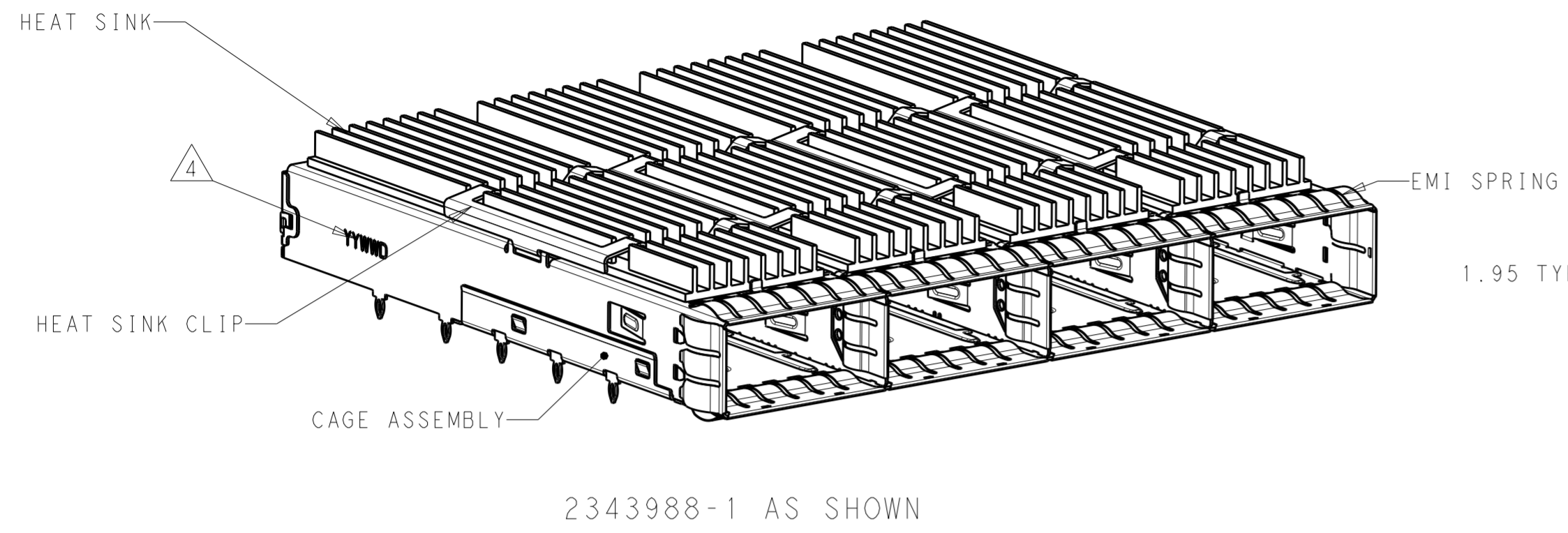

DETAIL A
SCALE 8:1

- 1 CAGE ASSEMBLY: STAINLESS STEEL.
HEAT SINK: ALUMINUM/BLACK ANODIZE.
HEAT SINK CLIP: STAINLESS STEEL.
EMI SPRING: COPPER ALLOY/NICKEL PLATE.
- 2 REFERENCE APPLICATION SPECIFICATION 114-32023 FOR RECOMMENDED DRILL HOLE DIAMETER AND PLATING THICKNESS. BOARD LAYOUT PER THIS PRINT.
- 3 DATUM AND BASIC DIMENSION ESTABLISHED BY CUSTOMER.
- 4 DATE CODE (YYWW) MARKED APPROXIMATELY AS SHOWN.
- 5. MATES WITH QSFP DD MSA COMPATIBLE TRANSCEIVER.
- 6. MINIMUM PC BOARD THICKNESS: SINGLE SIDED: 1.45 MIN
DOUBLE SIDED: 2.20 MIN
- 7 ONLY FOR VERSION WITH REAR EONS

2343988-1 AS SHOWN

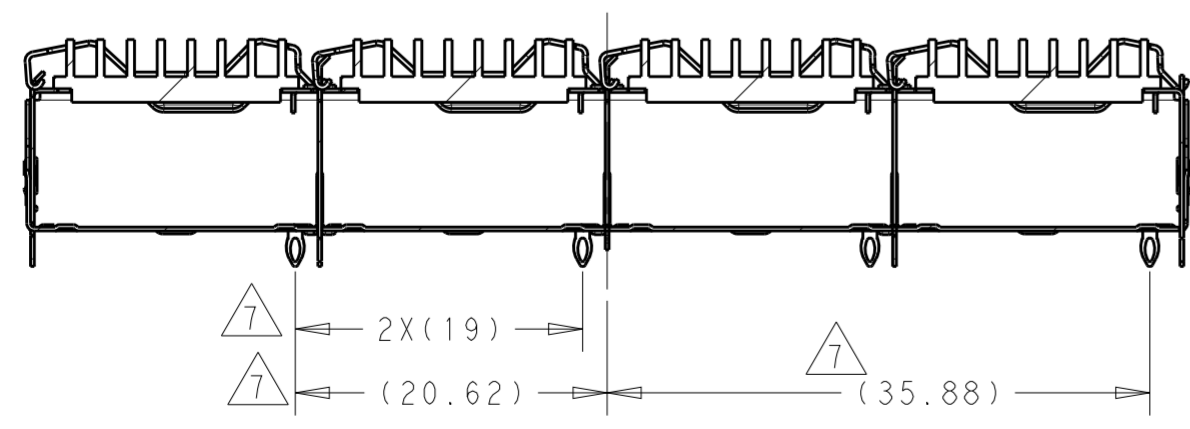
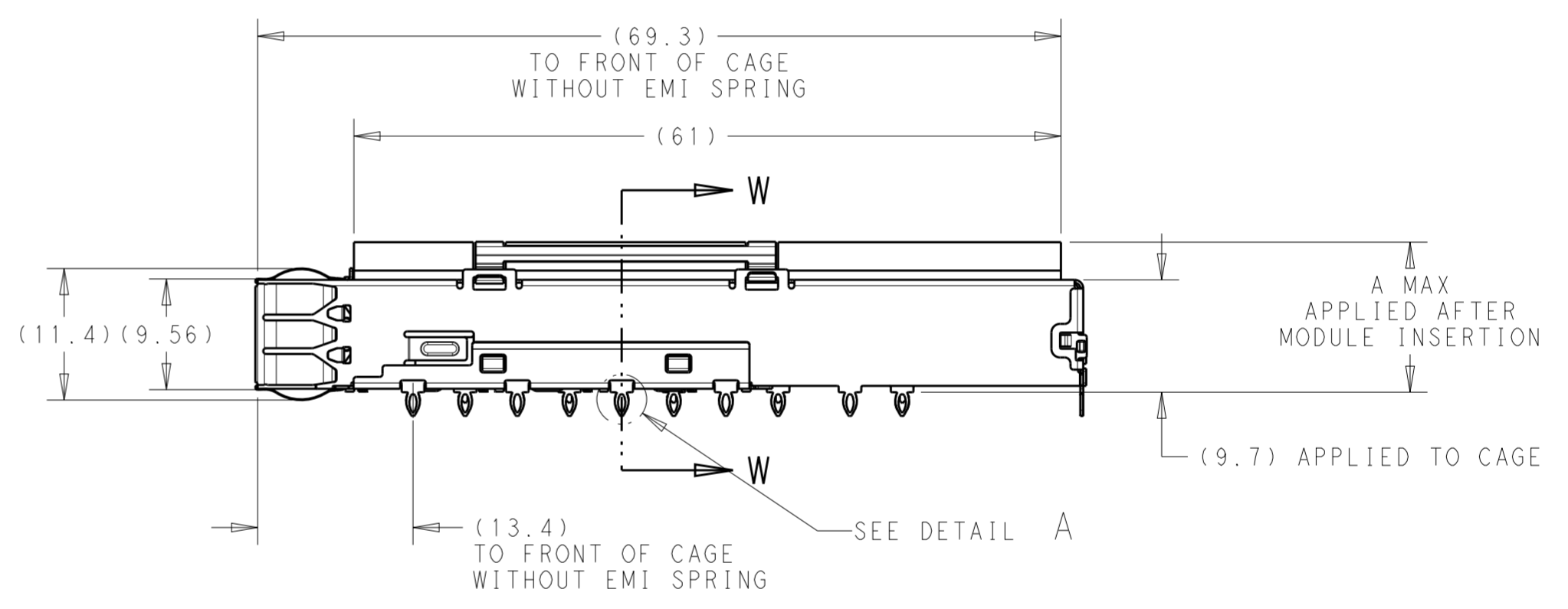
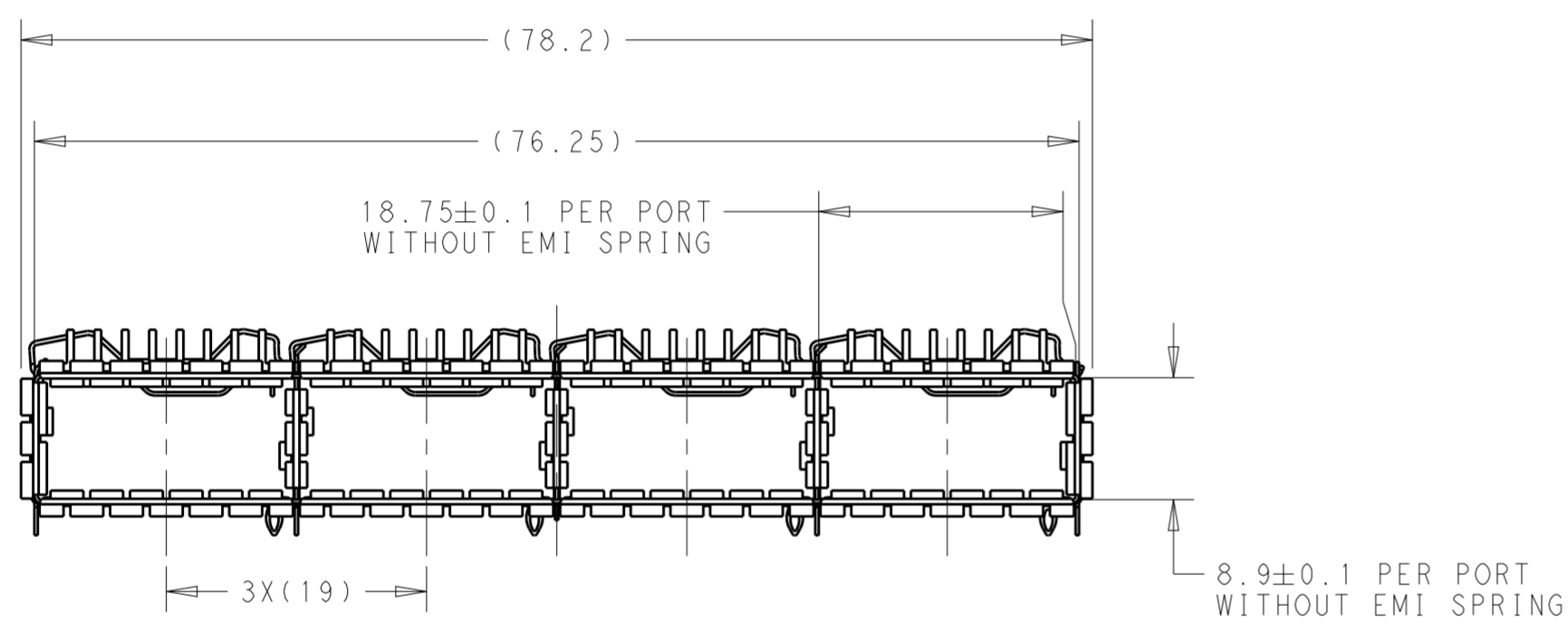

For 2343988-1/-2-3 WITH REAR EONS
SECTION W-W

W/O REAR EONS	23	1-2343988-3
W/O REAR EONS	16	1-2343988-2
W/O REAR EONS	13.7	1-2343988-1
W REAR EONS	23	2343988-3
W REAR EONS	16	2343988-2
W REAR EONS	13.7	2343988-1
VERSION	DIM A	PART NUMBER

THIS DRAWING IS A CONTROLLED DOCUMENT.		DWN J. WANG 10OCT2018	TE Connectivity	
DIMENSIONS: mm		CHK S. HAN 10OCT2018		
TOLERANCES UNLESS OTHERWISE SPECIFIED:		APVD S. HAN 10OCT2018	NAME CAGE WITH HEATSINK THRU BEZEL, 1X4, QSFP DD	
0 PLC ±0.25	1 PLC ±0.25	PRODUCT SPEC -	SIZE A2	
2 PLC ±0.25	3 PLC ±	APPLICATION SPEC -	CAGE CODE -	DRAWING NO C-2343988
4 PLC ±	ANGLES ±	WEIGHT -	RESTRICTED TO -	SCALE 1:1
FINISH -1	FINISH -1	CUSTOMER DRAWING	SHEET 1 OF 6	REV A

THIS DRAWING IS UNPUBLISHED. RELEASED FOR PUBLICATION 20
 © COPYRIGHT 20 BY - ALL RIGHTS RESERVED.

REVISIONS					
P	LTR	DESCRIPTION	DATE	DWN	APVD
-		SEE SHEET 1	-	-	-

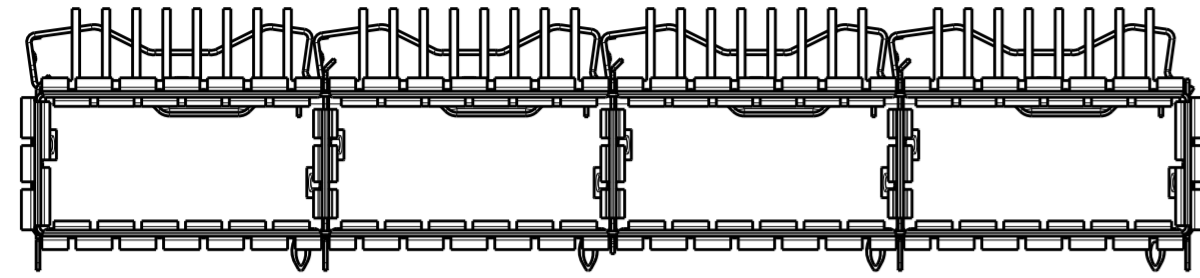

2343988-2
 UNMARKED DIMENSIONS SAME AS 2343988-1
 SCALE 2:1

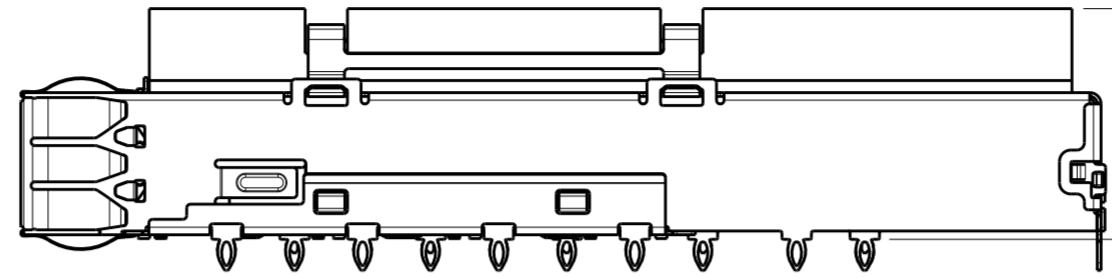

A MAX
 AFTER MODULE
 INSERTION

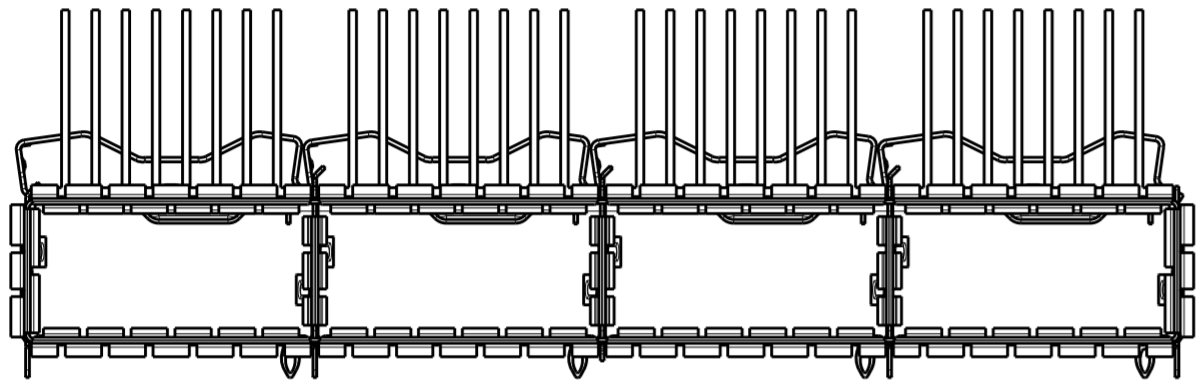
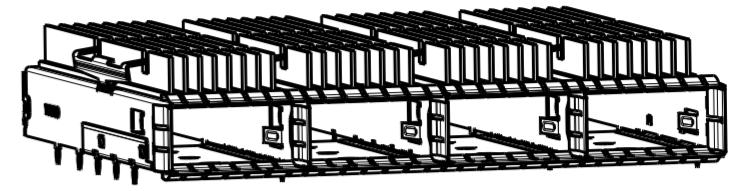

2343988-3
 UNMARKED DIMENSIONS SAME AS 2343988-1
 SCALE 2:1

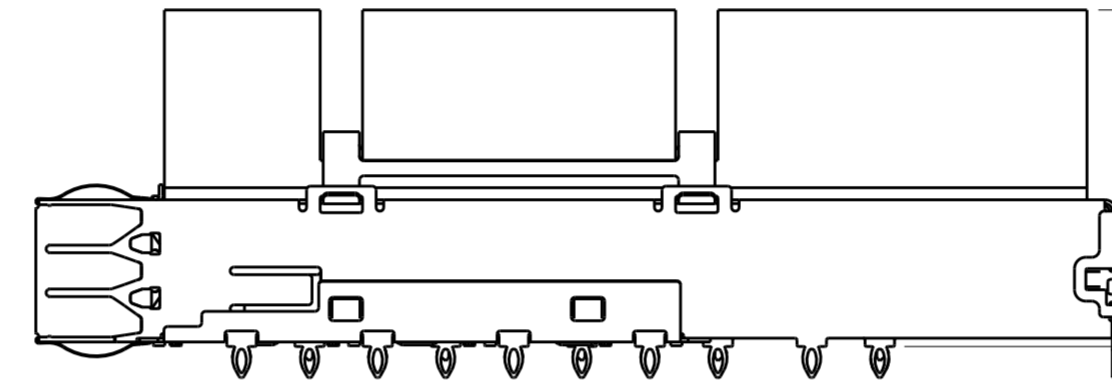

AMAX
 AFTER MODULE
 INSERTION

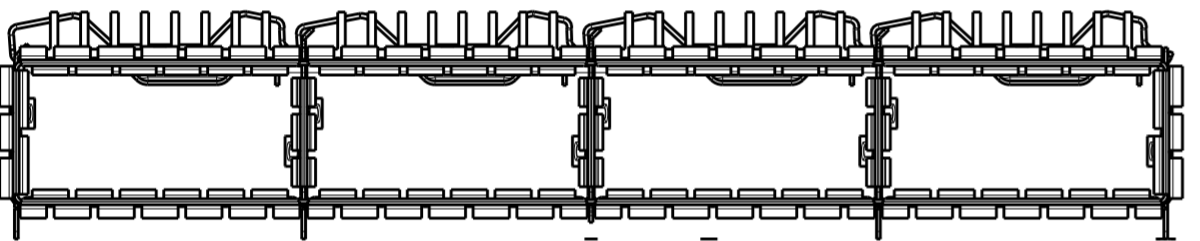
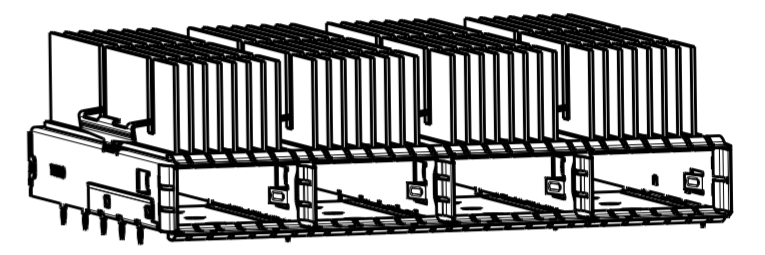

1-2343988-1
 WITHOUT REAR EONS
 UNMARKED DIMENSIONS SAME AS 2343988-1
 SCALE 2:1

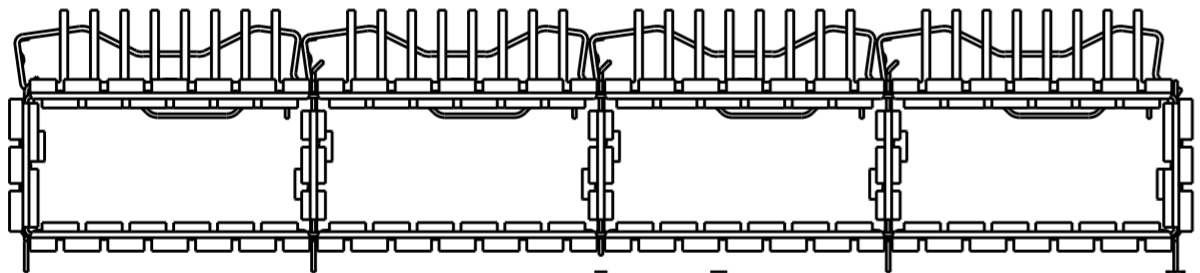
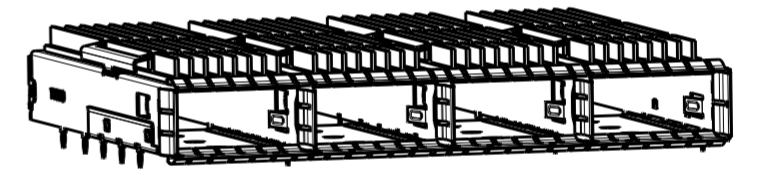
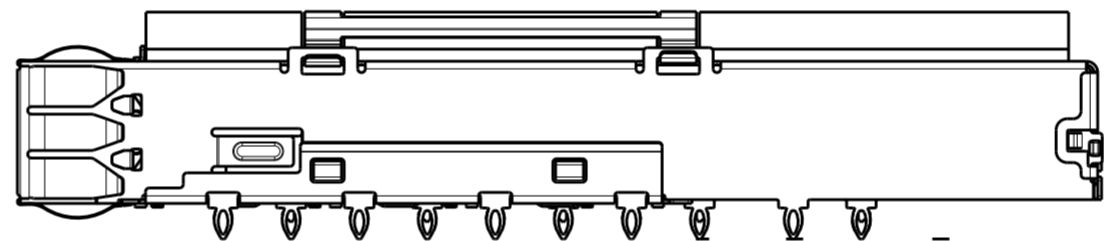

1-2343988-2
 WITHOUT REAR EONS
 UNMARKED DIMENSIONS SAME AS 2343988-2
 SCALE 2:1

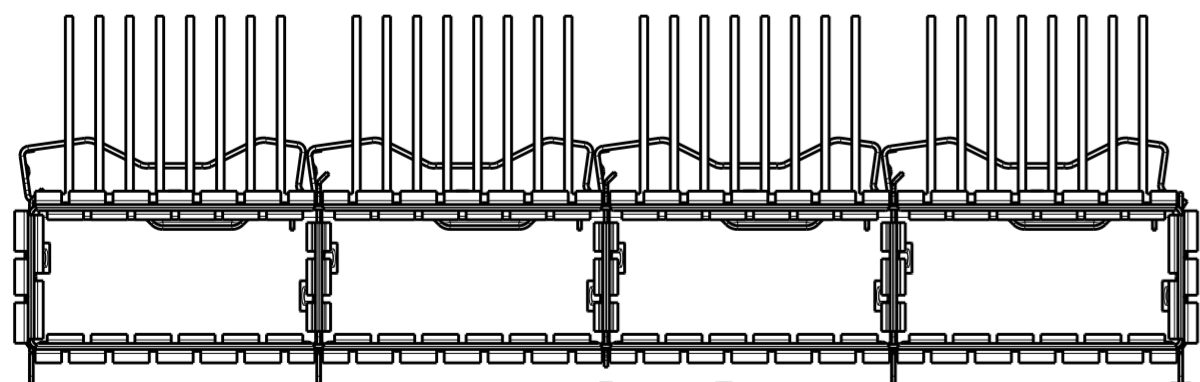
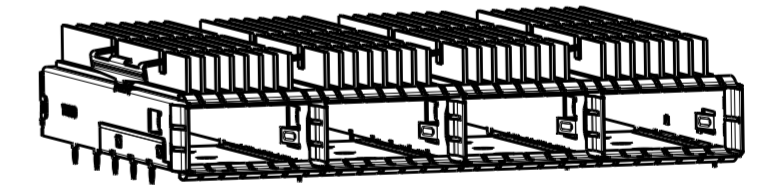
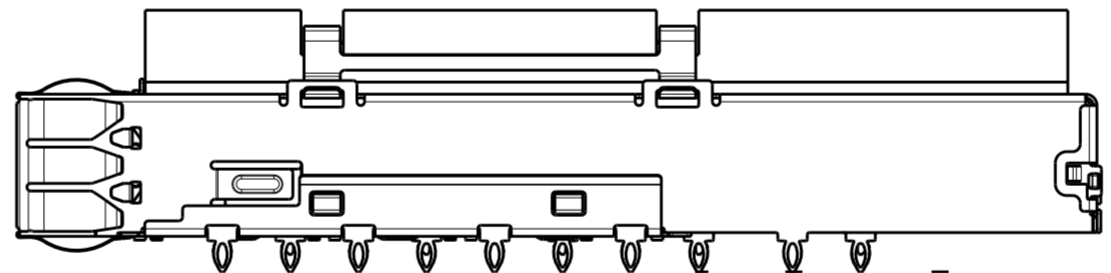

1-2343988-3
 WITHOUT REAR EONS
 UNMARKED DIMENSIONS SAME AS 2343988-3
 SCALE 2:1

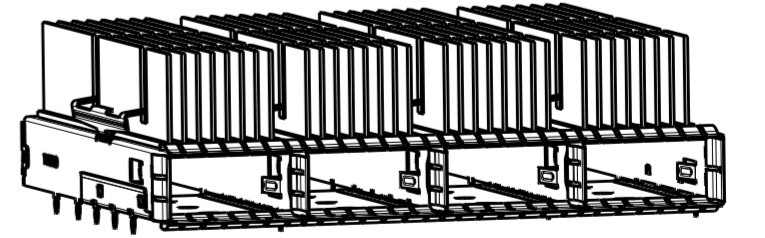
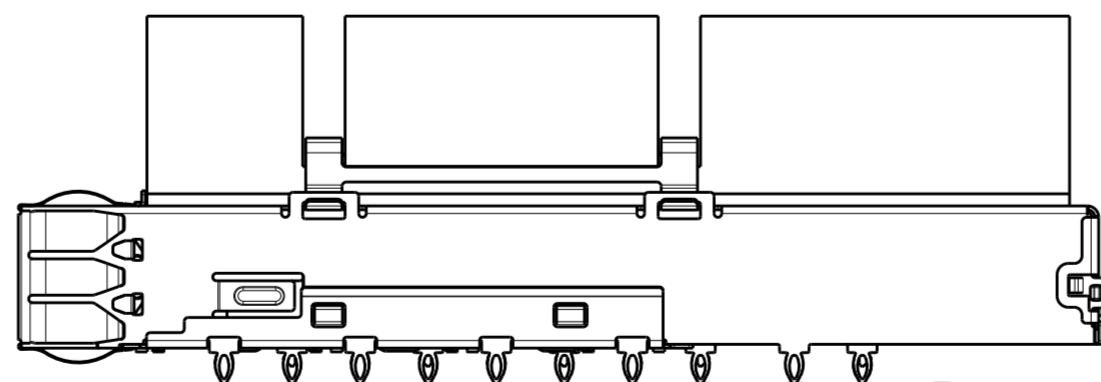

THIS DRAWING IS A CONTROLLED DOCUMENT.		DWN J. WANG 10OCT2018	TE Connectivity	
DIMENSIONS:		CHK S. HAN 10OCT2018		
mm	TOLERANCES UNLESS OTHERWISE SPECIFIED:	APVD S. HAN 10OCT2018	NAME CAGE WITH HEATSINK THRU BEZEL, 1X4, QSFP DD	
	0 PLC ±0.25 1 PLC ±0.25 2 PLC ±0.25 3 PLC ± 4 PLC ± ANGLES ± FINISH	PRODUCT SPEC -	RESTRICTED TO	
MATERIAL	-	APPLICATION SPEC -	SIZE A2	CAGE CODE -
		WEIGHT -	DRAWING NO G-2343988	SCALE 1:1
		CUSTOMER DRAWING	SHEET 2 OF 6	REV A

THIS DRAWING IS UNPUBLISHED. RELEASED FOR PUBLICATION 20
 © COPYRIGHT 20 BY - ALL RIGHTS RESERVED.

REVISIONS				
P	LTR	DESCRIPTION	DATE	APVD
-	-	SEE SHEET 1	-	-

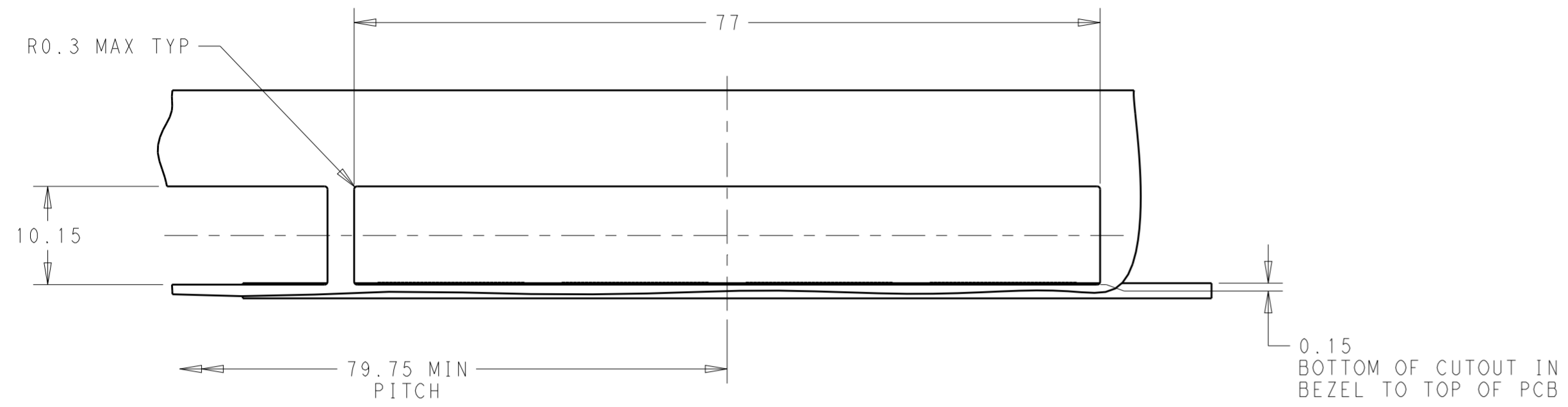

CAGE ASSEMBLY OMITTED FOR CLARITY

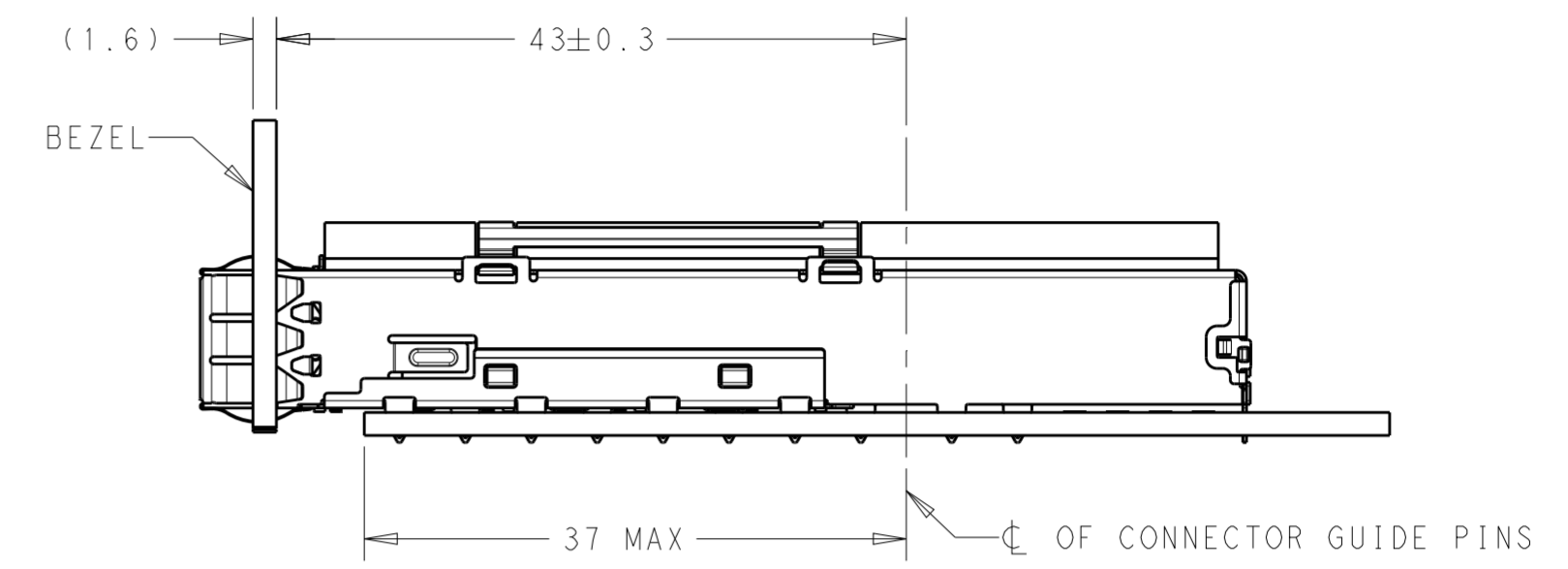

SINGLE SIDE MOUNTING

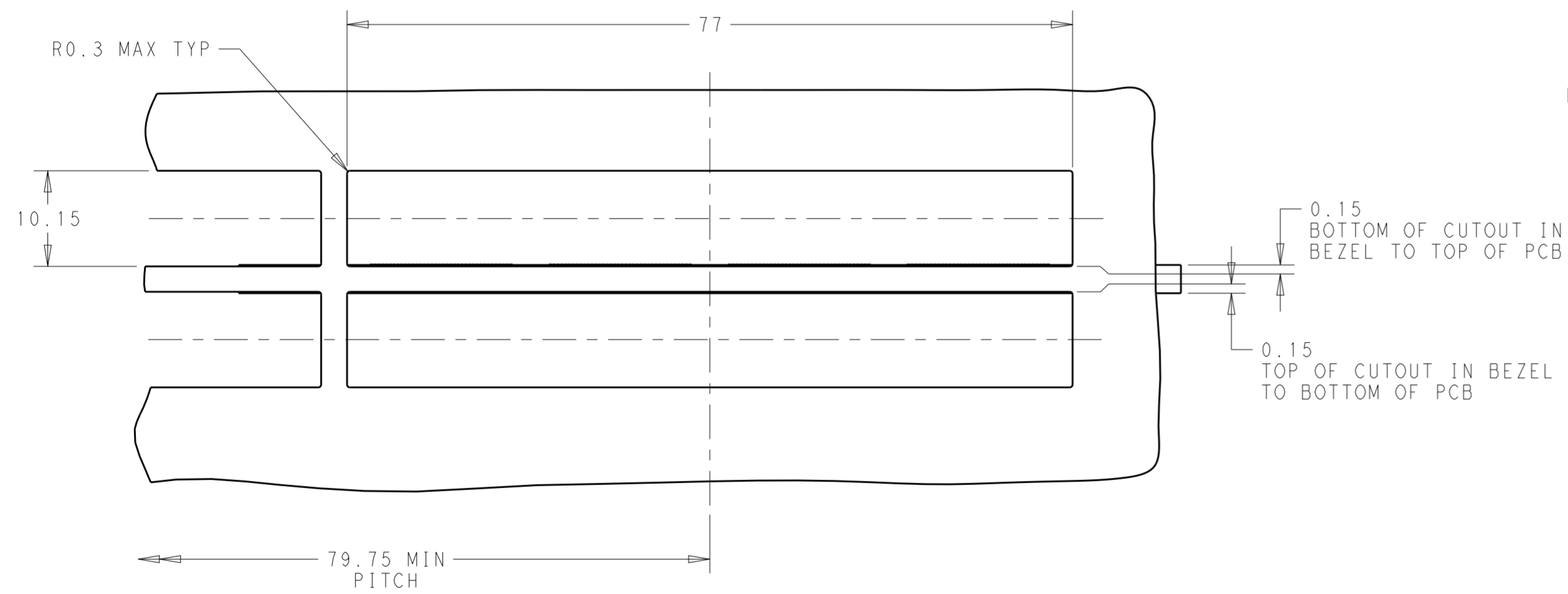

CAGE ASSEMBLY OMITTED FOR CLARITY

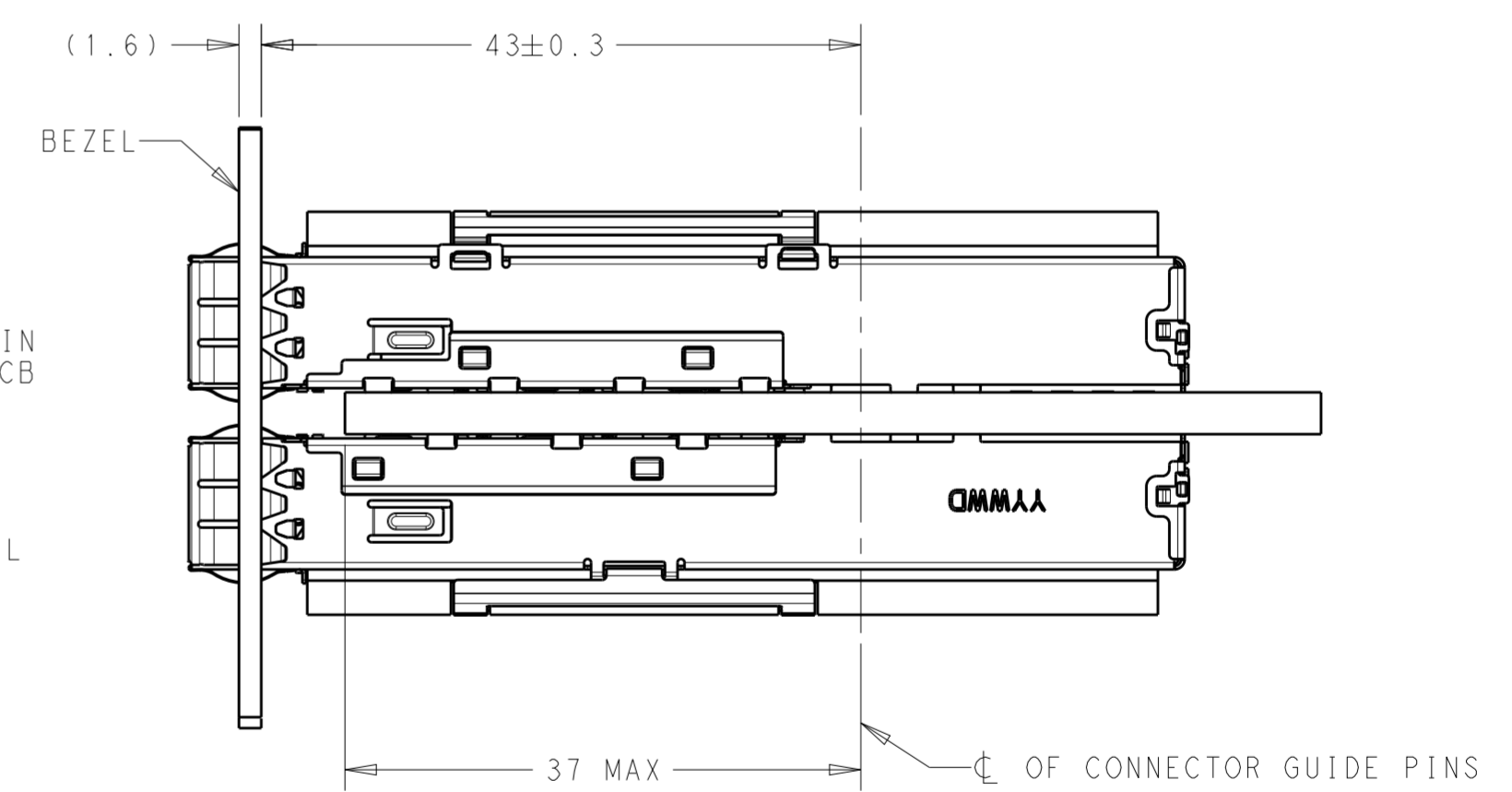

BELLY TO BELLY MOUNTING

THIS DRAWING IS A CONTROLLED DOCUMENT.		DWN J. WANG 10OCT2018	TE Connectivity	
DIMENSIONS: mm		CHK S. HAN 10OCT2018		
TOLERANCES UNLESS OTHERWISE SPECIFIED:		APVD S. HAN 10OCT2018	NAME CAGE WITH HEATSINK THRU BEZEL, 1X4, QSFP DD	
0 PLC ±0.25 1 PLC ±0.25 2 PLC ±0.25 3 PLC ± 4 PLC ± ANGLES ± FINISH ±		PRODUCT SPEC -	RESTRICTED TO -	
MATERIAL -		APPLICATION SPEC -	SIZE A2	CAGE CODE -
		WEIGHT -	DRAWING NO C-2343988	
		CUSTOMER DRAWING	SCALE 1:1	SHEET 3 OF 6
			REV A	

THIS DRAWING IS UNPUBLISHED. RELEASED FOR PUBLICATION 20
 © COPYRIGHT 20 BY - ALL RIGHTS RESERVED.

REVISIONS				
P	LTR	DESCRIPTION	DATE	APVD
-	-	SEE SHEET 1	-	-

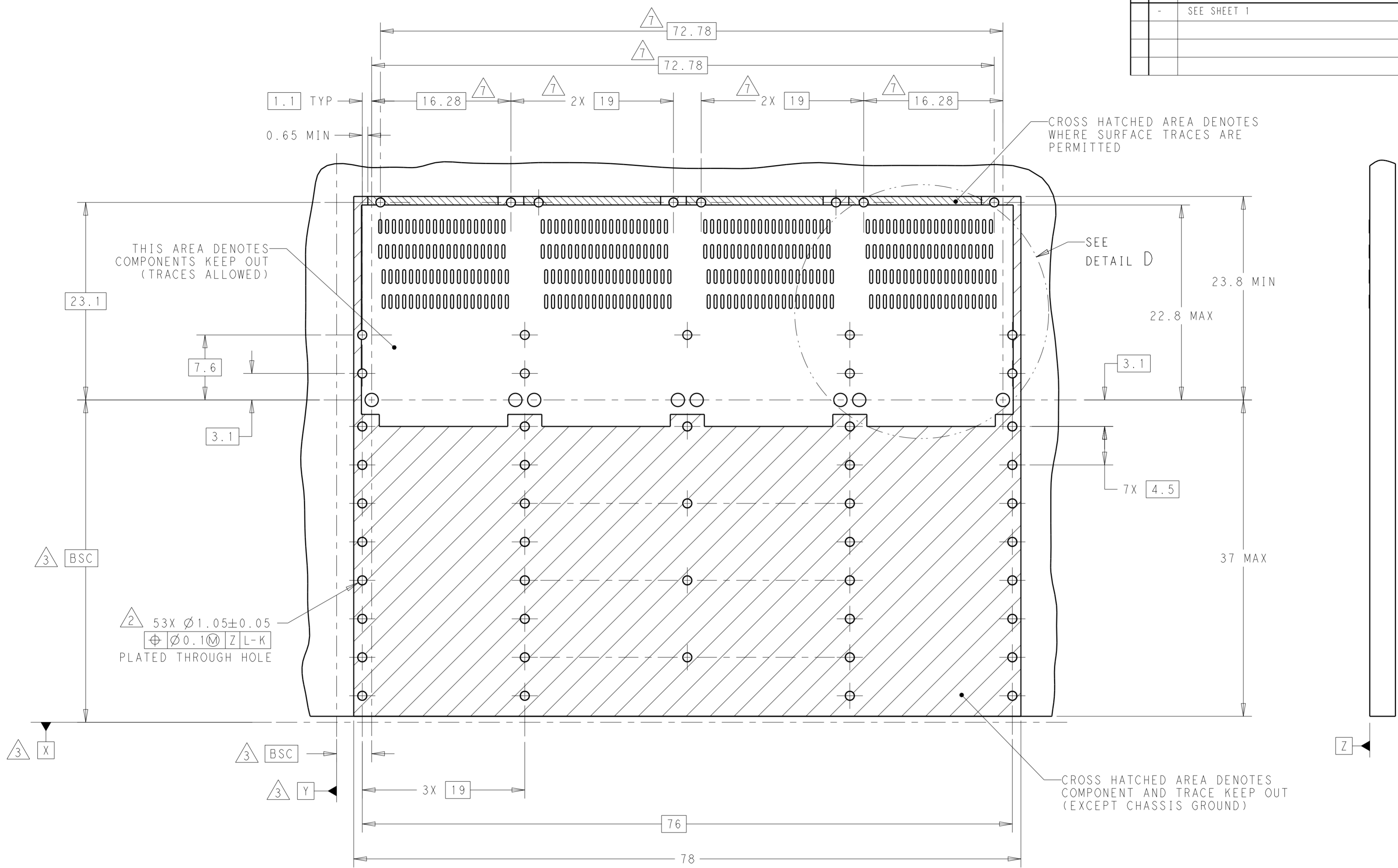

THIS AREA DENOTES COMPONENTS KEEP OUT (TRACES ALLOWED)

CROSS HATCHED AREA DENOTES WHERE SURFACE TRACES ARE PERMITTED

SEE DETAIL D

CROSS HATCHED AREA DENOTES COMPONENT AND TRACE KEEP OUT (EXCEPT CHASSIS GROUND)

2 53X $\varnothing 1.05 \pm 0.05$
 $\varnothing 0.1$ Z L-K
 PLATED THROUGH HOLE

RECOMMENDED PCB LAYOUT
 BELLY TO BELLY
 SCALE 3:1

THIS DRAWING IS A CONTROLLED DOCUMENT.		DWN J. WANG 10OCT2018	TE Connectivity	
DIMENSIONS: mm		CHK S. HAN 10OCT2018		
TOLERANCES UNLESS OTHERWISE SPECIFIED:		APVD S. HAN 10OCT2018	NAME CAGE WITH HEATSINK THRU BEZEL, 1X4, QSFP DD	
0 PLC ± 0.25		PRODUCT SPEC	SIZE	
1 PLC ± 0.25		APPLICATION SPEC	CAGE CODE	
2 PLC ± 0.25		WEIGHT	DRAWING NO	
3 PLC \pm		CUSTOMER DRAWING	RESTRICTED TO	
4 PLC \pm		SCALE 2:1	SHEET 5 OF 6	
ANGLES \pm		REV A		
FINISH				

THIS DRAWING IS UNPUBLISHED. RELEASED FOR PUBLICATION 20
 © COPYRIGHT 20 BY - ALL RIGHTS RESERVED.

REVISIONS				
P	LTR	DESCRIPTION	DATE	APVD
-	-	SEE SHEET 1	-	-

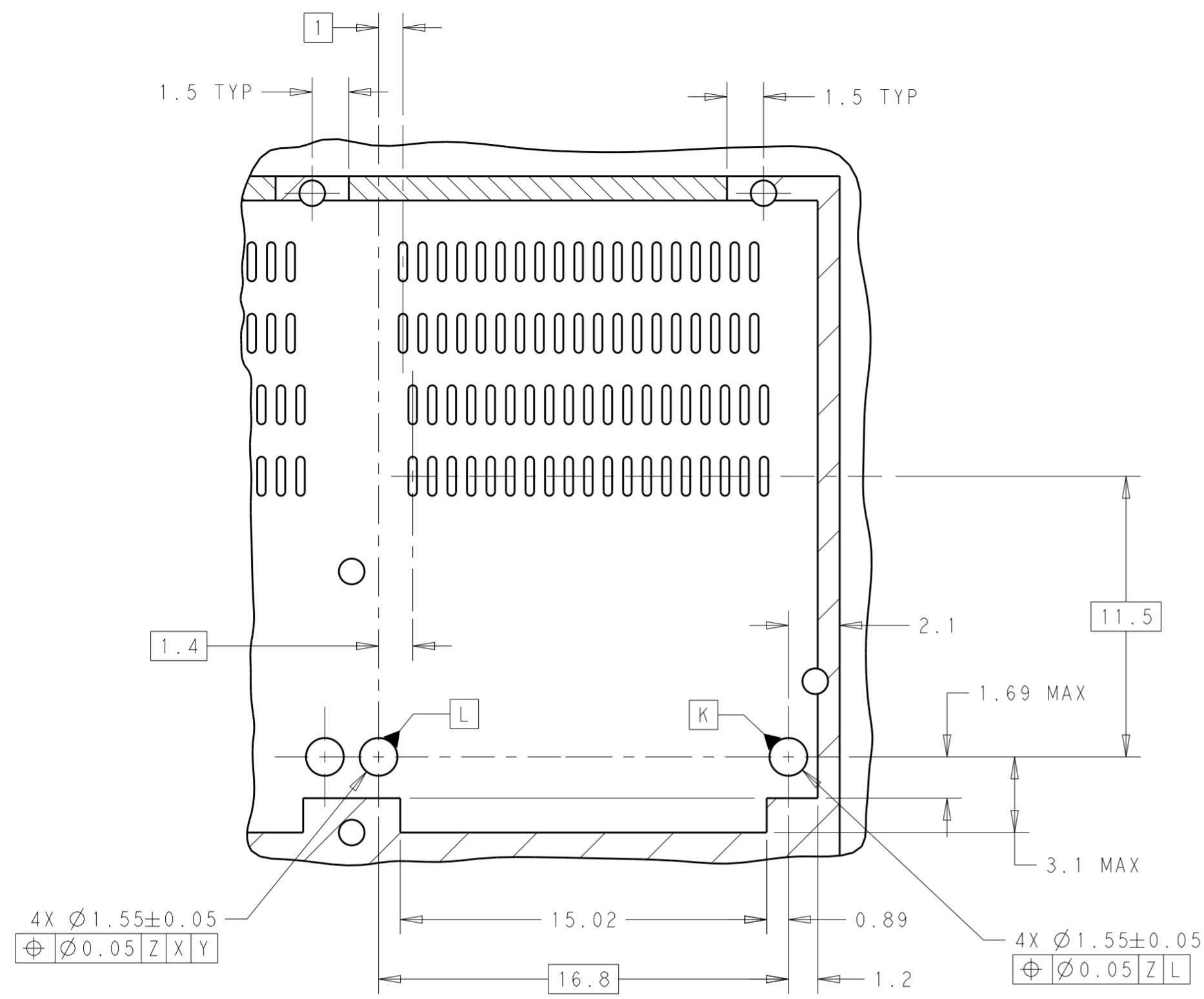

DETAIL B
SCALE 5:1

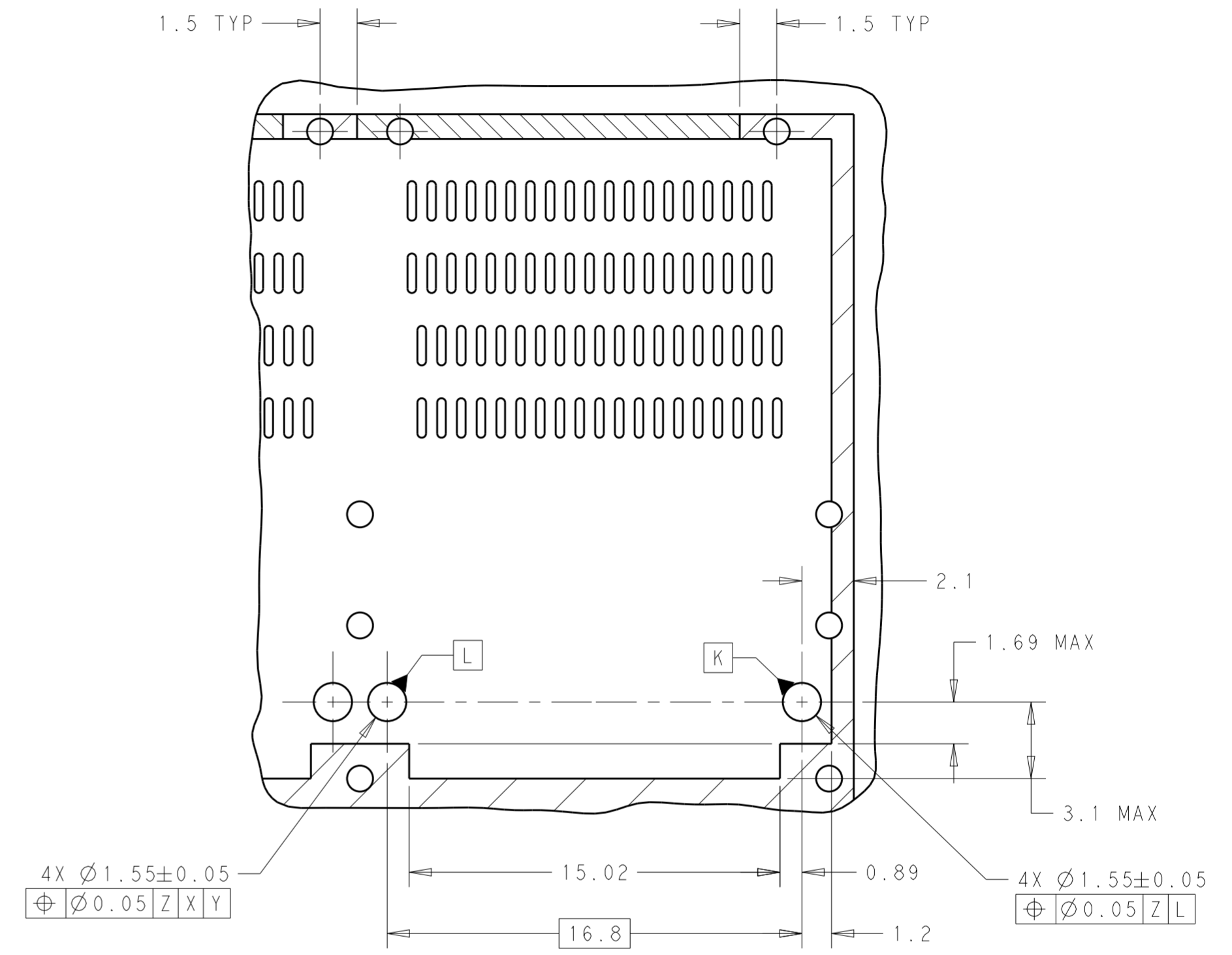

DETAIL D
SCALE 5:1

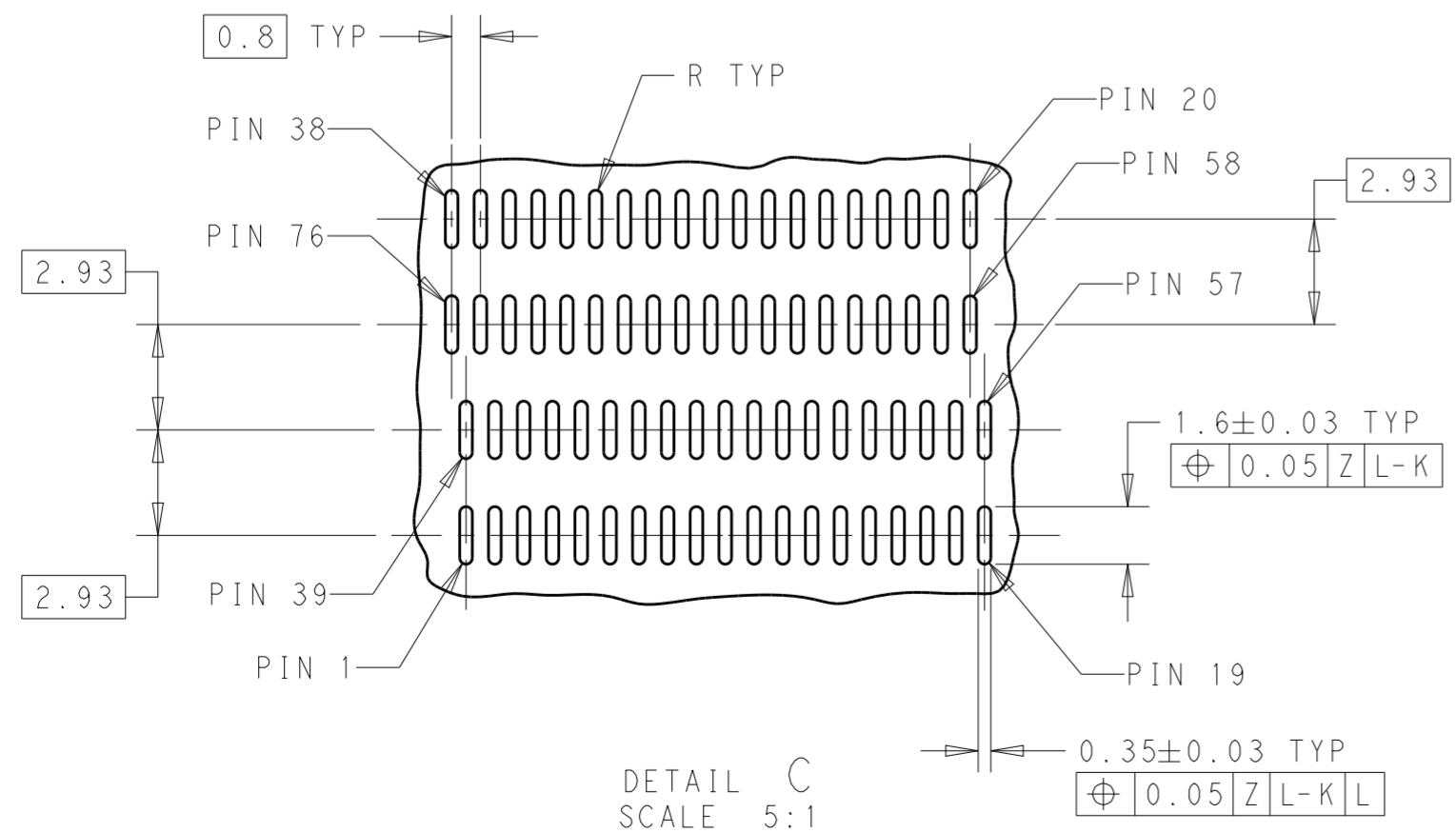

DETAIL C
SCALE 5:1

THIS DRAWING IS A CONTROLLED DOCUMENT.		DWN J. WANG 10OCT2018	 TE Connectivity
DIMENSIONS: mm		CHK S. HAN 10OCT2018	
TOLERANCES UNLESS OTHERWISE SPECIFIED:		APVD S. HAN 10OCT2018	
0 PLC ±0.25 1 PLC ±0.25 2 PLC ±0.25 3 PLC ± 4 PLC ± ANGLES ± FINISH ±		NAME CAGE WITH HEATSINK THRU BEZEL, 1X4, QSFP DD SIZE A2 CAGE CODE - DRAWING NO C-2343988 RESTRICTED TO -	
MATERIAL	-	PRODUCT SPEC	-
		APPLICATION SPEC	-
		WEIGHT	-
CUSTOMER DRAWING		SCALE	2:1
		SHEET	6 OF 6
		REV	A