

P	LTR	DESCRIPTION	DATE	DWN	APVD
B2		REVISED PER ECO-12-007714	28APR2012	KH	MS
C		DESIGN IMPROVEMENT IN NEW MOLD	21JUL2020	DV	PS
D		REVISED AS PER PCN: E-20-012263	10NOV2021	SCB	SS

- 1 MATERIALS AND FINISH
HOUSING: HIGH TEMPERATURE POLYAMIDE, UL 94V-0 RATED, COLOR GREEN.
TERMINAL: COPPER ALLOY, TIN PLATED.
- 2 SUITABLE FOR 1,6-2,4mm PC BOARD THICKNESS.
- 3 ELECTRICAL
RATED VOLTAGE : 300 V
RATED CURRENT : 12 A
CONTACT RESISTANCE : < 15 mΩ
INSULATION RESISTANCE: > 1000 MΩ (500V DC)
- 4 OPERATING TEMPERATURE RANGE: -40°C TO +110°C
- 5 P/N FROM 284061-4 TO 2-284061-6 ARE OBTAINED BY ASSEMBLING 284061-2 AND 284061-3 TO ACHIEVE THE DESIRED NUMBER OF POSITIONS.

- 6 PARTS HAS BEEN DISCONTINUED
- 7 NON CUMULATIVE TOLERANCE

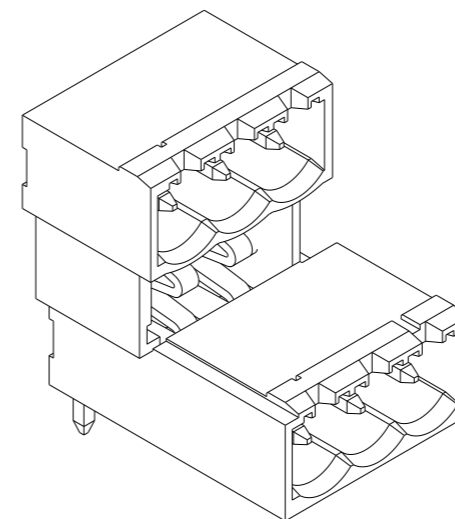
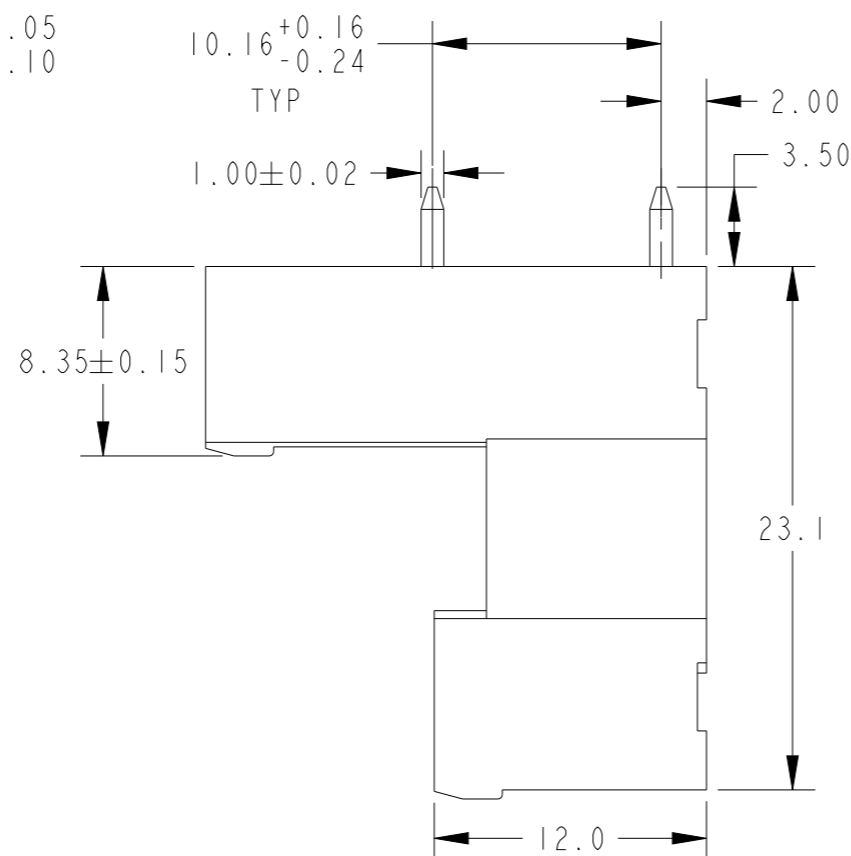
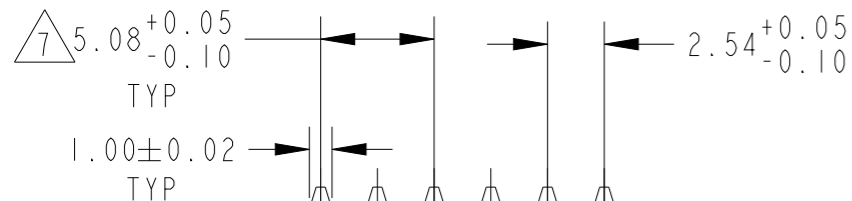
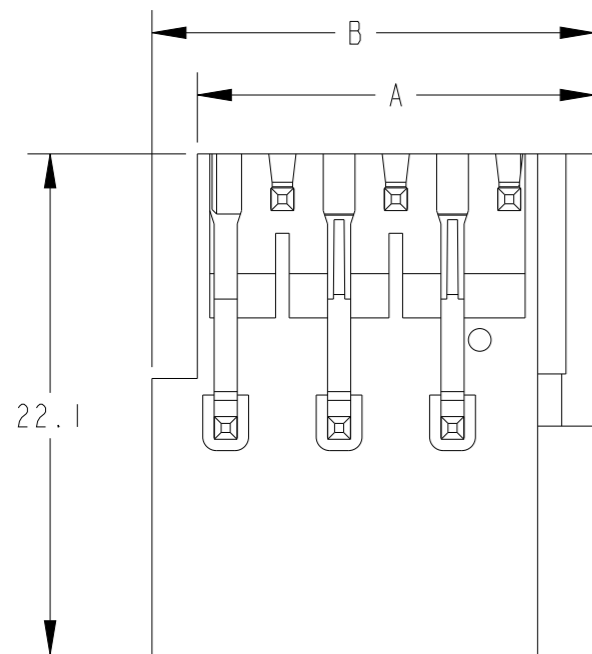

284061-3 AS SHOWN

A	B	NO OF POS	PART NUMBER
83.08	85.58	16	2-284061-6
128.80	131.30	25	2-284061-5
123.68	126.18	24	2-284061-4
118.44	121.14	23	2-284061-3
113.56	116.06	22	2-284061-2
108.44	110.94	21	2-284061-1
103.40	105.90	20	2-284061-0
98.32	100.82	19	1-284061-9
93.20	95.70	18	1-284061-8
88.16	90.66	17	1-284061-7
83.08	85.58	16	1-284061-6
77.96	80.46	15	1-284061-5
72.92	75.45	14	1-284061-4
67.84	70.34	13	1-284061-3
62.72	65.22	12	1-284061-2
57.68	60.18	11	1-284061-1
52.60	55.10	10	1-284061-0
47.48	49.98	9	284061-9
42.44	44.94	8	284061-8
37.36	39.86	7	284061-7
32.24	34.74	6	284061-6
27.20	29.70	5	284061-5
22.16	24.66	4	284061-4
17.00	19.50	3	284061-3
12.00	14.50	2	284061-2

RECOMMENDED PC BOARD LAYOUT

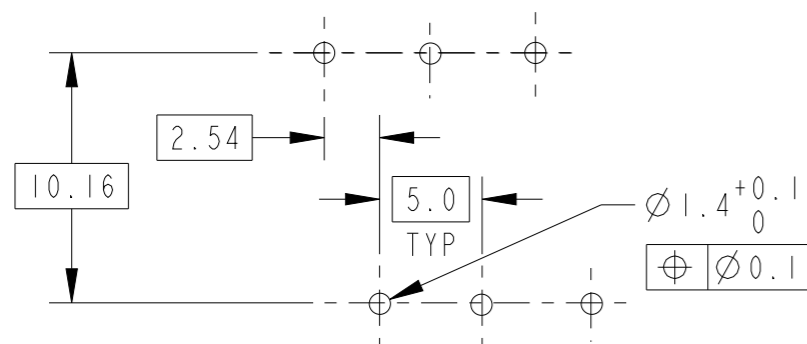

THIS DRAWING IS A CONTROLLED DOCUMENT.		DWN E. ZANOLINI 24JAN2002	TE Connectivity	
DIMENSIONS: mm		CHK E. ZANOLINI 24JAN2002		
TOLERANCES UNLESS OTHERWISE SPECIFIED:		APVD D. BIEVENOUR 24JAN2002	NAME TERMINAL BLOCK MULTIPLE HEADER, 90 DEGREE CLOSED ENDS 5.08mm PITCH	
0 PLC ±- 1 PLC ±.3 2 PLC ±.25 3 PLC ±- 4 PLC ±- ANGLES ±2°		PRODUCT SPEC -	APPLICATION SPEC 114-20079	
MATERIAL		WEIGHT -	SIZE A3	CAGE CODE 00779
FINISH		CUSTOMER DRAWING	DRAWING NO C-284061	RESTRICTED TO
		SCALE 3:1	SHEET 1 OF 1	REV D