

THIS DRAWING IS UNPUBLISHED  
 RELEASED FOR PUBLICATION 2017  
 © COPYRIGHT 2017 BY - TE CONNECTIVITY ALL RIGHTS RESERVED.

REVISIONS					
P	LTR	DESCRIPTION	DATE	DWN	APVD
	F	REVISED PER PCN E-17-009091	13MAY2017	CM	DM

SEAL TYPE	CONTACT SIZE	MIN. INSUL. OD [mm]	MAX. INSUL. OD [mm]	WIRE RANGE [mm <sup>2</sup> ] REF ONLY
3	16	.100 [2.540]	.134 [3.404]	14-18 AWG [2.0-.75]
E	16	.053 [1.346]	.120 [3.048]	14-20 AWG [2.0-.50]

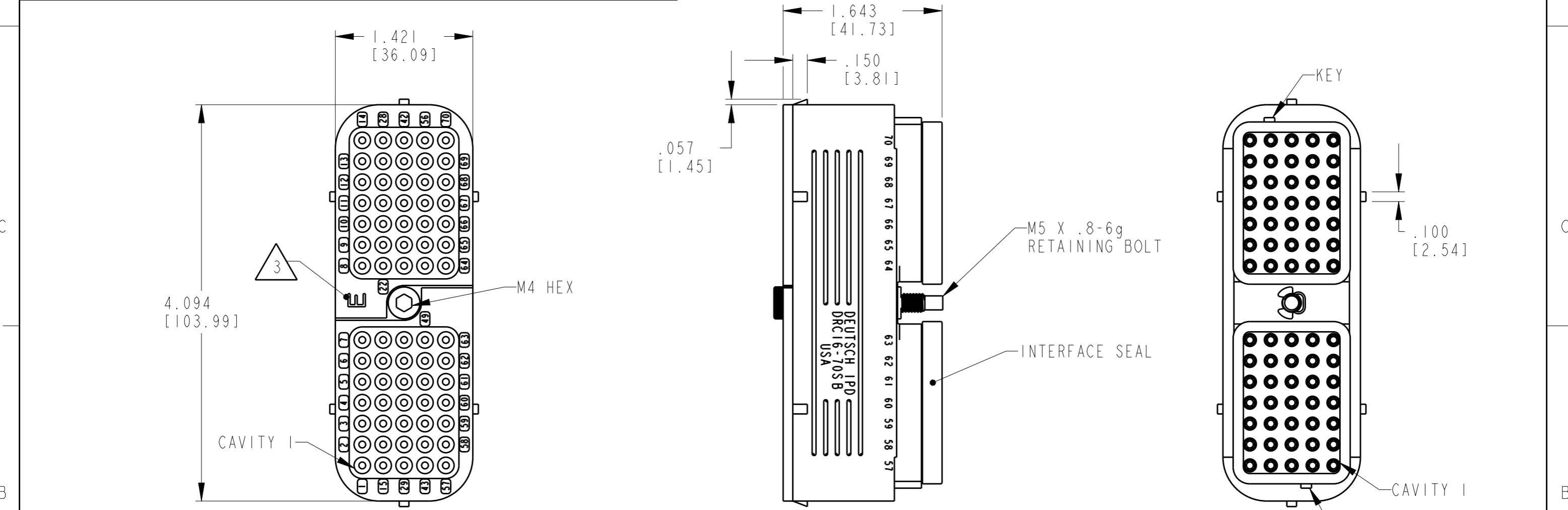

5. MATERIAL:  
 PLUG: PPS GF40 (BLACK)  
 SEAL/GROMMET: VMO (RED-ORANGE)  
 BOLT/CLIP: STAINLESS STEEL.

4. MATING TORQUE REQUIREMENT: 25-28 IN-LB [2.82-3.16 Nm].

3. WHEN X = E: LETTER "E" IDENTIFIES "E" WIRE SEAL.  
 WHEN X = BLANK: IDENTIFIES "NORMAL" WIRE SEAL (NOT SHOWN).

2. THIS PLUG MATES WITH DRC12-70PBX-XXXX; DRC13-70PB-XXXX;  
 DRC14-70PBX-XXXX.  
 (XXXX= ALL MODIFICATIONS) CONSULT FACTORY FOR MODS.

1. PLUG IS SUPPLIED WITH DUST CAP (NOT SHOWN).

NOTES:

TE INTERNAL PN	DEUTSCH PN
DRC16-70SB	DRC16-70SB
DRC16-70SBE	DRC16-70SBE

THIS DRAWING IS A CONTROLLED DOCUMENT.		DWN D. MEYER 15MAR1999		
DIMENSIONS: INCHES [mm]		CHK B. BYFORD 15APR2002		
TOLERANCES UNLESS OTHERWISE SPECIFIED:		APVD R. REED 15APR2002	NAME PLUG CONNECTOR DRC 70 SERIES KEY ARRANGEMENT -B-	
0 PLC ±		PRODUCT SPEC 0425-015-0000	SIZE A3	
1 PLC ±		APPLICATION SPEC 0425-015-0000	CAGE CODE 4AFU8	DRAWING NO. DRC16-70SBX
2 PLC ±		WEIGHT 154.1 g	RESTRICTED TO -	
3 PLC ±.025 [0.64]		CUSTOMER DRAWING	SCALE 1:1	SHEET 1 OF 1
4 PLC ±				REV F
ANGLES ±0° 30' 0"				
FINISH -				