

REV.	DATE	DESCRIPTION
A	08/19/98	MODIFY CONTACT PIN PLATING
B	05/01/04	UPDATE DRAWING FORMAT
C	12/17/07	REVISE BODY LENGTH AND MOUNTING HOLES

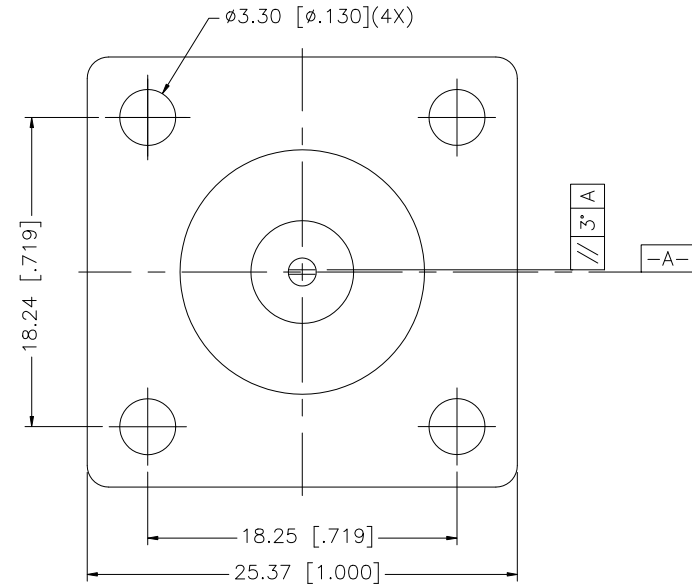
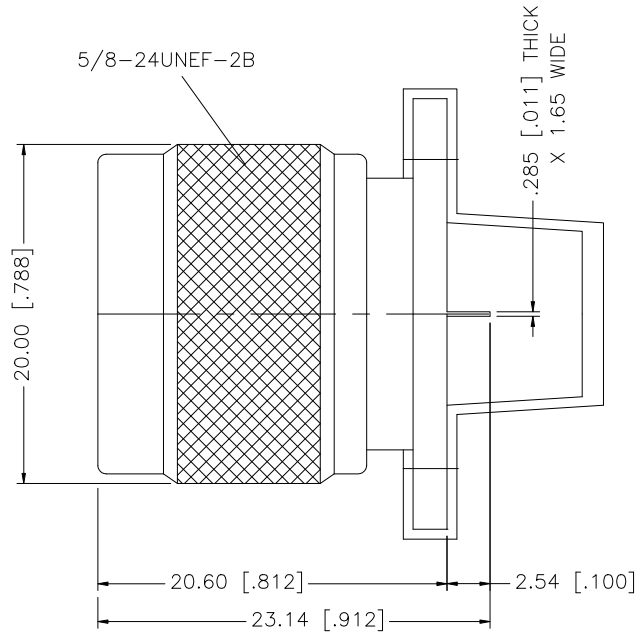

8				
7				
6				
5				
4				
3	INSULATOR	TEFLON	NATURAL	1
2	CONTACT BODY	BRASS	NEXCOTE	1
1	BODY WITH PANEL	BRASS	NEXCOTE	1
	DESCRIPTION	MATERIAL	FINISH	QTY

UNLESS OTHERWISE SPECIFIED DIMENSIONS ARE IN MILLIMETERS. DIMENSIONS IN [] ARE IN INCHES AND FOR CUSTOMER REFERENCE ONLY.

UNLESS OTHERWISE SPECIFIED TOLERANCES FOR MILLIMETERS ARE:
0.5 - 8mm ± 0.20mm
8 - 30mm ± 0.40mm
30 - 120mm ± 0.50mm

UNLESS OTHERWISE SPECIFIED TOLERANCES FOR INCHES ARE:
.020 - .315 = ± 0.007"
.315 - 1.180 = ± 0.015"
1.180 - 4.724 = ± 0.020"

DO NOT SCALE DRAWING

APPROVALS	DATE
DRAWN G.R.S.	12/17/07
CHECKED	
ISSUED	
SHEET 1 OF 1	
CAD FILE	C:/172/172196.DWG

Amphenol Connex

PART DESCRIPTION				
N PANEL RECEPTACLE PLUG				
PART NO.				
172196				
DWG. NO.	172196.DWG	REV. C	SIZE A	SCALE NA