

IS31AP2031 CLASS-K AUDIO POWER AMPLIFIER EVALUATION BOARD GUIDE

DESCRIPTION

The IS31AP2031 is a Class-K audio power amplifier with automatic gain control. It drives up to 2.0W (10% THD+N) into an 8Ω speaker from a 4.2V VCC supply. The IS31AP2031 provides low cost, space saving solution for portable equipments which need audio output with higher power by boosting up supply voltage. Its external components just include a few capacitors and resistors (no inductor). The IS31AP2031 use fully differential design to reduce RF noise. The IS31AP2031 integrates de-pop circuitry to reduce pop and click noise during power on/off or shutdown enable operation. The IS31AP2031 also integrates thermal and short circuit protection function.

FEATURES

- Operates from 2.7V to 4.5V
- 2.0W into an 8Ω load from a 4.2V supply (10% THD+N)
- 4 gain levels: 12dB, 16dB, 24dB, 27.5dB
- AGC function
- Pulse Count Control serial interface
- 8kV HBM ESD
- Thermal and short-circuit protection
- Available in QFN-20 (3mm × 3mm).

QUICK START

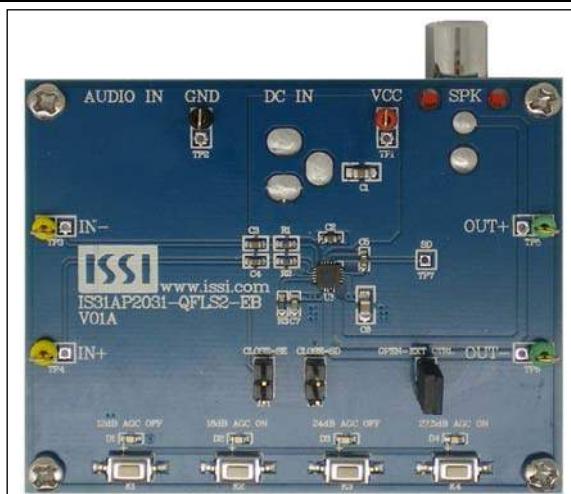

Figure 1: Photo of IS31AP2031 Evaluation Board

RECOMMENDED EQUIPMENT

- ≤ 4.5V, 2A power supply
- Audio source (i.e. MP3 player, Notebook PC, etc.)
- An 8Ω speaker

ABSOLUTE MAXIMUM RATINGS

- ≤ 4.5V power supply

Caution: Do not exceed the conditions listed above; otherwise the board will be damaged

PROCEDURE

The IS31AP2031 demo board is fully assembled and tested. Follow the steps listed below to verify board operation.

Caution: Do not turn on the power supply until all connections are completed.

- 1) Connect an 8Ω (or larger) speaker across the OUT- terminal and OUT+ terminal.
- 2) Connect the ground terminal of the power supply to the GND and the positive terminal to the VCC. Or connect DC power to connector (DC IN).
- 3) If the audio source is differential, remove jumper JP1, connect the negative of the audio source to the IN- terminal, and connect the positive of the audio source to IN+ terminal.
- 4) If the audio source is single-ended, connect the audio source to the IN- terminal, and close jumper JP1; or connect audio source to the audio connector (AUDIO IN) and close jumper JP1.
- 5) Turn on the power supply, and pay attention to the supply current. If the current exceeds 1.5A, please check for circuit fault.
- 6) Turn on the audio source.

ORDERING INFORMATION

Part No.	Temperature Range	Package
IS31AP2031-QFLS2-EB	-40°C to +85°C (Industrial)	QFN-20, Lead-free

Table 1: Ordering Information

For pricing, delivery, and ordering information, please contacts ISSI's analog marketing team at analog@issi.com or (408) 969-660.

IS31AP2031 CLASS-K AUDIO POWER AMPLIFIER EVALUATION BOARD GUIDE

PERFORMANCE DESCRIPTION

The IS31AP2031 evaluation board has four buttons to switch between the different modes. The operating mode is indicated by an LED illuminated above the appropriate buttons. The modes listed as below:

- 1) Mode1: gain level 12dB AGC OFF.
- 2) Mode2: gain level 16dB AGC ON.
- 3) Mode3: gain level 24dB AGC OFF.
- 4) Mode4: gain level 27.5dB: AGC ON.
- 5) Shutdown mode: close Jumper (JP2) enter shutdown mode.

Note: IS31AP2031 Audio Amplifier provides solely the Audio function on the evaluation board.

SOFTWARE SUPPORT

Please refer to the integrated program.

Note: The Jumper JP3 is closed by default, if the JP3 is open, the MCU will stop functioning, the SDB pin of the chip in a high impedance state. The external MCU can be used to control the board SD (TP7) point.

Please refer to the datasheet to get more information about IS31AP2031.

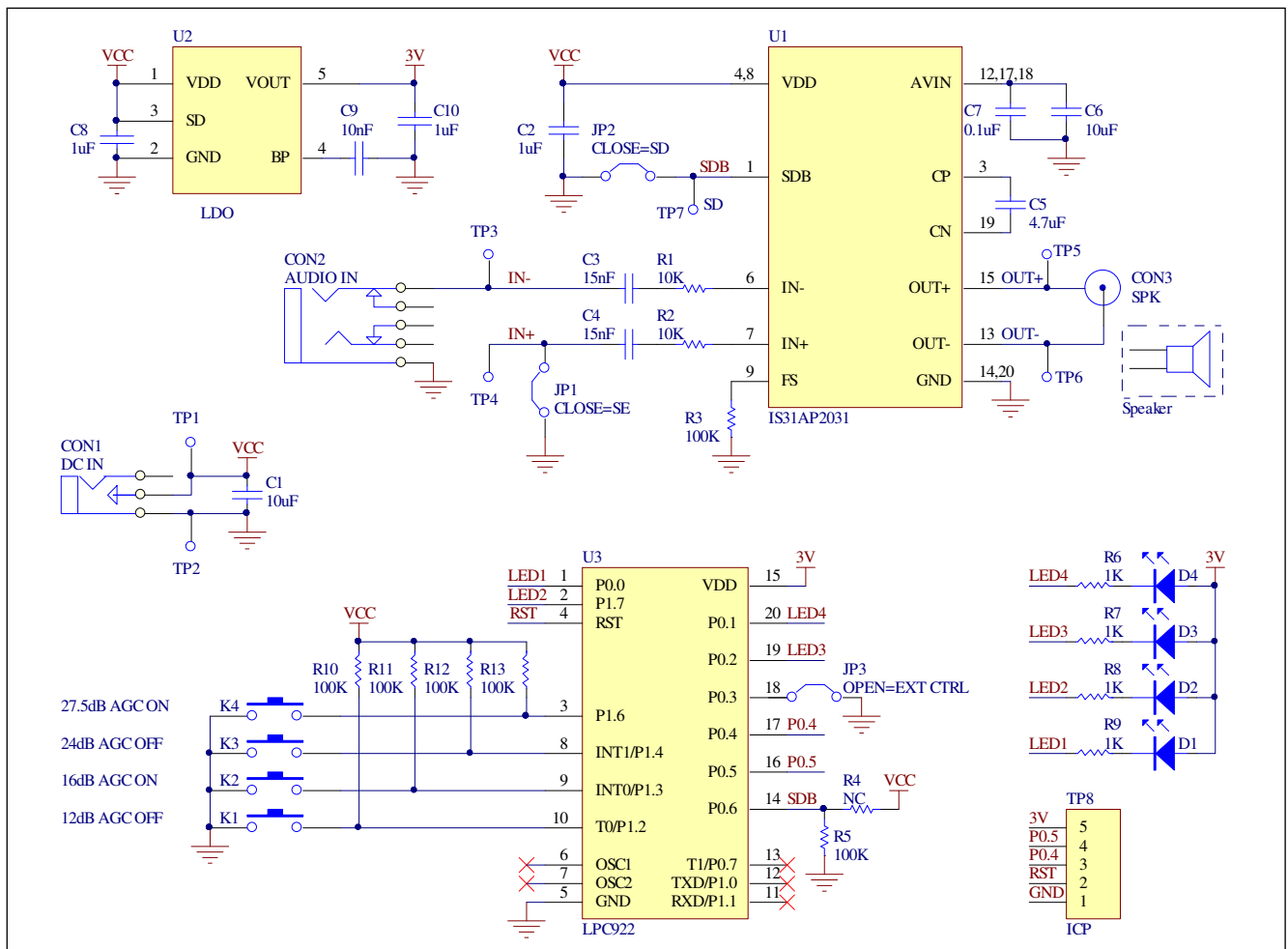

Figure 2: IS31AP2031 Application Schematic



IS31AP2031 CLASS-K AUDIO POWER AMPLIFIER EVALUATION BOARD GUIDE

BILL OF MATERIALS

Name	Symbol	Description	Qty	Supplier	Part No.
Audio Amplifier	U1	Class-K Audio Amplifier	1	ISSI	IS31AP2031
LDO	U2	Low-dropout Regulator	1	PAM	PAM3101
MCU	U3	Microcontroller	1	NXP	LPC922
Diode	D1~D4	Diode, LED Blue, SMD	4	Everlight	19-217/BHC-ZL1M2RY/3T
Resistor	R1,R2	RES,10k,1/16W,±1%,SMD	2	Yageo	RC0603FR-0710KRL
Resistor	R3,R5,R10~R13	RES,100k,1/16W,±5%,SMD	6	Yageo	RC0603JR-07100KRL
Resistor	R6~R9	RES,1k,1/16W,±5%,SMD	4	Yageo	RC0603JR-0701KRL
Resistor	R4	Not Connected	1		
Capacitor	C1,C6	CAP,10µF,10V,±10%,SMD	2	Yageo	CC0805KKX7R6BB106
Capacitor	C2	CAP, 1µF,16V,±10%,SMD	1	Yageo	CC0603KKX7R7BB105
Capacitor	C8,C10	CAP, 1µF,16V,±10%,SMD	2	Yageo	CC0805KKX7R7BB105
Capacitor	C3,C4	CAP, 15nF,16V,±10%,SMD	2	Yageo	CC0603KKX7R7BB153
Capacitor	C5	CAP, 4.7µF,10V,±10%,SMD	1	Yageo	CC0805KKX7R6BB475
Capacitor	C7	CAP, 0.1µF,16V,±10%,SMD	1	Yageo	CC0603KKX7R7BB104
Capacitor	C9	CAP,10nF,16V,±10%,SMD	1	Yageo	CC0603KKX7R7BB103
Button	K1~K4	Button SMD	4		

Bill of Materials, refer to Figure 2 above.

**IS31AP2031 CLASS-K AUDIO POWER AMPLIFIER
EVALUATION BOARD GUIDE**

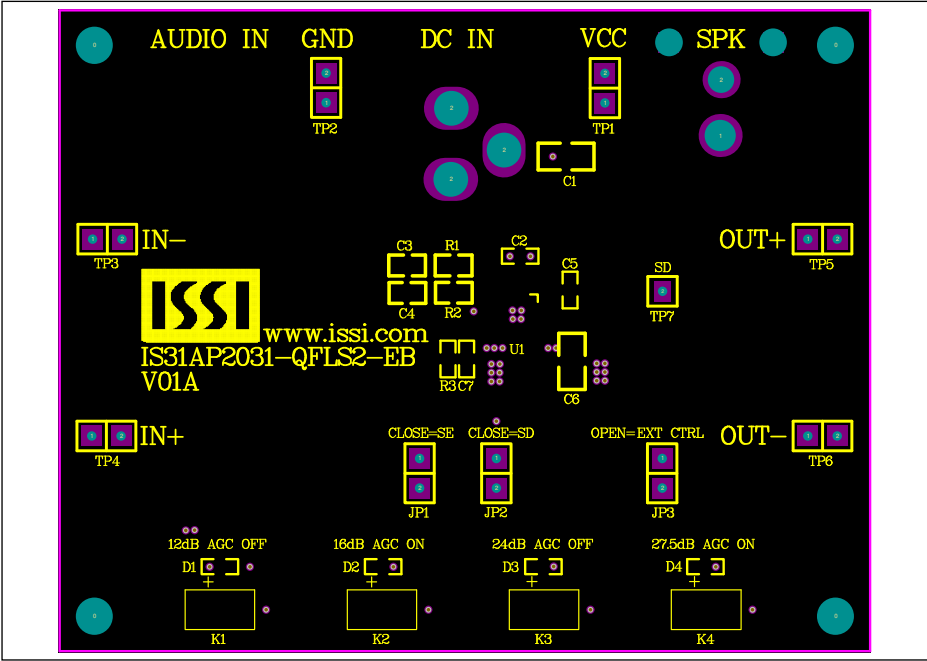

Figure 3: Board Component Placement Guide - Top Layer

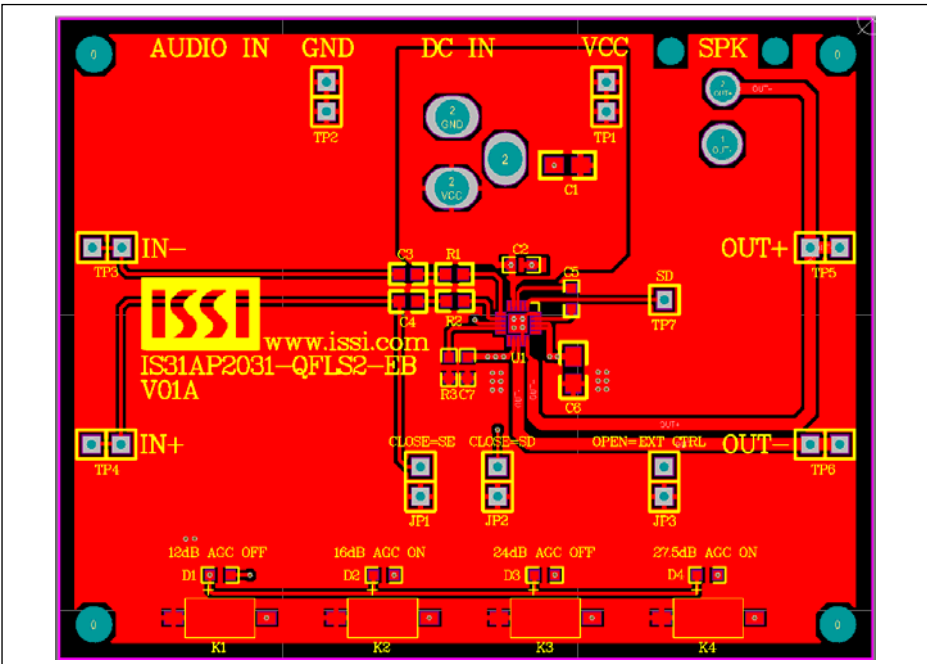

Figure 4: Board PCB Layout - Top Layer

**IS31AP2031 CLASS-K AUDIO POWER AMPLIFIER
EVALUATION BOARD GUIDE**

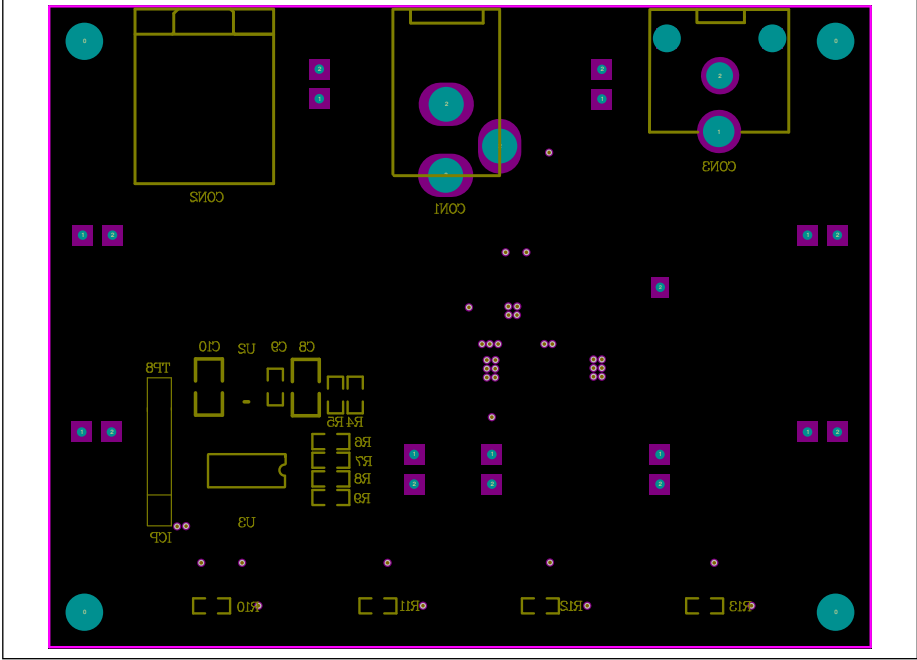

Figure 5: Board Component Placement Guide - Bottom Layer

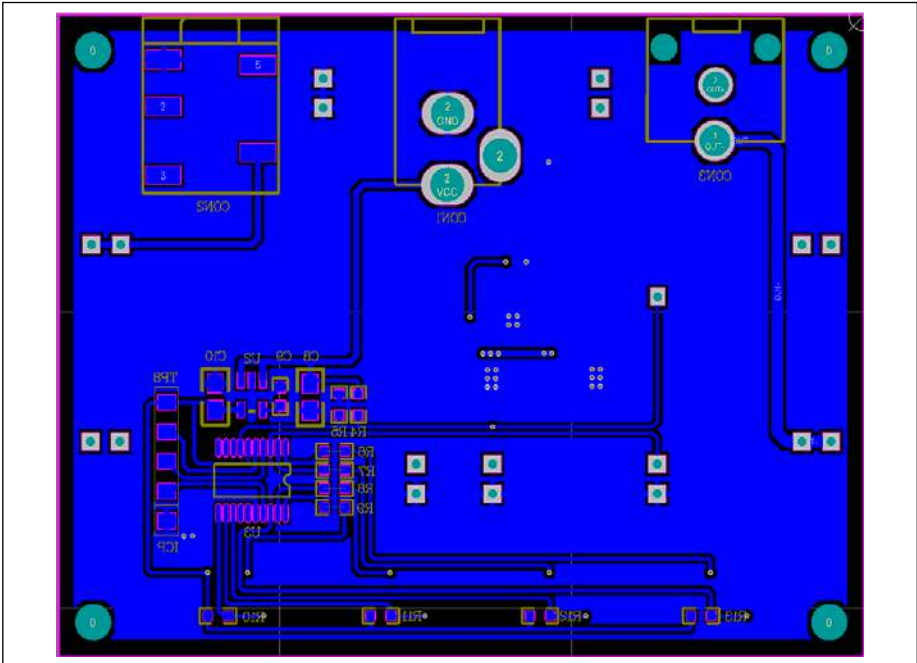

Figure 6: Board PCB Layout - Bottom Layer

Copyright © 2017 Integrated Silicon Solution, Inc. All rights reserved. ISSI reserves the right to make changes to this specification and its products at any time without notice. ISSI assumes no liability arising out of the application or use of any information, products or services described herein. Customers are advised to obtain the latest version of this device specification before relying on any published information and before placing orders for products.

Integrated Silicon Solution, Inc. does not recommend the use of any of its products in life support applications where the failure or malfunction of the product can reasonably be expected to cause failure of the life support system or to significantly affect its safety or effectiveness. Products are not authorized for use in such applications unless Integrated Silicon Solution, Inc. receives written assurance to its satisfaction, that:

- a.) the risk of injury or damage has been minimized;
- b.) the user assume all such risks; and
- c.) potential liability of Integrated Silicon Solution, Inc is adequately protected under the circumstances