

PART NUMBER	REV	FIRST USED
680707-1	B	122500-1
680707-2	B	565435-5
680707-3	B	354500-1

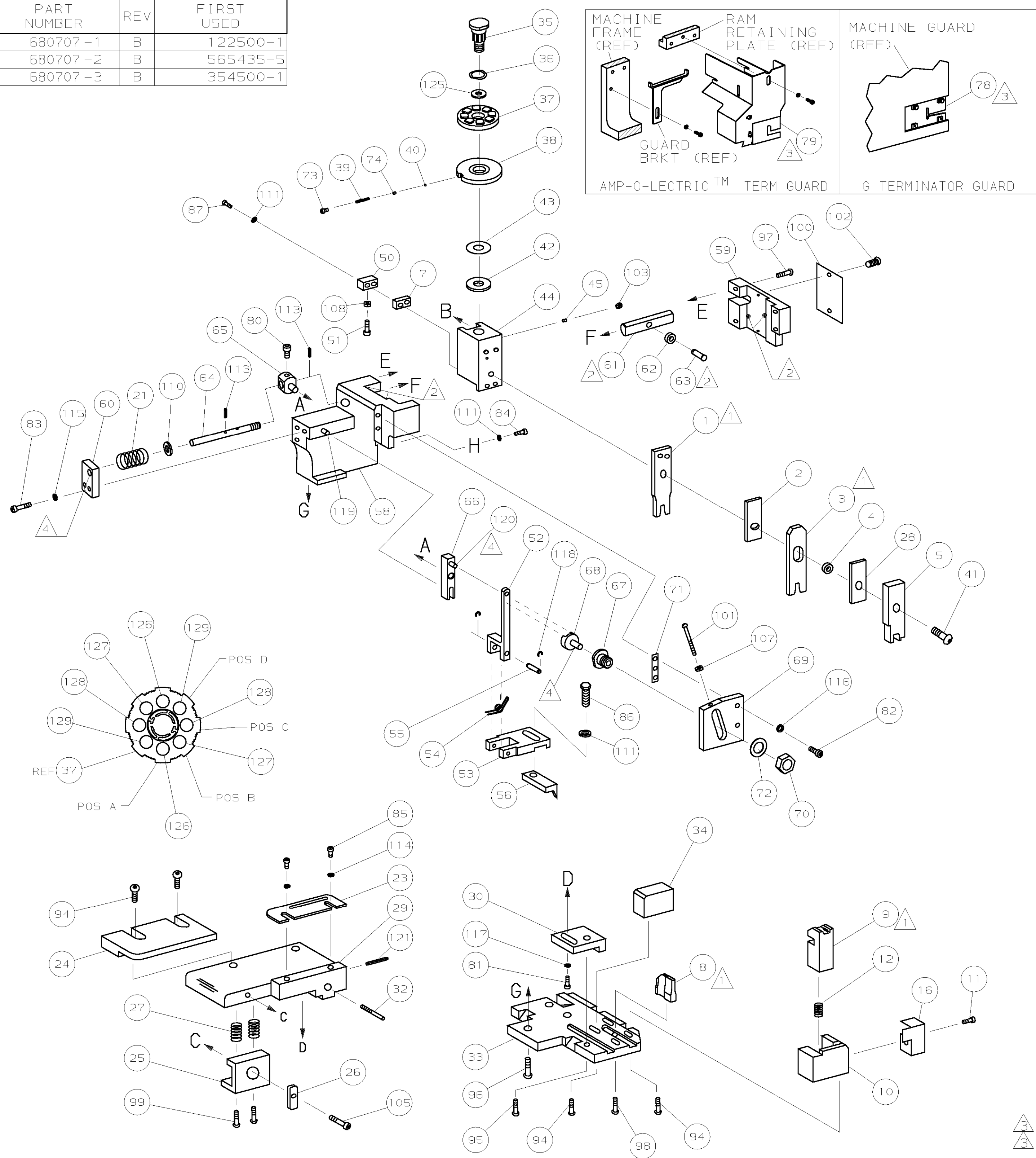
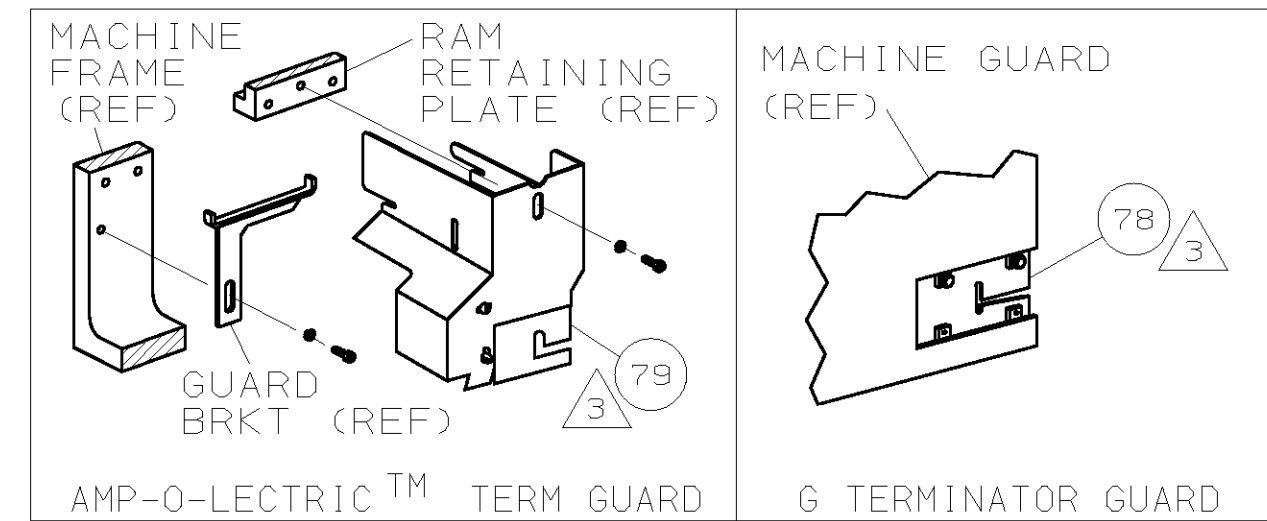

TERMINAL NAME: .062 LONG PIN TYPE III											
CRIMP DATA (AMP TERMINAL)					WIRE STRIP LENGTH						
PAD LTR	CRIMP HEIGHT		WIRE SIZE		TERM	APPL SPEC	FEED	APPL INSTRUCTION	SET UP GAGE	LAYOUT	
A	.061 ±.002 [1.55 ±0.05mm]		2.5 mm <sup>2</sup>		.141-.171	114-10004	.500	408-8040	458637-1	L2141	
B	.057 ±.002 [1.45 ±0.05mm]		2 mm <sup>2</sup>		2	2	2	-	C	3-354779-1	
C	.053 ±.002 [1.35 ±0.05mm]		1.5 mm <sup>2</sup>		2	2	2	-	C	2-354779-3	
D	.049 ±.002 [1.24 ±0.05mm]		1 mm <sup>2</sup>		2	2	2	-	C	1-354779-3	
WIRE	SIZE	TYPE		RANGE	1	1	1	-	A	986950-1	
INSUL	.155 [3.94mm]	F		1mm <sup>2</sup> -2.5mm <sup>2</sup>	1	1	1	WASHER, FLAT PRECISION	125		
					1	1	1	GENERAL INSTRUCTION PACKAGE	124		
					1	1	1	SF APPL INST 408-8040	123		
					1	1	1		122		
					1	1	1	PIN, SLT SPR (ø.093x.75) ST GDE PL	121		
					REF	REF	REF	PIN, DOWEL (ø.187x.50) LEVER	120		
					REF	REF	REF	PIN, DOWEL (ø.187x.1.25) HOUSING	119		
					REF	REF	REF	RING, RET "C" (ø.187) FD FING PIN	118		
					1	1	1	WASHER, LOCK (#10) ADJ BLOCK	117		
					REF	REF	REF	WASHER, LOCK (#10) ADJ PLATE	116		
					REF	REF	REF	WASHER, LOCK (#10) FEED GDE ROD	115		
					2	2	2	WASHER, LOCK (#4) FRONT STP GUIDE	114		
					REF	REF	REF	PIN, SLT SPR (ø.125x.50) ADJ ROD	113		
					4	4	4		112		
					REF	REF	REF	WASHER, LOCK (#8) STRIPPER	111		
					REF	REF	REF	WASHER, FLAT (ø5/16) SCREW ADJ	110		
					1	1	1		109		
					1	1	1	NUT, HEX (NO. 6) HOLDDOWN	108		
					REF	REF	REF	NUT, HEX (6-32) FEED ADJ	107		
									106		
					1	1	1		105		
					1	1	1	SCR, SHLD (ø.187x.25) DRAG LEVER	104		
					1	1	1	PIN, CLEVIS	103		
					1	1	1	SCR, SKT SET (1/4-20x.25 LW) RAM	103		
					2	2	2	SCR, DRIVE (#2x.19) ID PLATE	102		
					REF	REF	REF	SCR, PAN HD (6-32x1.50) FEED ADJ	101		
					1	1	1		100		
					2	2	2	PLATE, IDENTIFICATION	99		
					1	1	1	SCR, BHC (10-32x.88) DRAG	98		
					1	1	1	SCR, BHC (8-32x.38 LW) ANVIL	97		
					REF	REF	REF	SCR, BHC (10-32x.75) CAP	96		
					REF	REF	REF	SCR, BHC (1/4-20x.62) HOUSING	96		
					REF	REF	REF	SCR, BHC (10-32x.50) 5G ADJ BLOCK	95		
					6	6	6	SCR, BHC (8-32x.50) TERM H DWN	94		
									93		
									92		
					1	1	1		91		
					1	1	1	SCR, BHC (6-32x.38) CAM	90		
					1	1	1		89		
					2	2	2	SCR, SHC (4-40x.19) STRIPPER	88		
					2	2	2		87		
					1	1	1	SCR, SHC (8-32x.88) DEP-HOLD	86		
					2	2	2	SCR, HEX HD (8-32x.31) FEED FINGER	85		
					1	1	1	SCR, SHC (4-40x.25) F ST GUIDE	84		
					1	1	1	SCR, SHC (8-32x.50) STRIPPER	83		
					REF	REF	REF	SCR, SHC (10-32x.75) FEED ROD GD	83		
					REF	REF	REF	SCR, SHC (10-32x.62) FD ADJ BLK	82		
					1	1	1	SCR, SHC (10-32x.38) 5G ADJ BL	81		
					REF	REF	REF	SCR, SHC (10-32x.38) PIVOT BLK	80		
					-	REF	-	GUARD, WINDOW	79		
					REF	-	-	INSERT, GUARD	78		
									77		
									76		
					1	1	1		75		
					1	1	1	SPRING, ASSIST	74		
					1	1	1	SCR, SHC (6-32x.25 SL) INS DISC	73		
					REF	REF	REF	WASHER, SPECIAL	72		
					REF	REF	REF	SPACER	71		
					-3	-2	-1	U/M	DWG SIZE		
					PARTS LIST					ITEM NO	
					QTY REOD PER ASSY						

LEADMAKER		MECH POST FEED				
-1	BENCH MODEL K	MECH PRE FEED				
-2	BENCH MODEL G	MECH PRE FEED				
REF	REF	REF	-	B	22594-8	
REF	REF	REF	-	B	240628-1	
REF	REF	REF	-	B	240626-1	
REF	REF	REF	-	B	240633-1	
REF	REF	REF	-	A	455680-1	
REF	REF	REF	-	B	240629-1	
REF	REF	REF	-	A	240632-2	
REF	REF	REF	-	B	240659-3	
REF	REF	REF	-	B	240658-1	
REF	REF	REF	-	B	454398-2	
REF	REF	REF	-	A	454178-1	
REF	REF	REF	-	C	454220-1	
REF	REF	REF	-	D	454485-1	
					57	
1	1	1	-	B	690542-2	
REF	REF	REF	-	B	240624-1	
REF	REF	REF	-	B	691499-1	
REF	REF	REF	-	B	690541-1	
REF	REF	REF	-	A	455679-1	
1	1	1	-	A	811242-2	
1	1	1	-	A	690753-1	
1	-	-	-	B	690602-6	
-	1	-	-	B	690602-5	
-	-	1	-	B	690501-4	
1	1	1	-	B	459456-1	
1	1	1	-	A	690191-1	
1	1	1	-	C	455673-1	
1	1	1	-	A	690125-1	
1	1	1	-	A	690124-1	
1	1	1	-	A	7-21002-9	
1	1	1	-	A	23241-6	
1	1	1	-	A	690170-1	
1	1	1	-	C	690142-1	
1	1	1	-	D	354777-1	
1	1	1	-	A	22480-5	
1	1	1	-	B	690212-1	
1	1	1	-	B	690786-2	
REF	REF	REF	-	D	455675-1	
1	1	1	-	A	690432-3	
REF	REF	REF	-	B	455689-1	
1	1	1	-	C	458144-1	
1	1	1	-	C	1-455888-2	
2	2	2	-	A	1-22284-0	
1	1	1	-	B	240793-1	
1	1	1	-	B	240792-1	
1	1	1	-	D	6-690504-6	
1	1	1	-	A	690438-1	
-	-	1	-	B	690472-2	
REF	REF	REF	-	A	4-22284-9	
1	1	1	-	A	679218-1	
1	1	1	-	B	458949-1	
					18	
					17	
1	1	1	-	B	318563-1	
					15	
					14	
					13	
1	1	1	-	A	5-22280-0	
1	1	1	-	B	690461-2	
1	1	1	-	C	1-690459-0	
1	1	1	-	C	454276-5	
1	1	1	-	C	1-662189-1	
1	1	1	-	C	5-240641-3	
					6	
1	1	1	-	C	1-455889-8	
1	1	1	-	B	1-238011-0	
1	1	1	-	C	7-456134-0	
1	1	1	-	C	455888-1	
1	1	1	-	C	456408-2	
-3	-2	-1	U/M	DWG SIZE	PART NO	
					DESCRIPTION	ITEM NO
					REVISION OF EACH ASSY NO (WHEN BLANK, USE DWG REVISION)	

- 1 RECOMMENDED SPARE PARTS.
- 2 GREASE LIGHTLY.
- 3 GUARD MUST BE IN PLACE WHEN OPERATING APPLICATOR IN A BENCH MACHINE.
- 4 LUBRICATE DAILY USING NO. 20 MACHINE OIL.
- 5. ITEMS WITH QTY OF REF SPECIFIED (EXCEPT ITEMS 78 AND 79) ARE USED ON ITEM 46.

