

Customer Information Sheet

DRAWING No.: H2159-XX

IF IN DOUBT - ASK

©

NOT TO SCALE

THIRD ANGLE PROJECTION

ALL DIMENSIONS IN mm

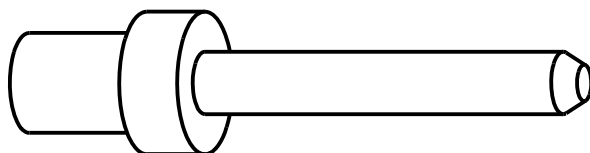
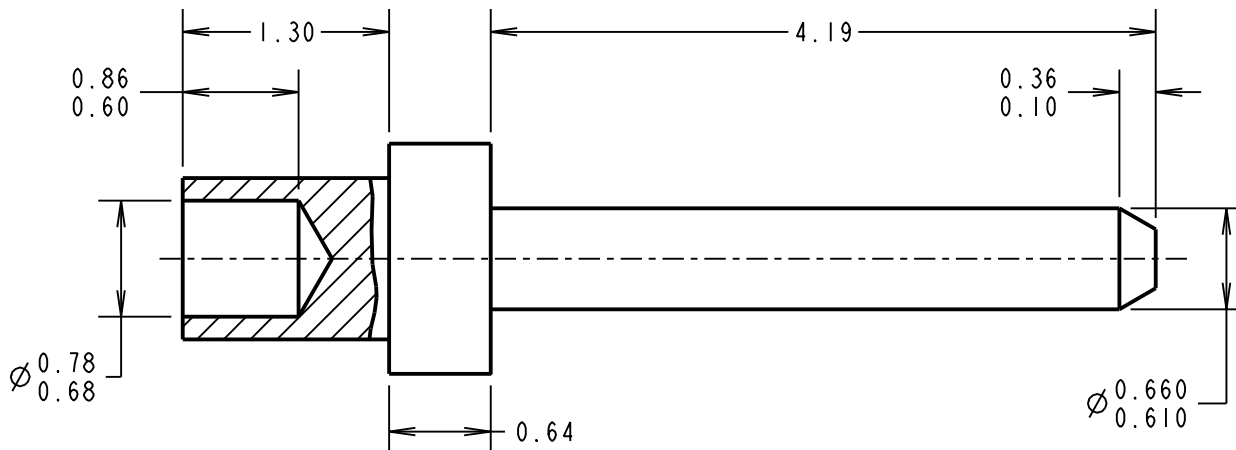
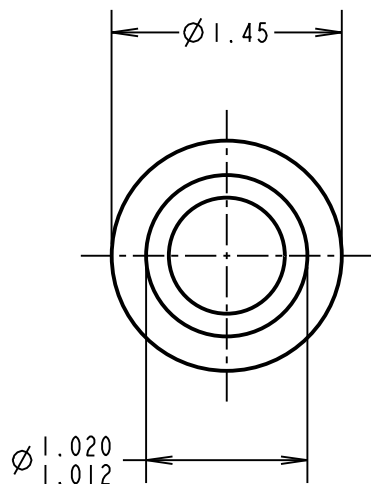

NOTES:

1. UNLESS OTHERWISE STATED, TOLERANCES = ± 0.13 mm.
2. RECOMMENDED HOLE SIZE = $\varnothing 1.07$ - 1.15 mm.
3. FOR USE WITH BOARD THICKNESS 0.80mm.
4. USE PUNCH AND DIE TOOL PART NUMBER Z2159-00.

ORDER CODE:

H2159-XX

FINISH CODE _____

- 01 - 100% TIN OVER NICKEL
- 06 - 90/10 TIN/LEAD

MSP	5	05.06.17	20640
NAME	ISS.	DATE	C/NOTE
APPROVED:		M. PERREN	
CHECKED:		M. PLESTED	
DRAWN:		F. PHILIPSON	
CUSTOMER REF.:			
ASSEMBLY DRG:			

HARWIN

www.harwin.com
technical@harwin.com

THIS DRAWING AND ANY INFORMATION OR DESCRIPTIVE MATTER SET OUT HEREON ARE CONFIDENTIAL AND COPYRIGHT PROPERTY OF THE HARWIN GROUP AND MUST NOT BE DISCLOSED, LOANED, COPIED OR USED FOR MANUFACTURING, TENDERING OR FOR ANY OTHER PURPOSE WITHOUT THEIR WRITTEN PERMISSION.

TOLERANCES	
X.	± 1 mm
X.X	± 0.50 mm
X.XX	± 0.10 mm
X.XXX	± 0.01 mm
ANGLES = $\pm 5^\circ$	
UNLESS STATED	

MATERIAL:	
ANNEALED BRASS CW614N M TO BS EN 12164	
FINISH:	SEE ABOVE
S/AREA:	mm ²

TITLE:	
TERMINAL	
DRAWING NUMBER:	H2159-XX
SHT	2 OF 2