

PART No. MATRIX

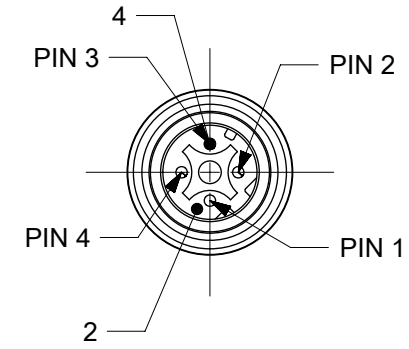

VIEW FROM FRONT SIDE

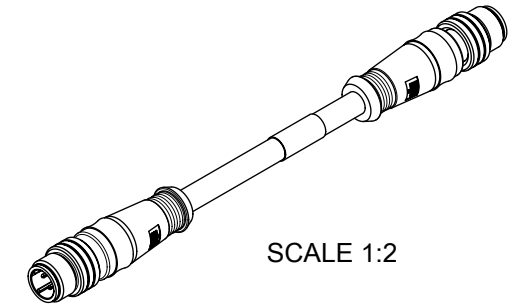
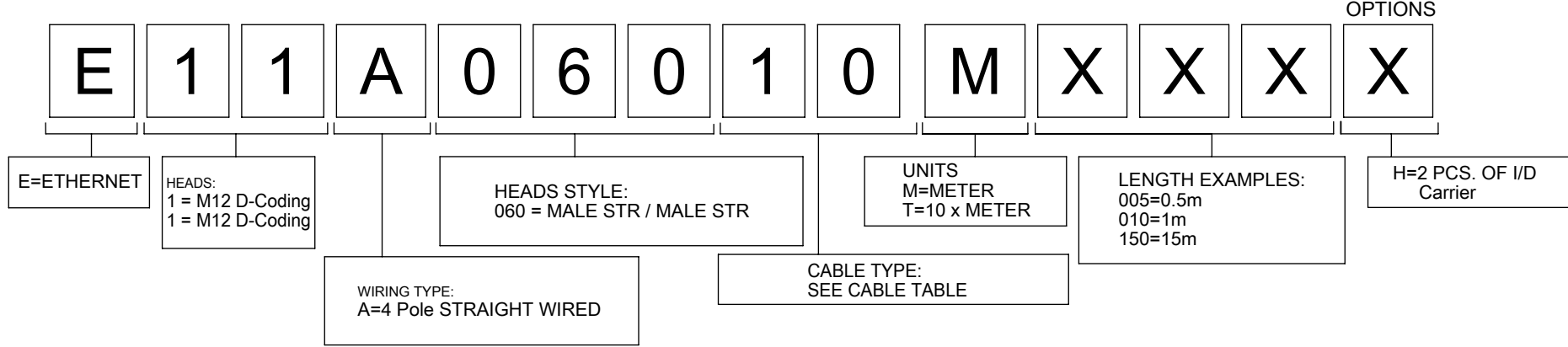
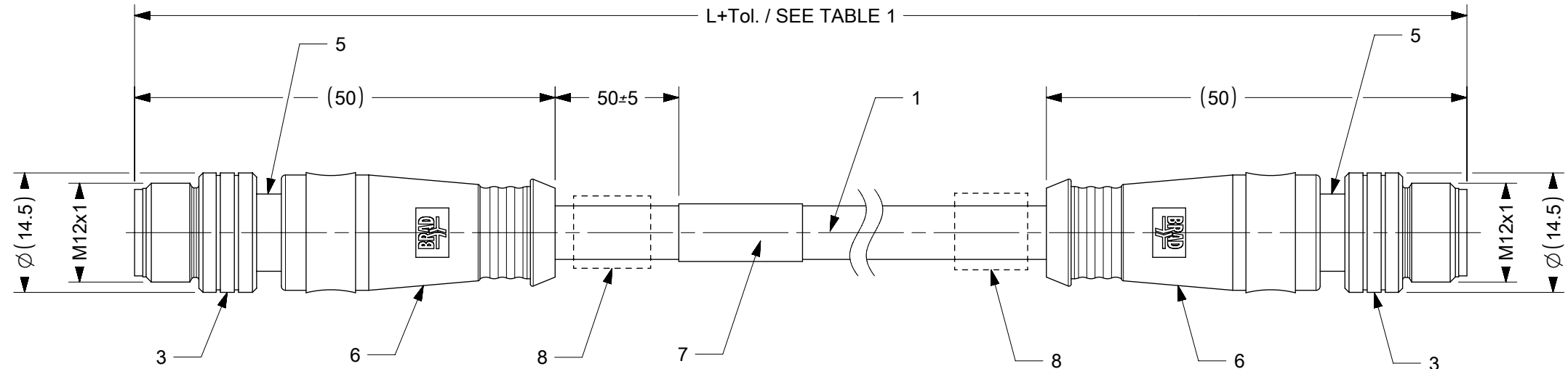

WIRING DIAGRAM

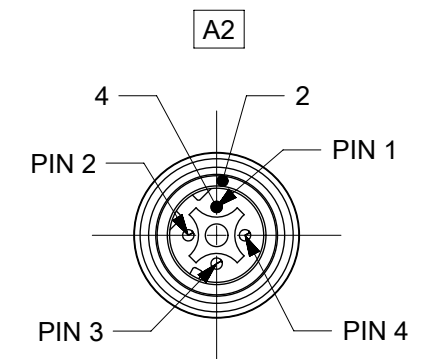

VIEW FROM FRONT SIDE

CONNECTOR SPECIFICATION :
 ACCORDING TO CAT5e ETHERNET STANDARD
 MAX. VOLTAGE : 30V
 MAX. CURRENT : 1.5A
 PROTECTION CLASS : IP67
 TEMPERATURE RANGE : -20°C TO -75°C



NOTES :
 1. SHIELD CONNECTED WITH COUPLING NUTS.
 2. IF IN ENG NO. MATRIX "H"- ID CARRIERS WILL BE ADDED

BOM

ITM	QTY.	DESCRIPTION	MATERIAL	FINISH
1	-	ETHERNET CABLE	PUR	GREEN
2	2	INSERT M12 MA 4P	PA 6	BLACK
3	2	NUT M12 MALE	BRASS	Ni-PLATED
4	8	CONTACT 10 MA	Cu/Ni2	Tinned
5	2	SLEEVE MALE	BRASS	Ni-PLATED
6	-	MOULDING MATERIAL	TPU	BLACK
7	1	LABEL	VINYL	WHITE
8	2	ID CARRIER (SEE NOTE 2)	PVC	TRANSPARENT

DOCUMENT STATUS | P1 | RELEASE DATE | 2018/09/27 14:36:53

CABLE LENGTH TOLERANCE

OVER [mm]	UP TO AND INCLUDING [mm]	TOLERANCES [mm]
0	305	+19
305	915	+45
915	1830	+56
1830	3660	+89
3660	7320	+165
7320	14640	+317
14640	30500	+610
30500	>	+2% of finished length

SYMBOLS	THIS DRAWING CONTAINS INFORMATION THAT IS PROPRIETARY TO MOLEX ELECTRONIC TECHNOLOGIES, LLC AND SHOULD NOT BE USED WITHOUT WRITTEN PERMISSION		CURRENT REV DESC:		
	DIMENSION UNITS: mm SCALE: 1.5:1 GENERAL TOLERANCES (UNLESS SPECIFIED) ANGULAR TOL ± 1.0° 4 PLACES ± 3 PLACES ± 2 PLACES ± 0.05 1 PLACE ± 0.3 0 PLACES ± 0.5 DRAFT WHERE APPLICABLE MUST REMAIN WITHIN DIMENSIONS	EC NO: 605098 DRWN: MCELEJEWSKI 2018/09/27 CHK'D: MIWASIECZKO 2018/09/27 APPR: MIWASIECZKO 2018/09/27 INITIAL REVISION: DRWN: DSTACHOWIAK 2014/09/02 APPR: MIWASIECZKO 2014/09/04	PRODUCT CUSTOMER DRAWING DOCUMENT NUMBER: SD-130048-010 DOC TYPE: PSD DOC PART: 001 REVISION: A2	MATERIAL NUMBER: SEE SHEET 2 CUSTOMER: GENERAL MARKET SHEET NUMBER: 1 OF 2	

CABLE TABLE

CABLE TYPE	WIRE GAUGE	CABLE JACKET	UL	CSA	PERMISSIBLE TEMP RANGE	TRANSPORT TEMP RANGE	DRAG CHAIN TESTED	SHIELD	OTHER
10 : CAT-5E ES	0.34mm ²	PUR GREEN	E119100	-	-40°C TO +70°C	-50°C TO +70°C	5 MIO CYCLES	YES	UV-RESISTANT TENSILE STRENGTH ≤150N

PART LIST

MOLEX PN	ENGINEERING NO	LENGTH(mm)
1201088049	E11A06010M002	200
1300488053	E11A06010M005	500
1300480113	E11A06010M006	600
1300488054	E11A06010M008	800
1300480114	E11A06010M010	1000
1300488055	E11A06010M013	1300
1300480115	E11A06010M020	2000
1300488022	E11A06010M030	3000
1300488112	E11A06010M045	4500
1300480116	E11A06010M050	5000
1300488004	E11A06010M070	7000
1300488011	E11A06010M080	8000
1300480117	E11A06010M100	10000
1201088013	E11A06010M120	12000
1300480118	E11A06010M150	15000
1201088014	E11A06010M180	18000
1300488009	E11A06010M200	20000
1200490455	E11A06010M230	23000
1300488010	E11A06010M250	25000
1201080013	E11A06010M300	30000
1201088713	E11A06010M300H	30000
1201088015	E11A06010M380	38000
1201088016	E11A06010M460	46000
1201088017	E11A06010M530	53000
1300480119	E11A06010M600	60000
1200490458	E11A06010M800	80000
1201088002	E11A06010M900	90000

SYMBOLS	THIS DRAWING CONTAINS INFORMATION THAT IS PROPRIETARY TO MOLEX ELECTRONIC TECHNOLOGIES, LLC AND SHOULD NOT BE USED WITHOUT WRITTEN PERMISSION														
	DIMENSION UNITS		SCALE		CURRENT REV DESC:						molex				
	mm		1:1												
	▽ = 0		GENERAL TOLERANCES (UNLESS SPECIFIED)		EC NO: 605098 DRWN: MCELEJEWSKI 2018/09/27 CHK'D: MIWASIECZKO 2018/09/27 APPR: MIWASIECZKO 2018/09/27						PRODUCT CUSTOMER DRAWING				
	▽ = 0		ANGULAR TOL ± 1.0°												
	▽ = 0		4 PLACES ±												
	▽ = 0		3 PLACES ±		INITIAL REVISION: DRWN: DSTACHOWIAK 2014/09/02 APPR: MIWASIECZKO 2014/09/04						DOCUMENT NUMBER				
	▽ = 0		2 PLACES ± 0.05												
	▽ = 0		1 PLACE ± 0.3		SD-130048-010		PSD	001	A2						
	▽ = 0		0 PLACES ± 0.5												
■ = 0		DRAFT WHERE APPLICABLE MUST REMAIN WITHIN DIMENSIONS		THIRD ANGLE PROJECTION		DRAWING		SERIES		MATERIAL NUMBER		CUSTOMER		SHEET NUMBER	
▽ = 0				B-SIZE		130048		SEE PART LIST		GENERAL MARKET		2 OF 2			