

THIS DRAWING IS UNPUBLISHED. RELEASED FOR PUBLICATION  
 © COPYRIGHT 19 BY AMP INCORPORATED. ALL INTERNATIONAL RIGHTS RESERVED.

PART NO.	WIRE SIZE
861076-1	.107/.113 [2.72/2.87] O.D. TEFLON WIRE
861076-2	.081/.087 [2.06/2.21] O.D. TEFLON WIRE

PROD CODE	LOC	DIST	P	F	ZONE	LTR	REVISIONS DESCRIPTION	DATE	APPD
4092	DF	SO				E	REV 0600-0678-93 TT	09-93	SG
						F	REV PER 0600-4150-95 CT	8-95	DE
						G	REV PER 0600-6380-97 TT	09-97	SG

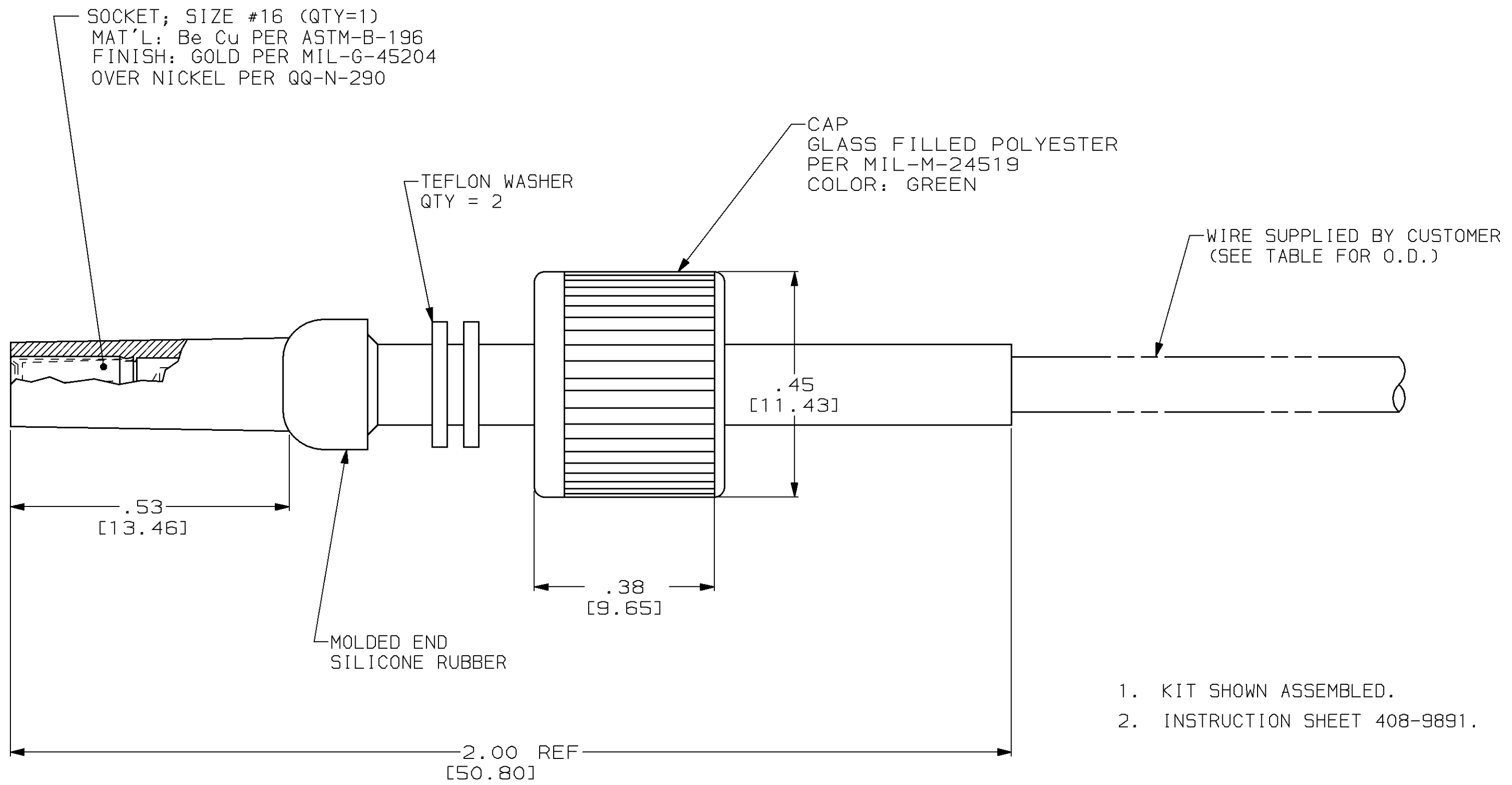

1. KIT SHOWN ASSEMBLED.
2. INSTRUCTION SHEET 408-9891.

DO NOT SCALE PRINT. UNLESS SPECIFIED DIMENSIONS IN INCHES [mm] TOLERANCES ON : 2 PLC DEC ± .02 [0.5] 3 PLC DEC ± .005 [0.127] ANGLES ± -	DR 09-02-93 THOMPSON	<b>AMP</b> AMP INCORPORATED Harrisburg, Pa. 17105			
	CHK 10-20-93 S. GLATFELTER				NAME
	MATERIAL -	APPD 10-20-93 S. GLATFELTER	SIZE	CAGE CODE	DRAWING NO
	FINISH -	APPD 10-20-93 S. GLATFELTER	<b>C</b>	00779	861076
	PRODUCT SPEC -	SCALE	5:1	SHEET	1 OF 1
	APPLICATION SPEC -	WEIGHT	-		