

THIS DRAWING IS UNPUBLISHED. RELEASED FOR PUBLICATION  
 © COPYRIGHT - By - ALL RIGHTS RESERVED.

LOC		DIST		REVISIONS			
P	LTR	DESCRIPTION	DATE	DWN	APVD		
	U	REV PER ECO-15-016062	09NOV15	KG	CD		

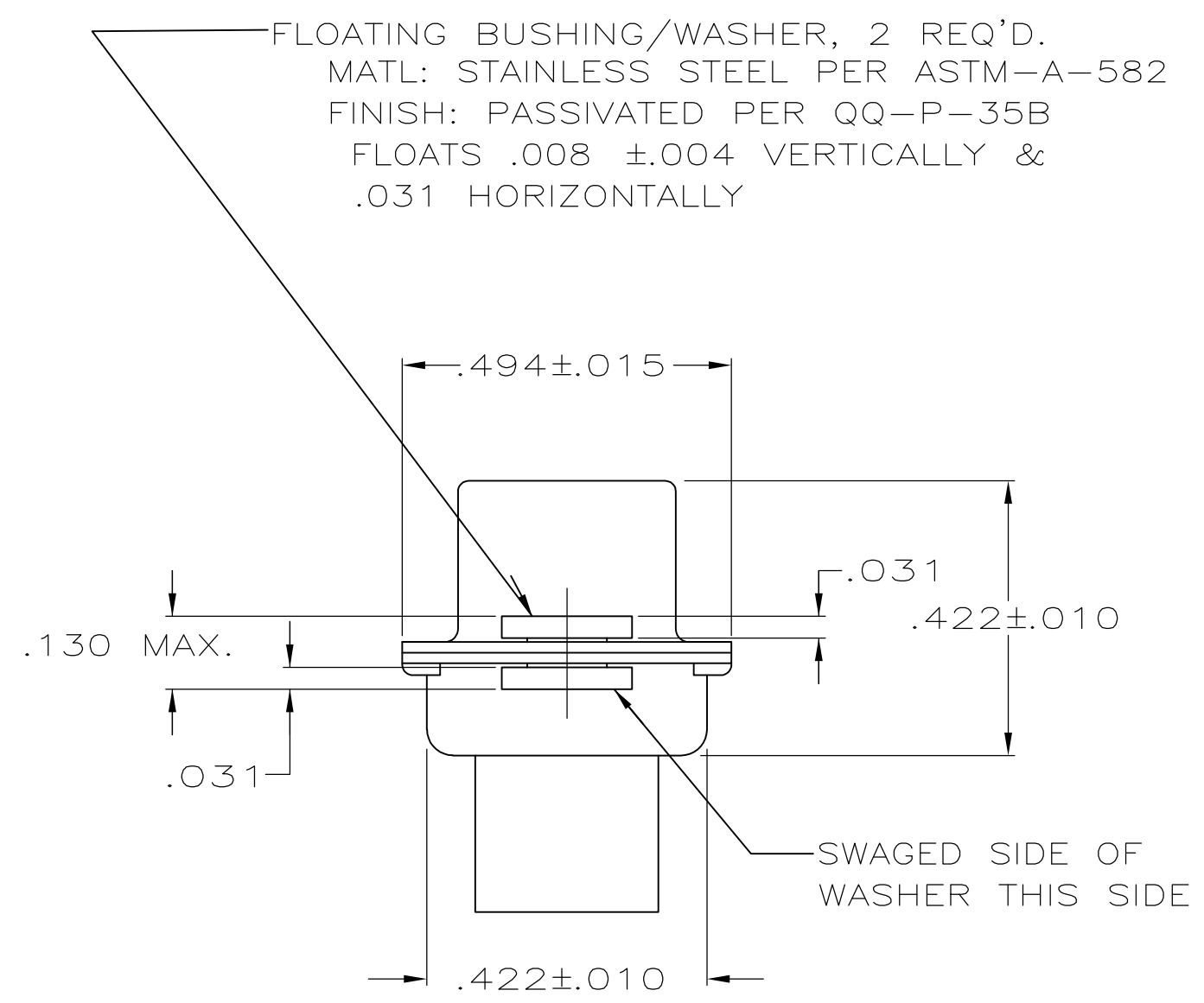
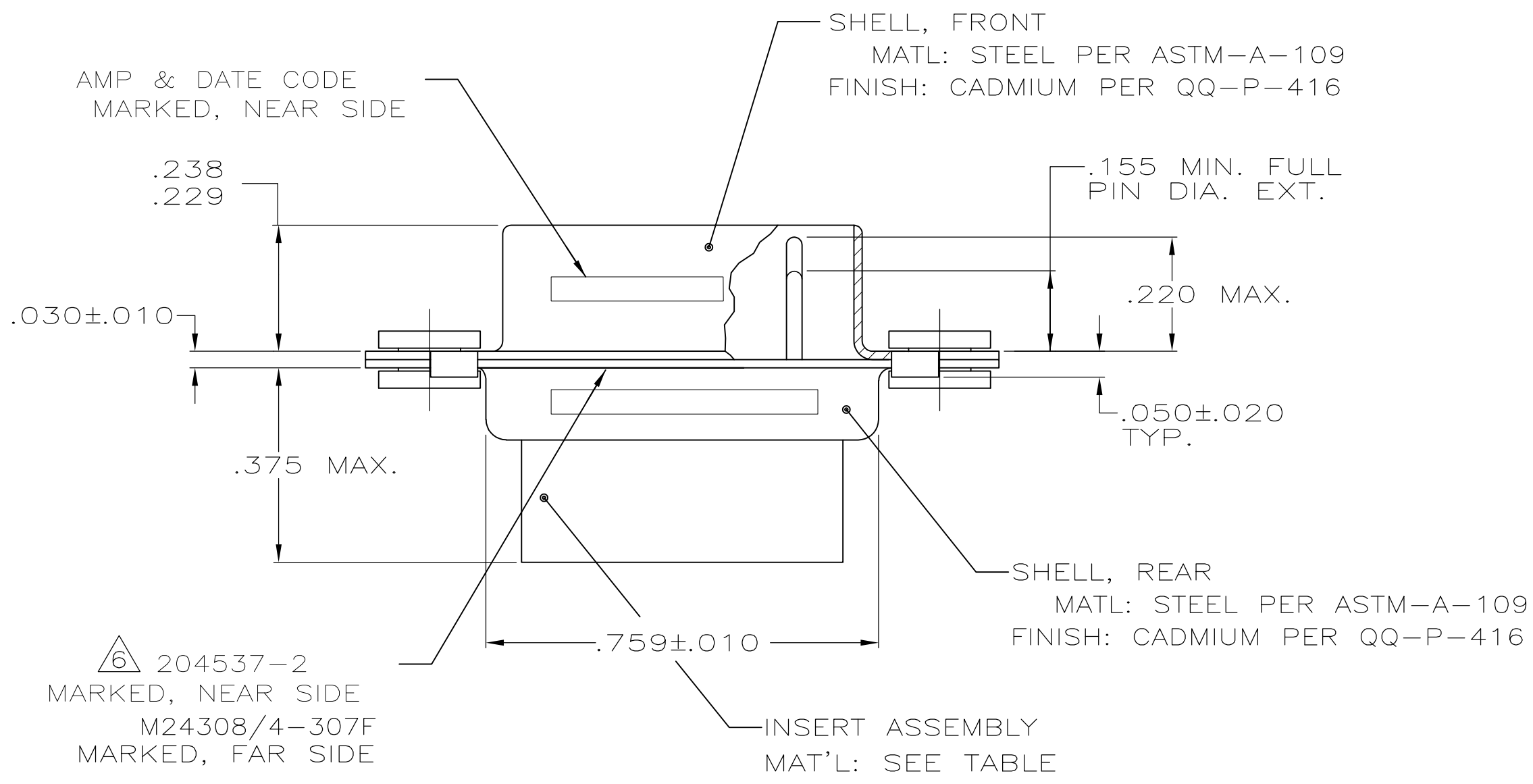
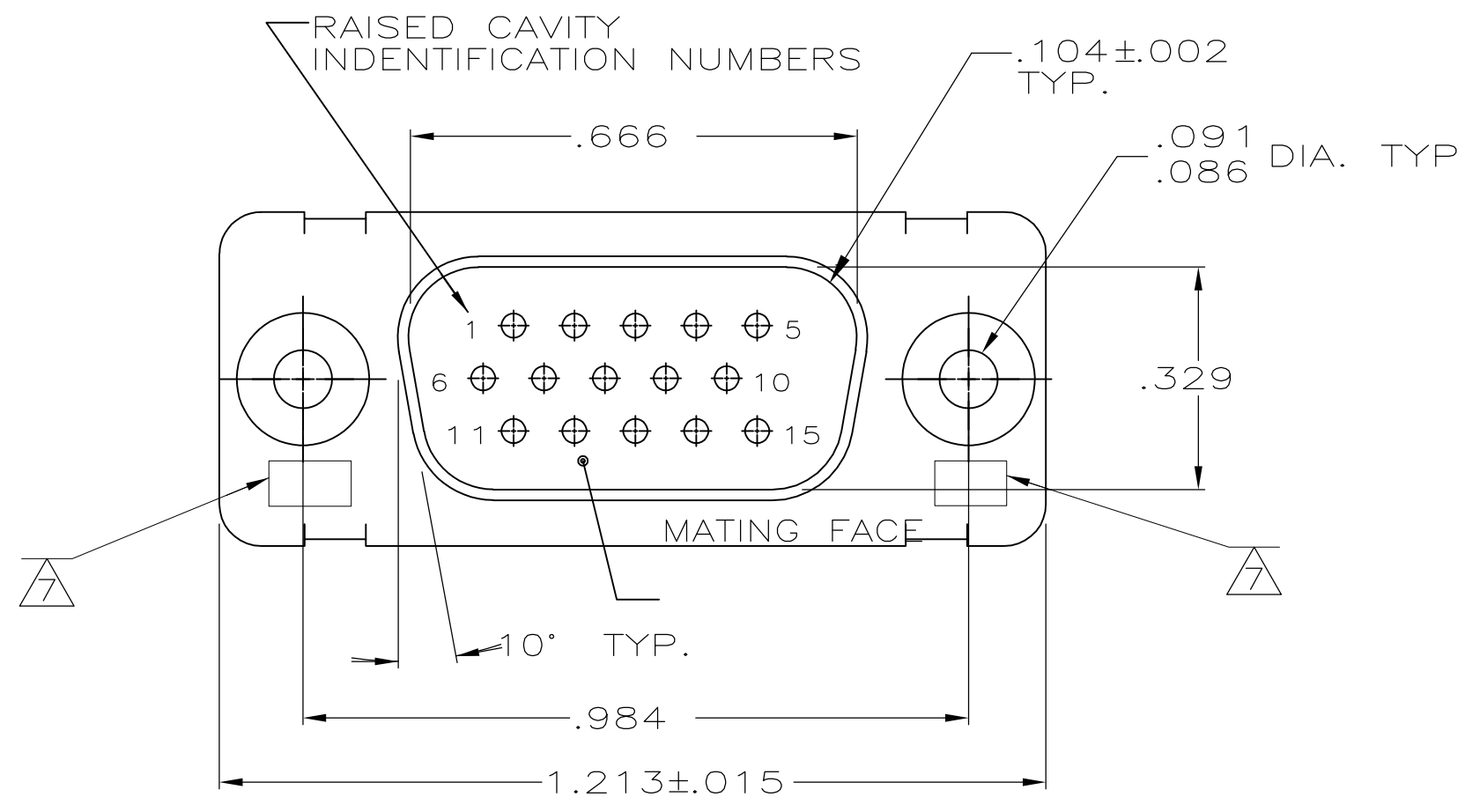

- THIS PLUG IS DESIGNED TO CONFORM TO THE LATEST ISSUE OF MIL-C-24308
  - MAX WIRE INSUL. TO BE USED WITH THIS PLUG IS .054 DIA.
  - METAL RETENTION CLIPS ARE INCLUDED IN INSERTS
  - PACKAGE MARKED M 24308/4-329F
  - THIS PLUG WILL ACCEPT SIZE 22 PIN CONTACT M 24308/13 OR AMP # 204370
- AMP PART NO. MARKED ON CONNECTOR REPRESENTS KIT NUMBER WITH CONTACTS  
 UL/CSA DESIGNATION MARKED IN THIS AREA.

SUPERSEDED BY 204525-1	PHENOLIC, COLOR: BLACK	204525-2
	POLYPHENYLENE SULFIDE (PPS) GST-40F PER MIL-M-24519 OR GLASS FILLED POLYESTER TPES013G30 PER ASTM D5927 COLOR, BLACK	204525-1
	INSERT MATERIAL	PART NO.

THIS DRAWING IS A CONTROLLED DOCUMENT.		DWN	12-3-87	C.C.THOMAS	
DIMENSIONS: INCHES		CHK	1-25-88	F.BALLEW III	
TOLERANCES UNLESS OTHERWISE SPECIFIED:		APVD	-	NAME	
0 PLC	± -	PRODUCT SPEC	-	AMPLIMITE PLUG FOR PIN CONTACTS HI-DENSITY D CONN, SIZE 1, SERIES 90, WITH FLOAT BUSHINGS	
1 PLC	± -	APPLICATION SPEC	-	SIZE	A2
2 PLC	± -			CAGE CODE	00779
3 PLC	± .005			DRAWING NO	C=204525
4 PLC	± -			RESTRICTED TO	-
ANGLES	± -			SCALE	4:1
MATERIAL	FINISH	WEIGHT	-	SHEET	1 of 1
SEE CALLOUTS	SEE CALLOUTS	CUSTOMER DRAWING		REV	U