

GP1S44S1J00F

Phototransistor Output, Transmissive Photointerrupter with Actuator and Connector



■ Description

GP1S44S1J00F is a phototransistor output, transmissive photointerrupter with opposing emitter and detector in a case, providing mechanical actuator sensing. For this family of devices, the emitter and detector are inserted in a case, and a 3-pin connector is included to allow remote-mount or off-board designs.

■ Features

1. Transmissive with phototransistor output
2. Highlights :
 - With spring lever type actuator
3. Key Parameters:
 - Actuator lever starting torque (initial):
MAX. 1×10^{-4} N·m
4. Lead free and RoHS directive compliant

■ Agency approvals/Compliance

1. Compliant with RoHS directive

■ Applications

1. General purpose detection of object presence
2. Example : PPC, FAX, Printer

Notice The content of data sheet is subject to change without prior notice.
In the absence of confirmation by device specification sheets, SHARP takes no responsibility for any defects that may occur in equipment using any SHARP devices shown in catalogs, data books, etc. Contact SHARP in order to obtain the latest device specification sheets before using any SHARP device.

Internal Connection Diagram

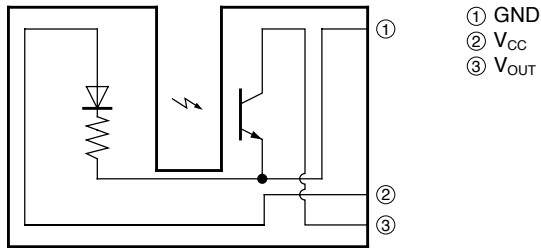

Outline Dimensions

(Unit : mm)

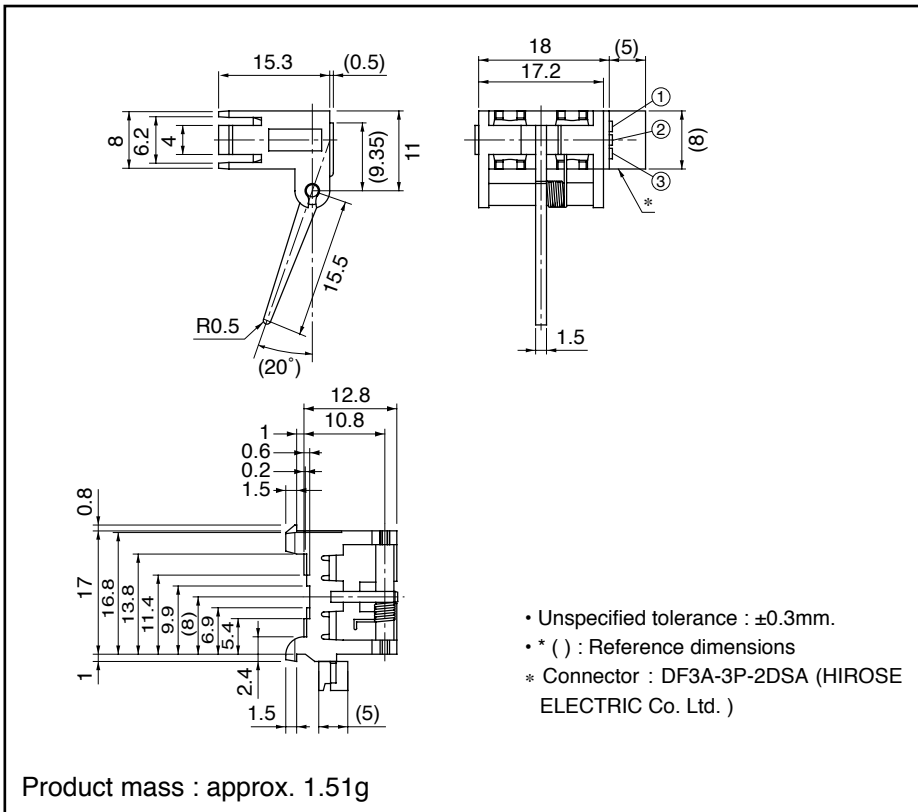

Connector terminal plating material : Sn

Marking

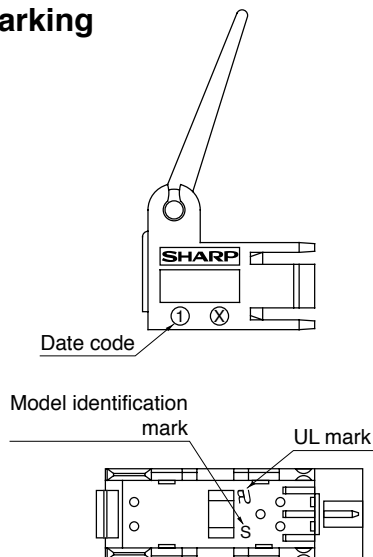

Date code (2 digit)

1st digit		2nd digit	
Year of production		Month of production	
A.D.	Mark	Month	Mark
2000	0	1	1
2001	1	2	2
2002	2	3	3
2003	3	4	4
2004	4	5	5
2005	5	6	6
2006	6	7	7
2007	7	8	8
2008	8	9	9
2009	9	10	X
2010	0	11	Y
:	:	12	Z

repeats in a 10 year cycle

Country of origin

Japan, Philippines

■ Absolute Maximum Ratings (T_a=25°C)

Parameter	Symbol	Rating	Unit
Supply voltage	V _{CC}	-0.5 to +10	V
*1 Output voltage	V _{OUT}	35	V
*2 Output current	I _C	20	mA
*3 Output power dissipation	P _O	75	mW
*4 Operating temperature	T _{opr}	-20 to +75	°C
*4 Storage temperature	T _{stg}	-40 to +85	°C

*1 Collector-emitter voltage of output phototransistor.

*2 Collector current of phototransistor.

*3 Collector current of output phototransistor, refer to Fig.3.

*4 The connector should be plugged in/out at normal temperature.

■ Electro-optical Characteristics (T_a=25°C)

Cordition of Light	Parameter	Symbol	Conditions	MIN.	TYP.	MAX.	Unit
*5 Light beam interrupted	Dissipation current	I _{CC1}	V _{CC} =5V	-	-	20	mA
	Collector current	I _{C1}	Without external disturbing light illuminance, V _{CC} =5V, V _O =5V	-	-	50	μA
*6 Light beam uninterupted	Dissipation current	I _{CC2}	V _{CC} =5V	-	-	20	mA
	Collector current	I _{C2}	Without external disturbing light illuminance, V _{CC} =5V, V _O =5V	0.25	-	-	mA
-	Operating voltage	V _{CC}	T _a =-20 to +75°C	4.5	5	5.5	V

*5 Lever is normal condition on the Fig.1.

*6 Lever is 30° or more movement condition from A point to B point on Fig.1.

Fig.1 Detecting Position

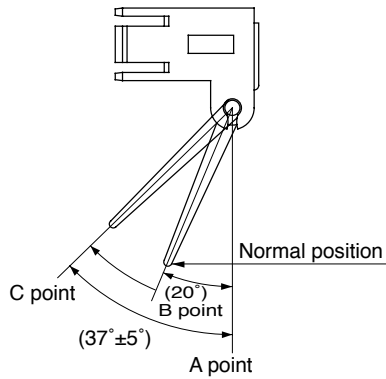

Phototransistor between A point and C point shall be ON-state when the actuator lever rotated ($37^\circ \pm 5^\circ$) from normal condition A point to C point in Fig.1. At this time, Collector current of phototransistor shall be $*I_C/2$.

* I_C is an actual measurement value on collector current in **Electro-optical characteristics**. Normal condition B point shall be opaque condition.

Fig.2 Relative Output of I_C vs. Actuator Lever Angle

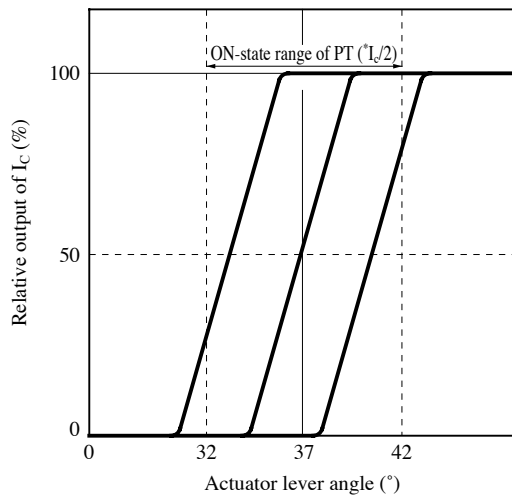

■ Mechanical Characteristics

Lever starting torque : 1×10^{-4} N·m or less

■ Lever Life

100 000 times or more

(Lever reciprocating operation between normal condition B point and C point at the condition of no load.)

Fig.3 Collector power Dissipation vs. Ambient Temperature

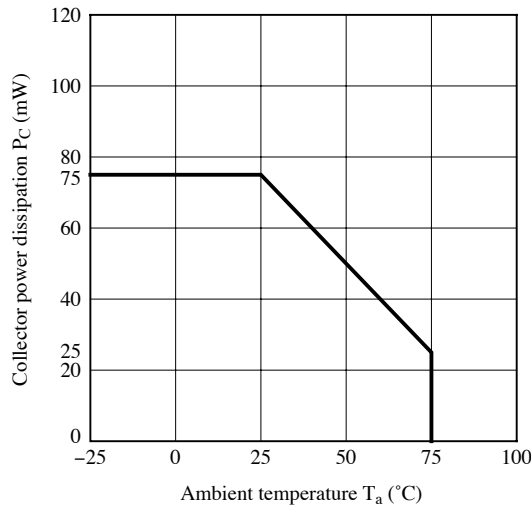

Fig.4 Collector Current vs. Output Voltage

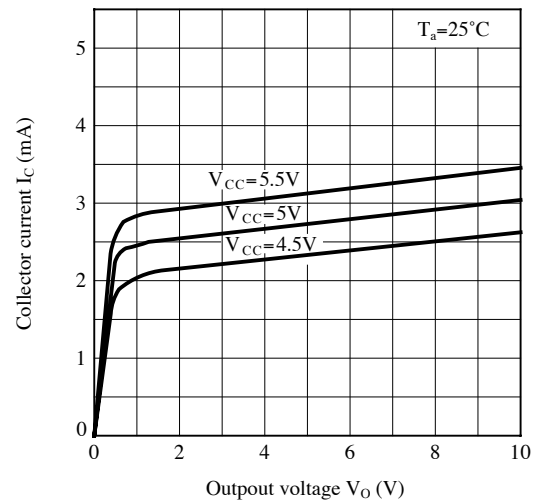

Fig.5 Collector Current vs. Ambient Temperature (2)

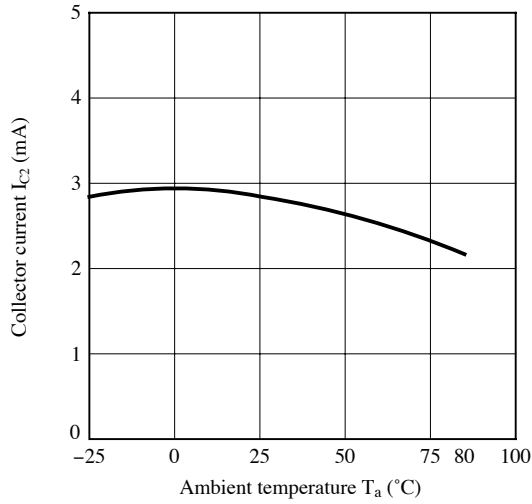

Fig.6 Output Saturation Voltage vs. Ambient Temperature

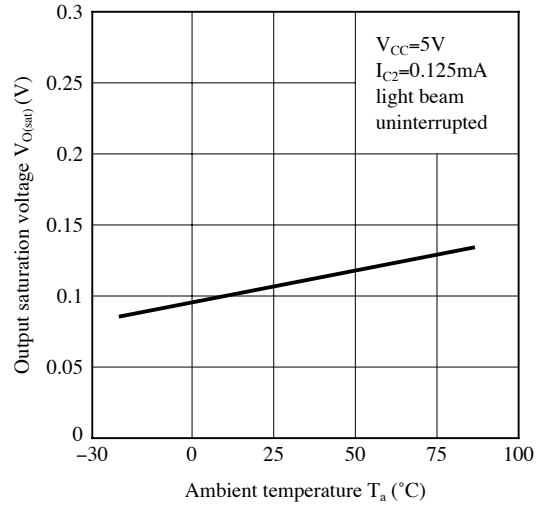
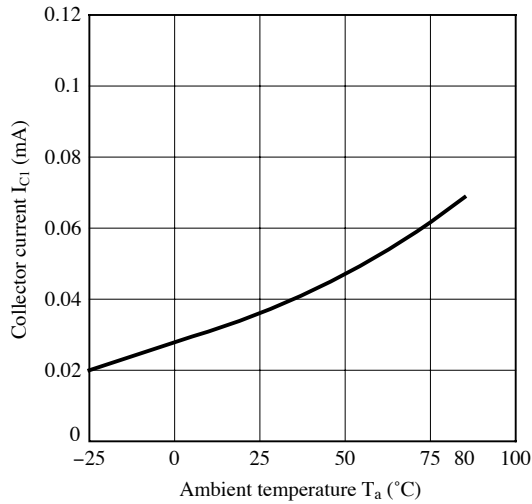

Fig.7 Collector Current vs. Ambient Temperature (1)



Remarks : Please be aware that all data in the graph are just for reference and not for guarantee.

■ **Design Considerations**

● **Design guide**

- 1) Prevention of detection error
To prevent photointerrupter from faulty operation caused by external light, do not set the detecting face to the external light.
- 2) Plug in/out of connector and using of hook should be carried out at normal temperature.
- 3) In case that the detection object is detected by actuator lever, please design to incline 30° or more the lever from normal condition. And please design not to add the external strength on the lever when the lever is reset.
- 4) There is a case that lever is consumed by detecting object.
Please confirm by the actual application.

This product is not designed against irradiation and incorporates non-coherent IRED.

● **Degradation**

In general, the emission of the IRED used in photocouplers will degrade over time.
In the case of long term operation, please take the general IRED degradation (50% degradation over 5 years) into the design consideration.

● **Parts**

This product is assembled using the below parts.

• **Photodetector (qty. : 1)**

Category	Material	Maximum Sensitivity wavelength (nm)	Sensitivity wavelength (nm)	Response time (μs)
Phototransistor	Silicon (Si)	800	400 to 1 200	3

• **Photo emitter (qty. : 1)**

Category	Material	Maximum light emitting wavelength (nm)	I/O Frequency (MHz)
Infrared emitting diode (non-coherent)	Gallium arsenide (GaAs)	950	0.3

• **Material**

Case	Actuator lever
Black polycarbonate resin (UL94 V-2)	Black polycarbonate resin (UL94 HB)

● **Recommended Installation Hole drawing**

- 1) We recommend to fix the product at punching side on the fixing plate (metal plate).
- 2) Please decide the final dimensions at your side after confirmation by the actual applications, Because mounting efficiency and mounted stabilization are dependent on mounting plate corner-curve and punched state.
- 3) Tolerance shall be $\pm 0.1\text{mm}$

Normal mounting type

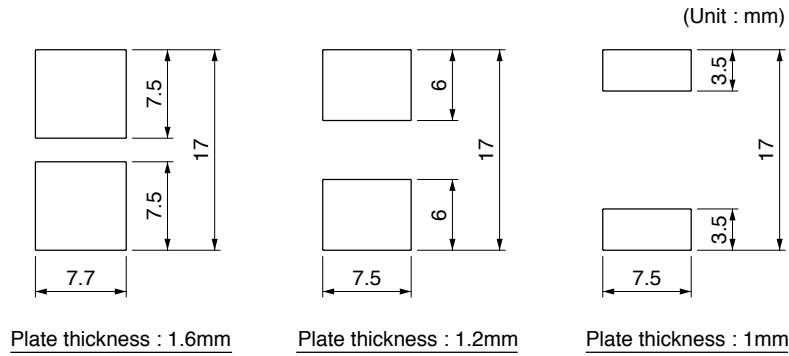

■ Manufacturing Guidelines**● Cleaning instructions**

Solvent cleaning :

Please don't carry out washing so that there is moving portion in this device. (Please remove dust and refuse by blower)

● Presence of ODC

This product shall not contain the following materials.

And they are not used in the production process for this product.

Regulation substances : CFCs, Halon, Carbon tetrachloride, 1.1.1-Trichloroethane (Methylchloroform)

Specific brominated flame retardants such as the PBBOs and PBBs are not used in this product at all.

This product shall not contain the following materials banned in the RoHS Directive (2002/95/EC).

•Lead, Mercury, Cadmium, Hexavalent chromium, Polybrominated biphenyls (PBB), Polybrominated diphenyl ethers (PBDE).

■ Package specification**Package materials**

Tray : Polystyrene

Pad : Corrugated fiberboard

Packing case : Corrugated fiberboard

Package method

100 pcs of products shall be packaged in a plastic bag, Ends shall be fixed by stoppers. The pad shall be put on top of the tray.

And 2 plastic trays shall be put in the packing case. (1 packing contains 200 pcs).

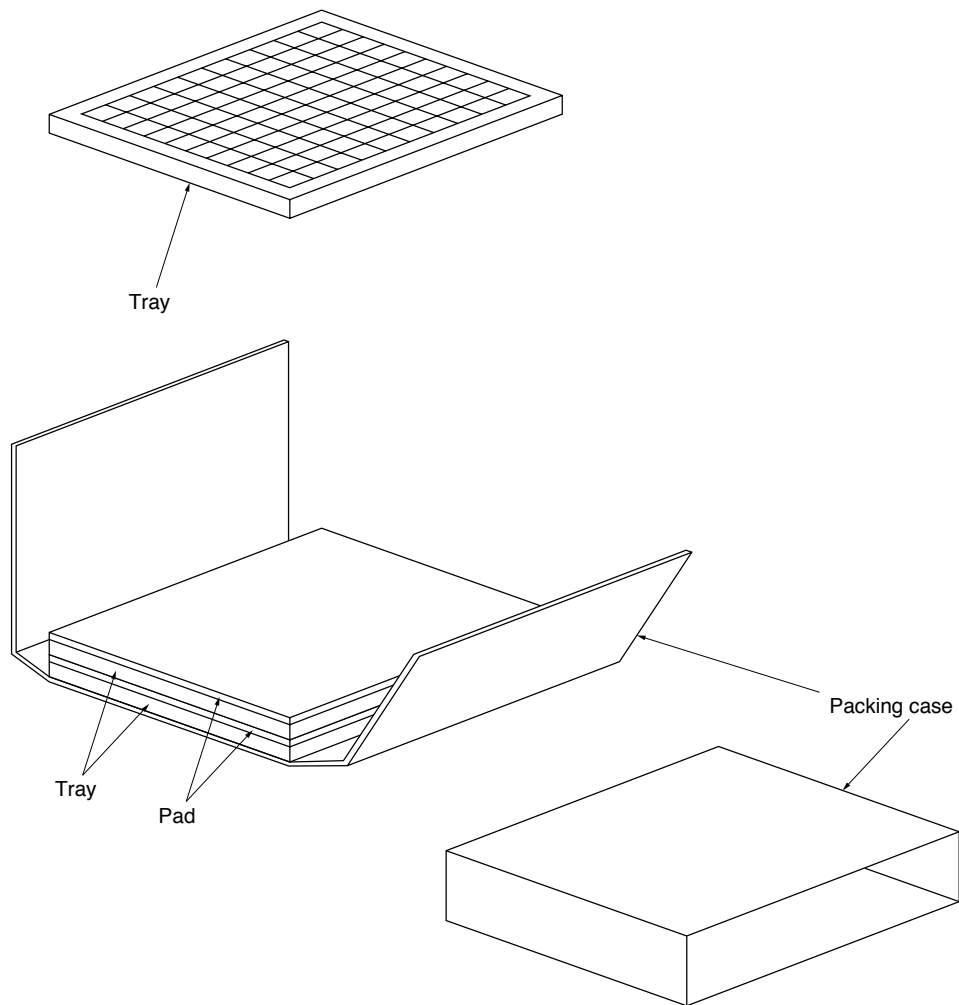
Packing composition

■ Important Notices

· The circuit application examples in this publication are provided to explain representative applications of SHARP devices and are not intended to guarantee any circuit design or license any intellectual property rights. SHARP takes no responsibility for any problems related to any intellectual property right of a third party resulting from the use of SHARP's devices.

· Contact SHARP in order to obtain the latest device specification sheets before using any SHARP device. SHARP reserves the right to make changes in the specifications, characteristics, data, materials, structure, and other contents described herein at any time without notice in order to improve design or reliability. Manufacturing locations are also subject to change without notice.

· Observe the following points when using any devices in this publication. SHARP takes no responsibility for damage caused by improper use of the devices which does not meet the conditions and absolute maximum ratings to be used specified in the relevant specification sheet nor meet the following conditions:

(i) The devices in this publication are designed for use in general electronic equipment designs such as:

- Personal computers
- Office automation equipment
- Telecommunication equipment [terminal]
- Test and measurement equipment
- Industrial control
- Audio visual equipment
- Consumer electronics

(ii) Measures such as fail-safe function and redundant design should be taken to ensure reliability and safety when SHARP devices are used for or in connection

with equipment that requires higher reliability such as:

- Transportation control and safety equipment (i.e., aircraft, trains, automobiles, etc.)
- Traffic signals
- Gas leakage sensor breakers
- Alarm equipment
- Various safety devices, etc.

(iii) SHARP devices shall not be used for or in connection with equipment that requires an extremely high level of reliability and safety such as:

- Space applications
- Telecommunication equipment [trunk lines]
- Nuclear power control equipment
- Medical and other life support equipment (e.g., scuba).

· If the SHARP devices listed in this publication fall within the scope of strategic products described in the Foreign Exchange and Foreign Trade Law of Japan, it is necessary to obtain approval to export such SHARP devices.

· This publication is the proprietary product of SHARP and is copyrighted, with all rights reserved. Under the copyright laws, no part of this publication may be reproduced or transmitted in any form or by any means, electronic or mechanical, for any purpose, in whole or in part, without the express written permission of SHARP. Express written permission is also required before any use of this publication may be made by a third party.

· Contact and consult with a SHARP representative if there are any questions about the contents of this publication.