

External View

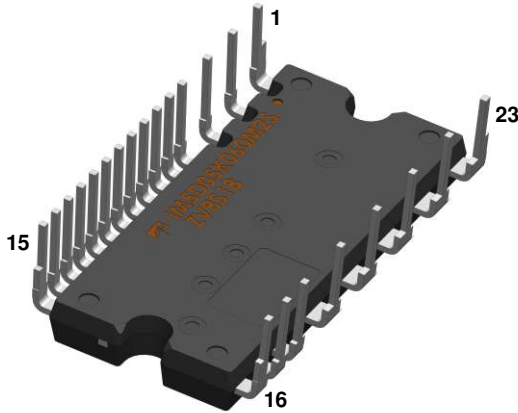

Size: 33.4 x 15 x 3.6 mm

Features

- UL Recognized: UL1557 File E345245
- 600V-5A (Trench Shielded Planar Gate IGBT)
- 3 phase Inverter module including HVIC drivers
- Built-in bootstrap diodes with integrated current-limiting resistor
- Control supply under-voltage lockout protection (UVLO)
- Over-temperature (OT) protection (V_{OT}) – pin open
- Temperature monitoring (V_{OT}) – 10k Ω resistor connection
- Short-circuit current protection (C_{SC})
- Fault out signal (V_{FO}) corresponding to SC, UV and OT fault
- Wide input interface (3-18V), Schmitt trigger receiver circuit (Active High)
- Isolation ratings of 2000Vrms/min

Applications

- AC 100-240Vrms class low power motor drives like refrigerator, dishwasher, fan motor, washing machine, and air-conditioner



Internal Equivalent Circuit / Pin Configuration

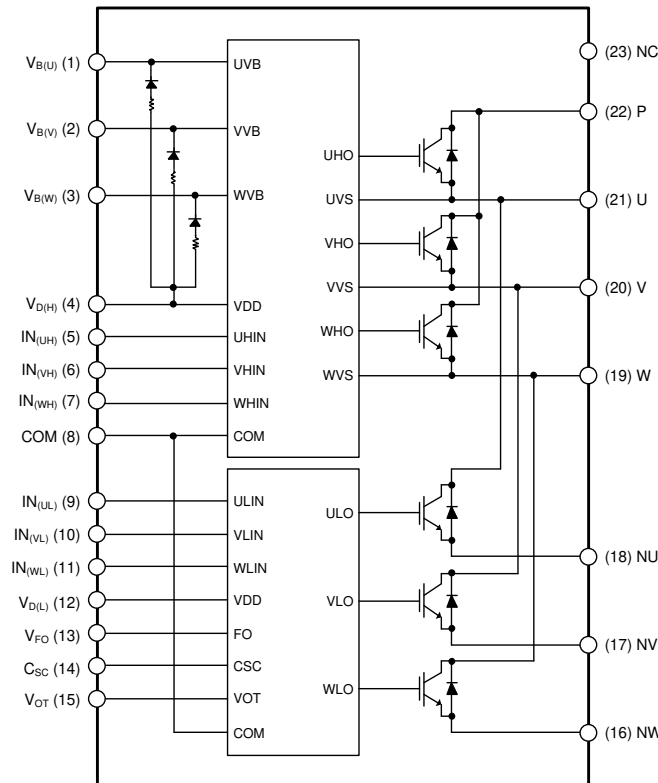

Ordering Information

Part Number	Temperature Range	Package	Pin Length Description
AIM5D05K060M2	-40°C to 150°C	IPM-5	Normal
AIM5D05K060M2S	-40°C to 150°C	IPM-5A	Short



AOS Green Products use reduced levels of Halogens, and are also RoHS compliant. Please visit www.aosmd.com/media/AOSGreenPolicy.pdf for additional information.

Pin Description

Pin Number	Pin Name	Pin Function
1	V _{B(U)}	High-Side Bias Voltage for U-Phase IGBT Driving
2	V _{B(V)}	High-Side Bias Voltage for V-Phase IGBT Driving
3	V _{B(W)}	High-Side Bias Voltage for W-Phase IGBT Driving
4	V _{D(H)}	High-Side Common Bias Voltage for IC and IGBTs Driving
5	IN _(UH)	Signal Input for High-Side U-Phase
6	IN _(VH)	Signal Input for High-Side V-Phase
7	IN _(WH)	Signal Input for High-Side W-Phase
8	COM	Common Supply Ground
9	IN _(UL)	Signal Input for Low-Side U-Phase
10	IN _(VL)	Signal Input for Low-Side V-Phase
11	IN _(WL)	Signal Input for Low-Side W-Phase
12	V _{D(L)}	Low-Side Common Bias Voltage for IC and IGBTs Driving
13	V _{FO}	Fault Output
14	C _{SC}	Capacitor (Low-Pass Filter) for Short-circuit Current Detection Input
15	V _{OT}	Voltage Output of LVIC Temperature
16	NW	Negative DC-Link Input for W-Phase
17	NV	Negative DC-Link Input for V-Phase
18	NU	Negative DC-Link Input for U-Phase
19	W	Output for W-Phase
20	V	Output for V-Phase
21	U	Output for U-Phase
22	P	Positive DC-Link Input
23	NC	No Connection

Absolute Maximum Ratings

T_J = 25°C, unless otherwise specified.

Symbol	Parameter	Conditions	Ratings	Units
Inverter				
V _{PN}	Supply Voltage	Applied between P - NU,NV,NW	450	V
V _{PN(surge)}	Supply Voltage (surge)	Applied between P - NU,NV,NW	500	V
V _{CES}	Collector-Emitter Voltage		600	V
I _C	Output Phase Current	T _C =25°C, T _J <150°C	5	A
		T _C =100°C, T _J <150°C	3	A
±I _{PK}	Output Peak Phase Current	T _C =25°C, less than 1ms pulse width	10	A
t _{SC}	Short Circuit Withstand Time	V _{PN} ≤400V, T _J =150°C, V _D =15V	5	µs
P _C	Collector Dissipation	T _C =25°C, per chip	18.9	W
T _J	Operating Junction Temperature		-40 to 150	°C
Control (Protection)				
V _D	Control Supply Voltage	Applied between V _{D(H)} -COM, V _{D(L)} -COM	25	V
V _{DB}	High-Side Control Bias Voltage	Applied between V _{B(U)} -U, V _{B(V)} -V, V _{B(W)} -W	25	V
V _{IN}	Input Voltage	Applied between I _{N(UH)} , I _{N(VH)} , I _{N(WH)} , I _{N(UL)} , I _{N(VL)} , I _{N(WL)} - COM	V _D ±0.5	V
V _{FO}	Fault Output Supply Voltage	Applied between V _{FO} - COM	5±0.5	V
I _{FO}	Fault Output Current	Sink current at V _{FO} terminal	1	mA
V _{SC}	Current Sensing Input Voltage	Applied between C _{SC} - COM	5±0.5	V
V _{OT}	Temperature Output	Applied between V _{OT} - COM	5±0.5	V
Total System				
V _{PN(PROT)}	Self Protection Supply Voltage Limit (Short-circuit protection capability)	V _D =13.5-16.5V, Inverter part T _J =150°C, Non-repetitive, less than 2µs	400	V
T _C	Module Case Operation Temperature	Measurement point of T _C is provided in Figure 1	-30 to 125	°C
T _{STG}	Storage Temperature		-40 to 150	°C
V _{ISO}	Isolation Voltage	60Hz, sinusoidal, AC 1min, between connected all pins and heat sink plate	2000	V _{rms}

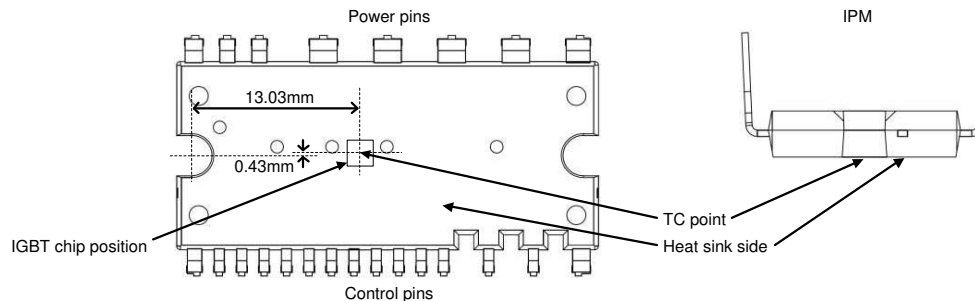

Figure 1. T_C Measurement Point

Thermal Resistance

Symbol	Parameter	Conditions	Min.	Typ.	Max.	Units
R _{th(j-c)Q}	Junction to Case Thermal Resistance ⁽¹⁾	Inverter IGBT (per 1/6 module)	-	-	6.6	K/W
R _{th(j-c)F}		Inverter FWD (per 1/6 module)	-	-	8.5	K/W

Note:

1. For the measurement point of case temperature (T_C), please refer to Figure 1.

Electrical Characteristics

$T_J = 25^\circ\text{C}$, unless otherwise specified.

Symbol	Parameter	Conditions		Min.	Typ.	Max.	Units
Inverter							
$V_{CE(SAT)}$	Collector-Emitter Saturation Voltage	$V_D=V_{DB}=15\text{V}$, $V_{IN}=5\text{V}$	$I_C=2.5\text{A}$, $T_J=25^\circ\text{C}$	-	1.48	1.85	V
			$I_C=2.5\text{A}$, $T_J=125^\circ\text{C}$	-	1.69	-	V
V_F	FWD Forward Voltage	$V_{IN}=0$	$I_F=2.5\text{A}$, $T_J=25^\circ\text{C}$	-	1.75	2.15	V
t_{ON}	Switching Times	$V_{PN}=300\text{V}$, $V_D=V_{DB}=15\text{V}$ $I_C=2.5\text{A}$, $T_J=25^\circ\text{C}$, $V_{IN}=0\text{V} \leftrightarrow 5\text{V}$ Inductive load (high-side)		0.40	0.80	1.40	μs
$t_{C(ON)}$				-	0.10	0.40	μs
t_{OFF}				-	0.85	1.45	μs
$t_{C(OFF)}$				-	0.12	0.30	μs
t_{rr}				-	0.18	-	μs
I_{CES}	Collector-Emitter Leakage Current	$V_{CE}=V_{CES}$	$T_J=25^\circ\text{C}$	-	-	1	mA
			$T_J=125^\circ\text{C}$	-	-	10	mA
Control (Protection)							
I_{QDH}	Quiescent V_D Supply Current	$V_{D(H)}=15\text{V}$, $I_{N(UH, VH, WH)}=0\text{V}$	$V_{D(H)} - \text{COM}$	-	-	0.1	mA
I_{QDL}		$V_{D(L)}=15\text{V}$, $I_{N(UL, VL, WL)}=0\text{V}$	$V_{D(L)} - \text{COM}$	-	-	2.1	mA
I_{QDB}	Quiescent V_{DB} Supply Current	$V_{DB}=15\text{V}$, $I_{N(UH, VH, WH)}=0\text{V}$	$V_{B(U)}-U$, $V_{B(V)}-V$, $V_{B(W)}-W$	-	-	0.3	mA
$V_{SC(ref)}$	Short-Circuit Trip Level	$V_D=15\text{V}^{(2)}$		0.45	0.48	0.51	V
t_{CSC}	C_{SC} Input Filter Time	$V_{SC}=1\text{V}$		-	600	-	ns
UV_{DT}	Supply Circuit Under-Voltage Protection		Trip Level	10.3	11.4	12.5	V
UV_{DR}			Reset Level	10.8	11.9	13.0	V
UV_{DBT}			Trip Level	8.5	9.5	10.5	V
UV_{DBR}			Reset Level	9.5	10.5	11.5	V
V_{OT}	Temperature Output	Pull-down $R=10\text{k}\Omega^{(3)}$	LVIC Temperature= 80°C	2.36	2.45	2.55	V
			LVIC Temperature= 25°C	0.77	1.00	1.25	V
OT_T	Over-Temperature Protection ⁽⁴⁾	$V_D=15\text{V}$, Detect LVIC Temperature	Trip Level	110	130	150	$^\circ\text{C}$
OT_{HYS}			Hysteresis of Trip Reset	-	30	-	$^\circ\text{C}$
V_{FOH}	Fault Output Voltage		$V_{SC}=0\text{V}$, V_{FO} Circuit: 10k Ω to 5V pull-up	4.9	-	-	V
V_{FOL}			$V_{SC}=1\text{V}$, V_{FO} Circuit: 10k Ω to 5V pull-up	-	-	0.5	V
t_{FO}	Fault Output Pulse Width ⁽⁵⁾			20	-	-	μs
I_{IN}	Input Current	$V_{IN}=5\text{V}$		-	1.0	-	mA
$V_{th(on)}$	ON Threshold Voltage				2.3	2.6	V
$V_{th(off)}$	OFF Threshold Voltage	Applied between $I_{N(UH)}$, $I_{N(VH)}$, $I_{N(WH)}$, $I_{N(UL)}$, $I_{N(VL)}$, $I_{N(WL)} - \text{COM}$		0.8	1.2		V
$V_{th(hys)}$	ON/OFF Threshold Hysteresis Voltage			-	1.1	-	V
$V_{F(BSD)}$	Bootstrap Diode Forward Voltage	$I_F=10\text{mA}$ Including Voltage Drop by Limiting Resistor ⁽⁶⁾		1.0	1.5	2.0	V
R_{BSD}	Built-in Limiting Resistance	Included in Bootstrap Diode		80	100	120	Ω

Notes:

- Short-circuit protection works only for low sides.
- The IPM does not shutdown IGBTs and output fault signal automatically when temperature rises excessively. When temperature exceeds the protective level that the user defined, the controller (MCU) should stop the IPM. Temperature of LVIC vs. V_{OT} output characteristics is described in Figure 3.
- When the LVIC temperature exceeds OT Trip temperature level (OT_T), OT protection is triggered and fault outputs.
- Fault signal (F_O) outputs when SC, UV or OT protection is triggered. F_O pulse width is different for each protection mode. At SC failure, F_O pulse width is a fixed width (minimum 20 μs), but at UV or OT failure, F_O outputs continuously until recovering from UV or OT state. (But minimum F_O pulse width is 20 μs).
- The characteristics of bootstrap diodes are described in Figure 2.

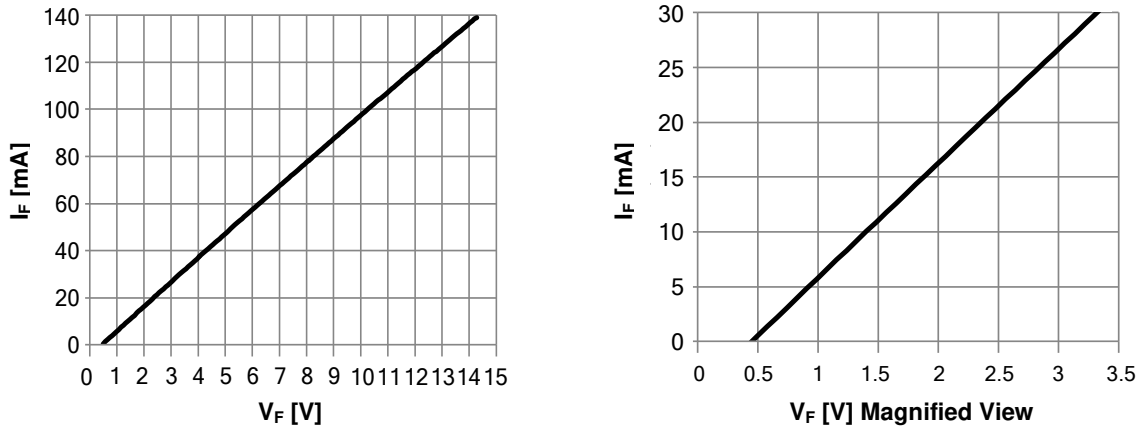

Figure 2. Built-in Bootstrap Diode V_F - I_F Characteristic (@ $T_A=25^\circ\text{C}$)

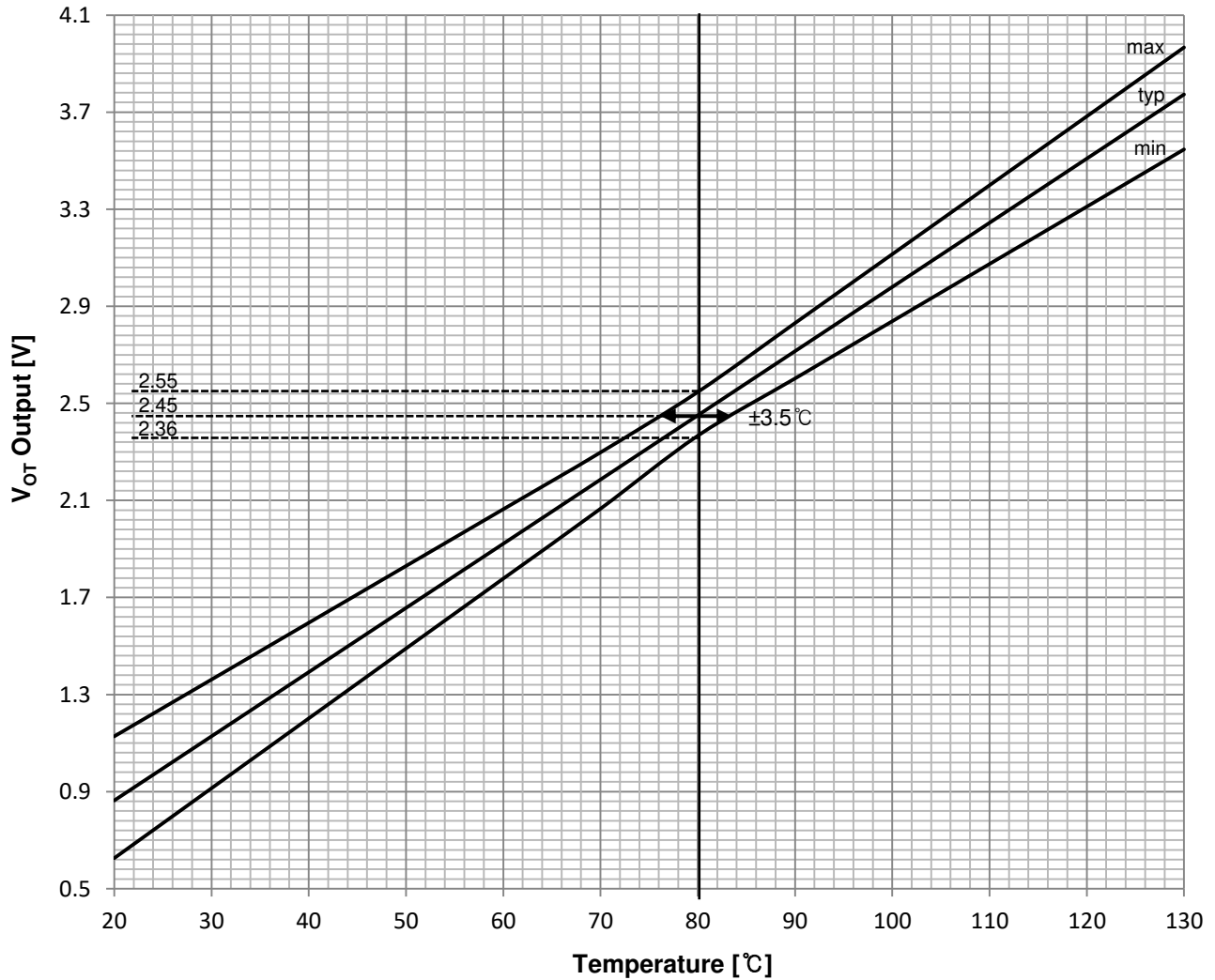

Figure 3. Temperature of LVIC vs. V_{OT} Output Characteristics

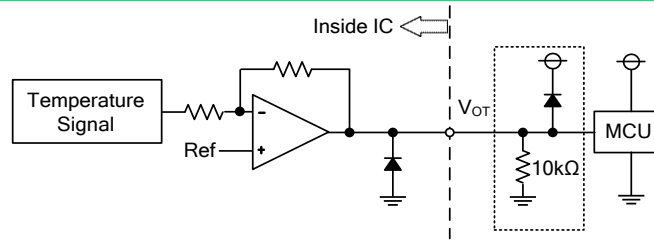

Figure 4. V_{OT} Output Circuit

- (1) Connect 10kΩ to V_{OT} pin if temperature monitoring function is utilized; otherwise if the V_{OT} pin is left unconnected, the internal over-temperature shutdown function is used instead.
- (2) In the case of using V_{OT} with low voltage controller like 3.3V MCU, V_{OT} output might exceed control supply voltage 3.3V when temperature rises excessively. If system uses low voltage controller, it is recommended to insert a clamp diode between control supply of the controller and V_{OT} output for preventing over voltage destruction.

Mechanical Characteristics and Ratings

Symbol	Parameter	Conditions	Min.	Typ.	Max.	Units
Mounting torque	Mounting Screw: M3 ⁽⁷⁾		0.59	0.69	0.78	N m
Weight			-	5.25	-	g
Flatness	Refer to Figure 5		-50	-	100	μm

Note:

7. Plain washers (ISO 7089-7094) are recommended.

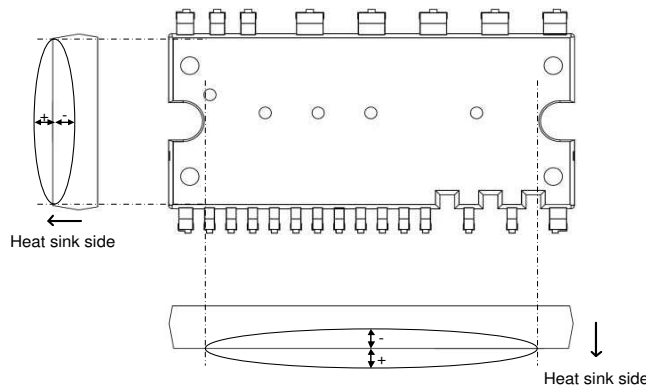

Figure 5. Flatness Measurement Positions

Recommended Operation Conditions

Symbol	Parameter	Conditions	Min.	Typ.	Max.	Units
V _{PN}	Supply Voltage	Applied between P-NU, NV, NW	0	300	400	V
V _D	Control Supply Voltage	Applied between V _{D(H)} - COM, V _{D(L)} - COM	13.5	15.0	16.5	V
V _{DB}	High-Side Bias Voltage	Applied between V _{B(U)} -U, V _{B(V)} -V, V _{B(W)} -W	13.5	15.0	18.5	V
dV _D /dt, dV _{DB} /dt	Control Supply Variation		-1	-	1	V/μs
t _{dead}	Arm Shoot-Through Blocking Time	For each input signal	1.0	-	-	μs
f _{PWM}	PWM Input Frequency	-40°C < T _J < 150°C	-	-	20	kHz
PW _{IN(ON)}	Minimum Input Pulse Width ⁽⁸⁾		0.5	-	-	μs
PW _{IN(OFF)}			0.5	-	-	μs
COM	COM Variation	Between COM - NU, NV, NW (including surge)	-5.0	-	5.0	V

Note:

8. IPM may not respond if the input pulse width is less than PW_{IN(ON)}, PW_{IN(OFF)}.

Time Charts of the IPM Protective Function

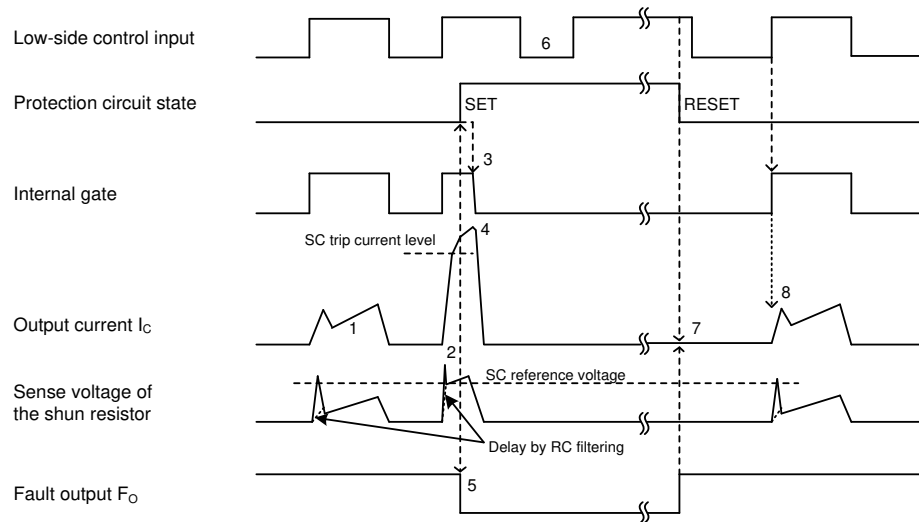

**Figure 6. Short-Circuit Protection
(Low-side Operation Only with the External Shunt Resistor and RC Filter)**

- (1) Normal operation: IGBT turns on and outputs current.
- (2) Short-circuit current detection (SC triggered).
- (3) All low-side IGBTs' gates are hard interrupted.
- (4) All low-side IGBTs turn OFF.
- (5) F_O output time (t_{FO})=minimum 20 μ s.
- (6) Input = "L" : IGBT OFF.
- (7) Fault output finishes, but output current will not turn on until next ON signal (L→H).
- (8) Normal operation: IGBT turns on and outputs current.

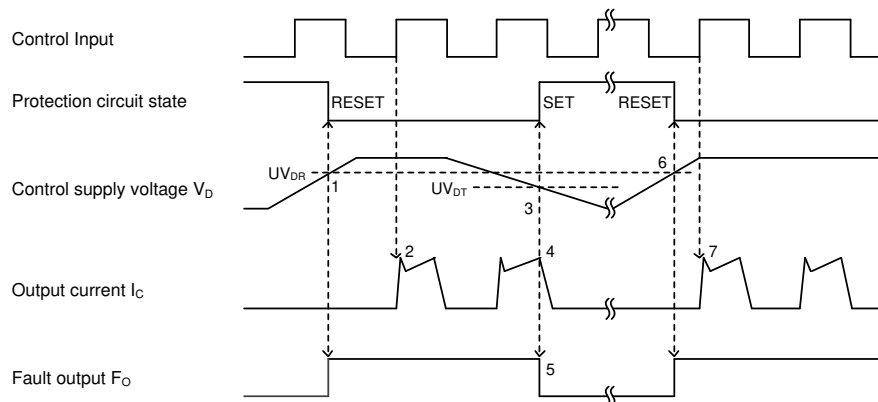

Figure 7. Under-Voltage Protection (Low-side, UV_D)

- (1) Control supply voltage V_D exceeds under voltage reset level (UV_{DR}), but IGBT turns on by next ON signal (L→H).
- (2) Normal operation: IGBT turns on and outputs current.
- (3) V_D level drops to under voltage trip level (UV_{DT}).
- (4) All low-side IGBTs turn OFF regardless of control input condition.
- (5) F_O output time (t_{FO})=minimum 20 μ s, and F_O stays low as long as V_D is below UV_{DR} .
- (6) V_D level reaches UV_{DR} .
- (7) Normal operation: IGBT turns on and outputs current.

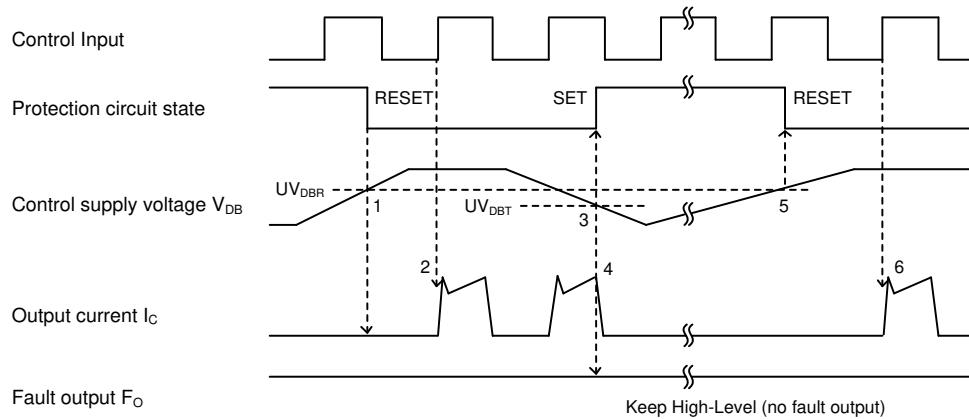

Figure 8. Under-Voltage Protection (High-side, UV_{DB})

- (1) Control supply voltage V_{DB} rises. After the voltage reaches under voltage reset level UV_{DBR} , IGBT turns on by next ON signal (L→H).
- (2) Normal operation: IGBT turns on and outputs current.
- (3) V_{DB} level drops to under voltage trip level (UV_{DBT}).
- (4) All high-side IGBTs turn OFF regardless of control input condition, but there is no F_o signal output.
- (5) V_{DB} level reaches UV_{DBR} .
- (6) Normal operation: IGBT turns on and outputs current.

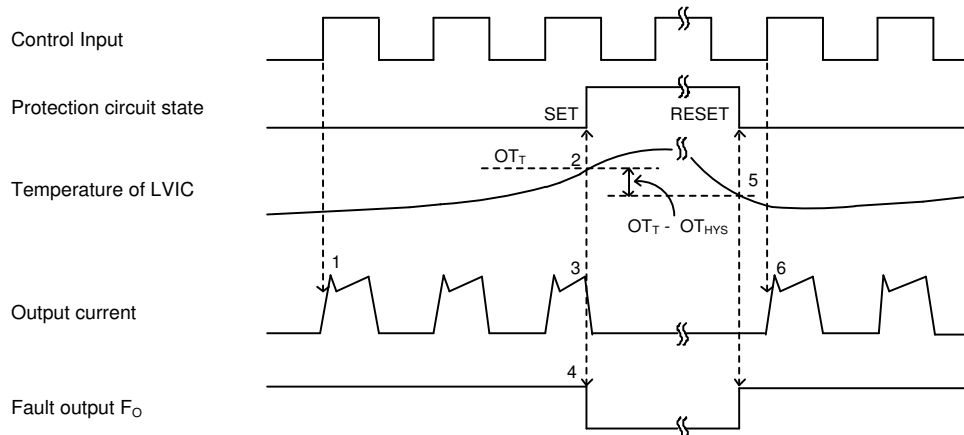
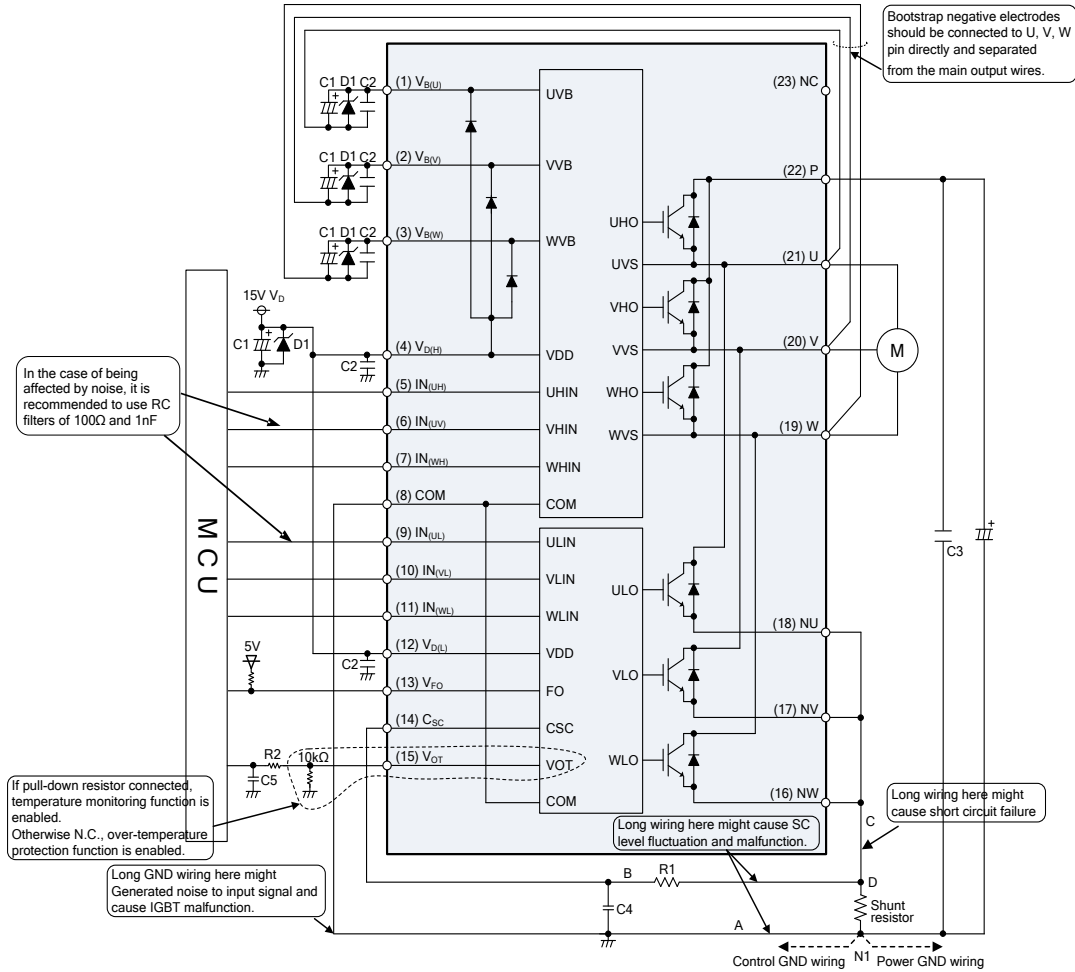

Figure 9. Over-Temperature Protection (Low-side, Detecting LVIC Temperature)

- (1) Normal operation: IGBT turns on and outputs current.
- (2) LVIC temperature exceeds over-temperature trip level (OT_T).
- (3) All low-side IGBTs turn off regardless of control input condition.
- (4) F_o output time (t_{FO})=minimum $20\mu s$, and F_o stays low as long as LVIC temperature is over OT_T .
- (5) LVIC temperature drops to over-temperature reset level ($OT_T - OT_{HYS}$).
- (6) Normal operation: IGBT turns on by the next ON signal (L→H).

Example of Application Circuit



- (1) If the control GND is connected with the power GND by common broad pattern, it may cause malfunction by power GND fluctuation. It is recommended to connect the control GND and power GND at a single point (N1), near the terminal of the shunt resistor.
- (2) A zener diode D1 (24V/1W) is recommended between each pair of control supply pins to prevent surge destruction.
- (3) Prevention of surge destruction can further be improved by placing the bus capacitor as close to pin P and N1 as possible. Generally a 0.1-0.22μF snubber capacitor C3 between the P-N1 terminals is recommended.
- (4) Selection of the R1*C4 filter components for short-circuit protection is recommended to have tight tolerance, and is temperature-compensated type. The R1*C4 time constant should be set such that SC current is shut down within 2μs; (typically 1.5-2μs). R1 and C4 should be placed as close as possible to the C_{SC} pin. SC interrupting time may vary with layout patterns and components selection, therefore thorough evaluation in the system is necessary.
- (5) Tight tolerance and temperature-compensated components are also recommended when selecting the R2*C5 filter for V_{OT}. The R2*C5 time constant should be set such that V_{OT} is immune to noise. Recommended values of R2 and C5 are 2kΩ and 10nF.
- (6) To prevent malfunction, traces A, B, and C should be as short as possible.
- (7) It is recommended that all capacitors are mounted as close to the IPM as possible. (C1: electrolytic type with good temperature and frequency characteristics. C2: ceramic type with 0.1-2μF, good temperature, frequency and DC bias characteristics.)
- (8) Input drives are active-high. There is a minimum 3.5kΩ pull-down resistor in the input circuit of IC. To prevent malfunction, the layout to each input should be as short as possible. When using RC coupling circuit, make sure the input signal levels meet the required turn-on and turn-off threshold voltages.
- (9) V_{FO} output is open drain type. It should be pulled up to MCU or control power supply (max= 5±0.5V), limiting the current (I_{FO}) to no more than 1mA. I_{FO} is estimated roughly by the formula of control power supply voltage divided by pull-up resistor. For example, if control supply is 5V, a 10kΩ (over 5kΩ) pull-up resistor is recommended.
- (10) Direct drive of the IPM from the MCU is possible without having to use opto-coupler or isolation transformer.
- (11) The IPM may malfunction and erroneous operations may occur if high frequency noise is superimposed to the supply line. To avoid such problems, line ripple voltage is recommended to have dV/dt ≤ ±1V/μs, and V_{ripple} ≤ 2Vp-p.
- (12) It is not recommended to use the IPM to drive the same load in parallel with another IPM or inverter types.

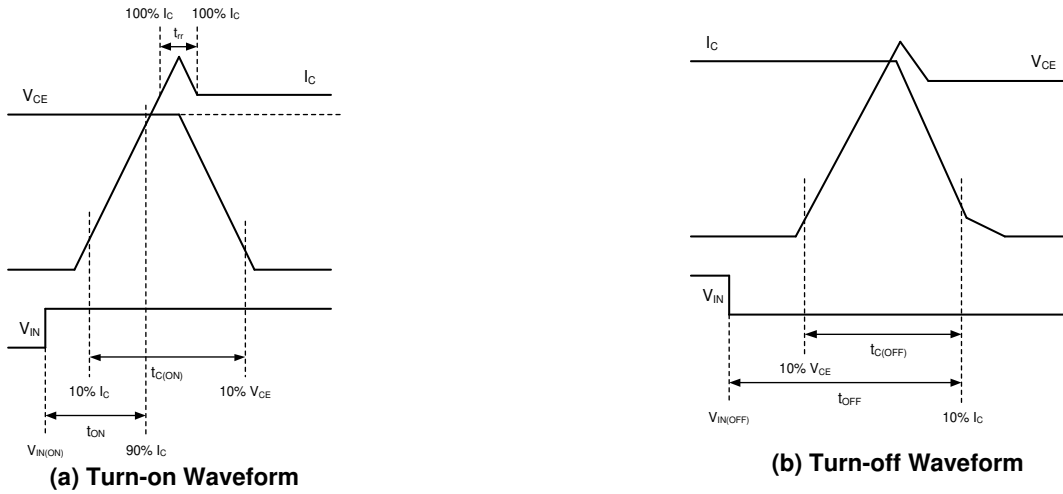
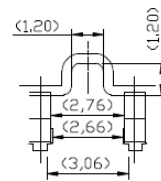
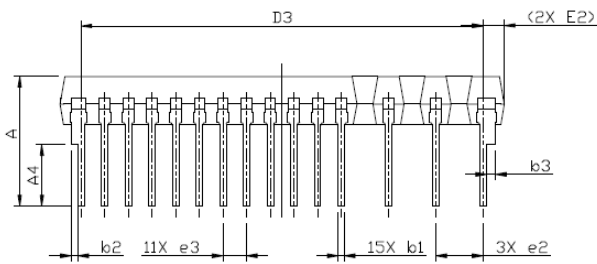
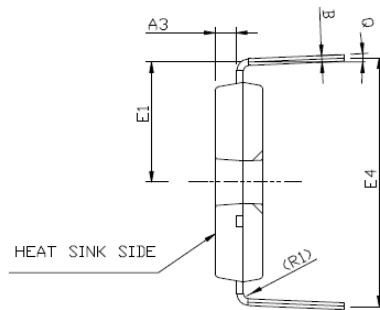
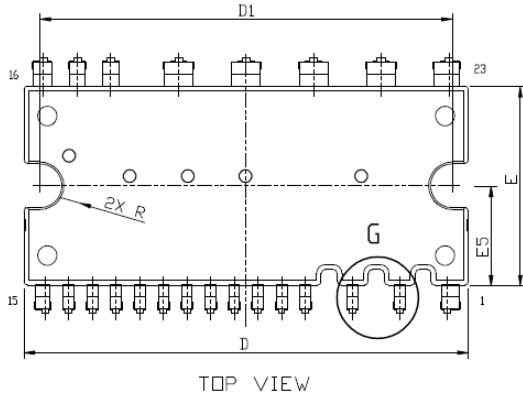
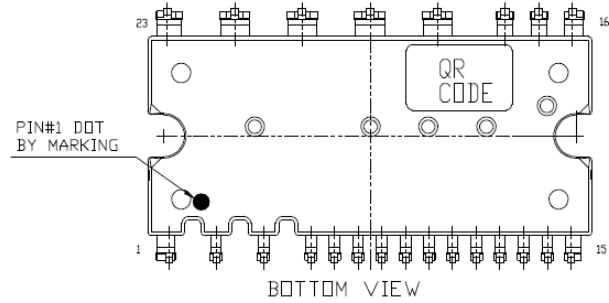
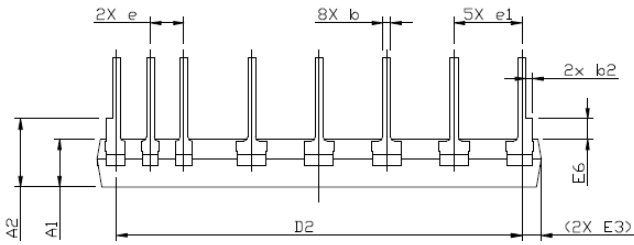
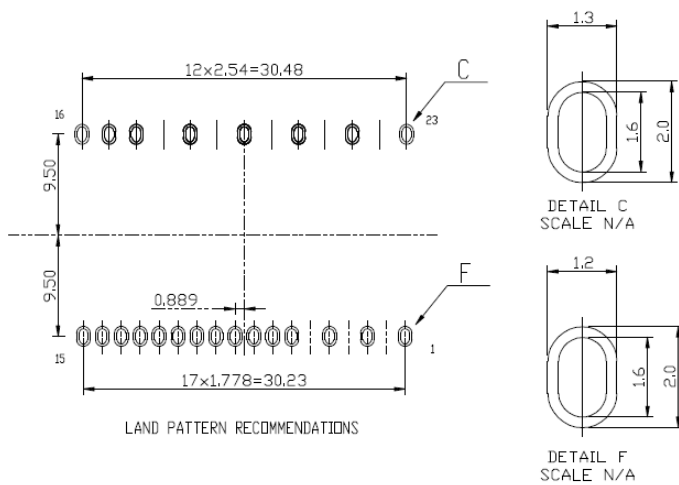

Figure 10. Switching Times Definition

Package Dimensions, IPM-5



DETAIL G
SCALE 5 : 1



DETAIL C
SCALE N/A

DETAIL F
SCALE N/A

UNIT: mm

- NOTE
- A) PACKAGE BODY SIZES EXCLUDE MOLD FLASH AND GATE BURRS. MOLD FLASH SHOULD BE LESS THAN 6 MIL.
 - B) TOLERANCE 0.100 MILLIMETERS UNLESS OTHERWISE SPECIFIED.
 - C) CONTROLLING DIMENSION IS MILLIMETER.
 - D) CONVERTED INCH DIMENSIONS ARE NOT NECESSARILY EXACT.
 - E) () IS REFERENCE

SYMBOLS	DIMENSIONS IN MILLIMETERS			DIMENSIONS IN INCHES		
	MIN	NOM	MAX	MIN	NOM	MAX
A	9.30	9.70	10.10	0.366	0.382	0.398
A1	3.30	3.60	3.90	0.130	0.142	0.154
A2	4.70	5.10	5.50	0.185	0.201	0.217
A3	1.50	1.60	1.70	0.059	0.063	0.067
A4	4.20	4.60	5.00	0.165	0.181	0.197
B	0.40	0.50	0.60	0.016	0.020	0.024
b	0.50	0.60	0.70	0.020	0.024	0.028
b1	0.40	0.50	0.60	0.016	0.020	0.024
b2	0.40	0.50	0.60	0.016	0.020	0.024
b3	0.60	0.70	0.80	0.024	0.028	0.032
D	33.10	33.40	33.70	1.303	1.315	1.327
D1	30.80	31.00	31.20	1.213	1.220	1.228
D2	30.18	30.48	30.78	1.188	1.200	1.212
D3	29.93	30.23	30.53	1.178	1.190	1.202
E	14.70	15.00	15.30	0.579	0.591	0.602
E1	8.60	9.00	9.40	0.339	0.354	0.370
E2	1.60 REF			0.063 REF		
E3	1.50 REF			0.059 REF		
E4	18.30	18.70	19.10	0.720	0.736	0.752
E5	7.30	7.50	7.70	0.287	0.295	0.303
E6	1.10	1.50	1.90	0.043	0.059	0.075
e	2.34	2.54	2.74	0.092	0.101	0.108
e1	4.88	5.08	5.28	0.192	0.200	0.208
e2	3.56	3.56	3.76	0.132	0.140	0.148
e3	1.578	1.778	1.978	0.062	0.070	0.078
R	1.50	1.60	1.70	0.059	0.063	0.067
R1	0.40 REF			0.016 REF		
Q	2°-6°			2°-6°		

Package Dimensions, IPM-5A

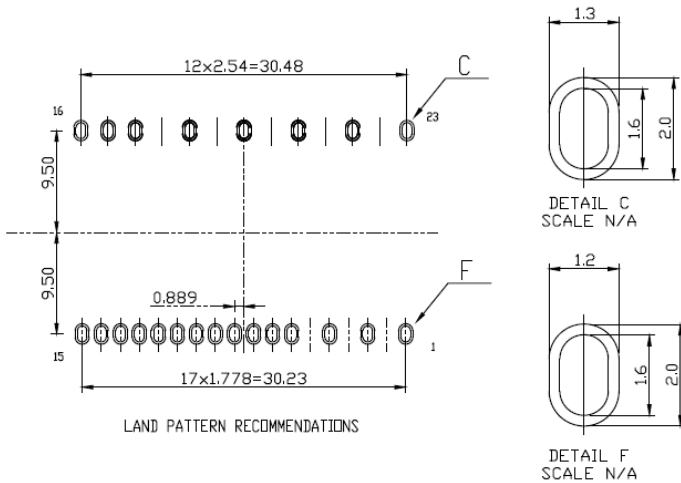
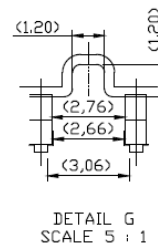
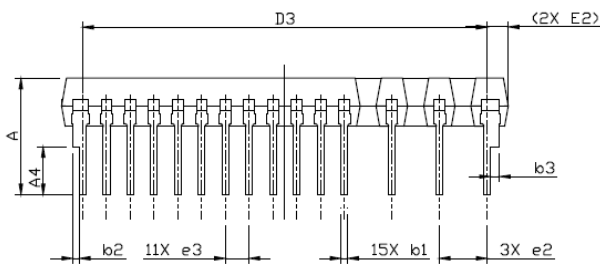
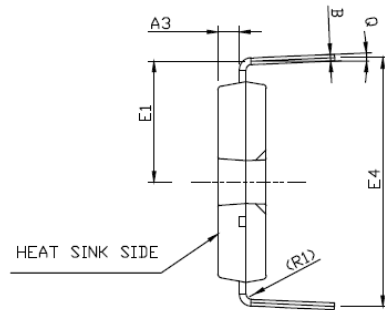
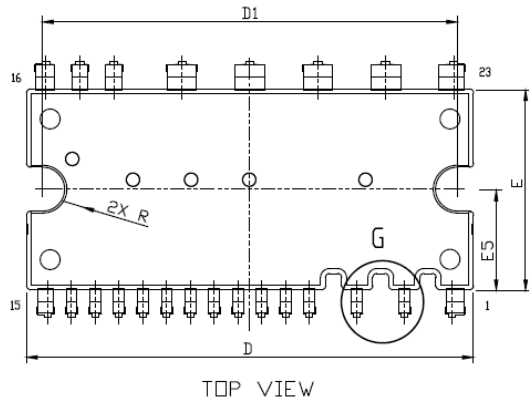
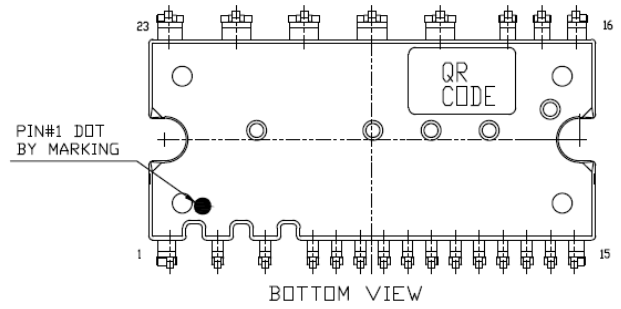
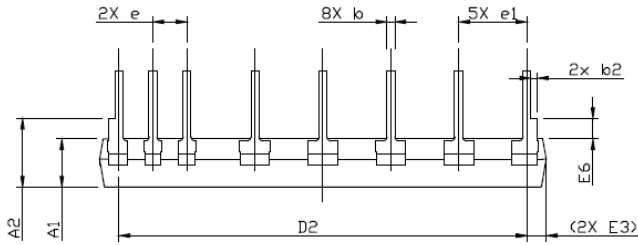

DETAIL C
SCALE N/A

DETAIL F
SCALE N/A

UNIT: mm

NOTE
A) PACKAGE BODY SIZES EXCLUDE MOLD FLASH AND GATE BURRS. MOLD FLASH SHOULD BE LESS THAN 6 MIL.
B) TOLERANCE 0.100 MILLIMETERS UNLESS OTHERWISE SPECIFIED.
C) CONTROLLING DIMENSION IS MILLIMETER.
CONVERTED INCH DIMENSIONS ARE NOT NECESSARILY EXACT.
D) < > IS FOR REFERENCE

SYMBOLS	DIMENSIONS IN MILLIMETERS			DIMENSIONS IN INCHES		
	MIN	NOM	MAX	MIN	NOM	MAX
A	8.30	8.70	9.10	0.326	0.342	0.358
A1	3.30	3.60	3.90	0.130	0.142	0.154
A2	4.70	5.10	5.50	0.185	0.201	0.217
A3	1.50	1.60	1.70	0.059	0.063	0.067
A4	3.20	3.60	4.00	0.125	0.141	0.157
B	0.40	0.50	0.60	0.016	0.020	0.024
b	0.50	0.60	0.70	0.020	0.024	0.028
b1	0.40	0.50	0.60	0.016	0.020	0.024
b2	0.40	0.50	0.60	0.016	0.020	0.024
b3	0.60	0.70	0.80	0.024	0.028	0.032
D	33.10	33.40	33.70	1.303	1.315	1.327
D1	30.80	31.00	31.20	1.213	1.220	1.228
D2	30.18	30.48	30.78	1.188	1.200	1.212
D3	29.93	30.23	30.53	1.178	1.190	1.202
E	14.70	15.00	15.30	0.579	0.591	0.602
E1	8.60	9.00	9.40	0.339	0.354	0.370
E2	1.60 REF			0.063 REF		
E3	1.50 REF			0.059 REF		
E4	18.20	18.60	19.00	0.716	0.732	0.748
E5	7.30	7.50	7.70	0.287	0.295	0.303
E6	1.10	1.50	1.90	0.043	0.059	0.075
e	2.34	2.54	2.74	0.092	0.101	0.108
e1	4.88	5.08	5.28	0.192	0.200	0.208
e2	3.356	3.556	3.756	0.132	0.140	0.148
e3	1.578	1.778	1.978	0.062	0.070	0.078
R	1.50	1.60	1.70	0.059	0.063	0.067
R1	0.40 REF			0.016 REF		
Q	2°-6°			2°-6°		

LEGAL DISCLAIMER

Applications or uses as critical components in life support devices or systems are not authorized. AOS does not assume any liability arising out of such applications or uses of its products. AOS reserves the right to make changes to product specifications without notice. It is the responsibility of the customer to evaluate suitability of the product for their intended application. Customer shall comply with applicable legal requirements, including all applicable export control rules, regulations and limitations.

AOS' products are provided subject to AOS' terms and conditions of sale which are set forth at:

http://www.aosmd.com/terms_and_conditions_of_sale

LIFE SUPPORT POLICY

ALPHA AND OMEGA SEMICONDUCTOR PRODUCTS ARE NOT AUTHORIZED FOR USE AS CRITICAL COMPONENTS IN LIFE SUPPORT DEVICES OR SYSTEMS

As used herein:

1. Life support devices or systems are devices or systems which, (a) are intended for surgical implant into the body or (b) support or sustain life, and (c) whose failure to perform when properly used in accordance with instructions for use provided in the labeling, can be reasonably expected to result in a significant injury of the user.
2. A critical component in any component of a life support, device, or system whose failure to perform can be reasonably expected to cause the failure of the life support device or system, or to affect its safety or effectiveness.