



Spread Spectrum Frequency Timing Generator

Features

- Maximized EMI suppression using Cypress's Spread Spectrum technology
- Generates a spread spectrum copy of the provided input
- Integrated loop filter components
- Operates with a 3.3V or 5V supply
- Low-power CMOS design
- Available in 8-pin SOIC (Small Outline Integrated Circuit)

Overview

The W42C31-09 incorporates the latest advances in PLL spread spectrum frequency synthesizer techniques. By frequency modulating the output with a low-frequency carrier, EMI is greatly reduced. Use of this technology allows systems

to pass increasingly difficult EMI testing without resorting to costly shielding or redesign.

In a system, not only is EMI reduced in the various clock lines, but also in all signals which are synchronized to the clock. Therefore, the benefits of using this technology increase with the number of address and data lines in the system. The Simplified Block Diagram shows a simple implementation.

Table 1. Frequency Spread Selection

W42C31-09		Input Frequency (MHz)	Output Frequency (MHz)
FS1	FS0		
0	0	30 to 55	$f_{IN} \pm 0.625\%$
0	1	30 to 55	$f_{IN} \pm 1.25\%$
1	0	30 to 55	$f_{IN} \pm 2.5\%$
1	1	30 to 55	$f_{IN} \pm 3.75\%$

Simplified Block Diagram

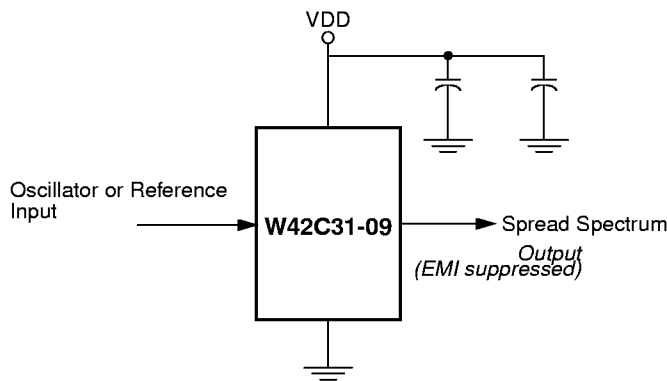

Pin Configuration

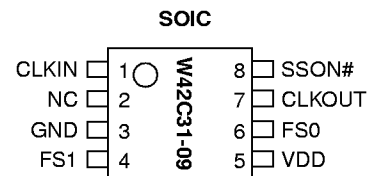

Pin Definitions

Pin Name	Pin No.	Pin Type	Pin Description
CLKOUT	7	O	Output Modulated Frequency: Frequency modulated copy of the unmodulated input clock
CLKIN	1	I	External Reference Frequency Input
NC	2	I	No Connect: This pin must be left unconnected.
SSON#	8	I	Spread Spectrum Control (Active LOW): Pulling this input signal LOW turns the internal modulation waveform on. This pin has an internal pull-down resistor.
FS0:1	6, 4	I	Frequency Selection Bit 0: These pins select the frequency spreading characteristics. Refer to <i>Table 1</i> . These pins have internal pull-up resistors.
VDD	5	P	Power Connection: Connected to 3.3V or 5V power supply.
GND	3	G	Ground Connection: This should be connected to the common ground plane.

Functional Description

The W42C31-09 uses a phase locked loop (PLL) to frequency modulate an input clock. The result is an output clock whose frequency is slowly swept over a narrow band near the input signal. The basic circuit topology is shown in *Figure 1*. The input reference signal is divided by Q and fed to the phase detector. A signal from the VCO is divided by P and fed back to the phase detector also. The PLL will force the frequency of the VCO output signal to change until the divided output signal and the divided reference signal match at the phase detector input. The output frequency is then equal to the ratio of P/Q times the reference frequency. (Note: For the W42C31-09 the output frequency is equal to the input frequency.) The unique feature of the Spread Spectrum Frequency Timing Generator is that a modulating waveform is superimposed at the input to the VCO. This causes the VCO output to be slowly swept across a predetermined frequency band.

Because the modulating frequency is typically 1000 times slower than the fundamental clock, the spread spectrum process has little impact on system performance.

Frequency Selection With SSFTG

In Spread Spectrum Frequency Timing Generation, EMI reduction depends on the shape, modulation percentage, and frequency of the modulating waveform. While the shape and frequency of the modulating waveform are fixed, the modulation percentage may be varied.

Using frequency select bits (FS1:0 pins), various spreading percentages can be chosen (see *Table 1*).

A larger spreading percentage improves EMI reduction. However, large spread percentages may either exceed system maximum frequency ratings or lower the average frequency to a point where performance is affected. For these reasons, spreading percentages between $\pm 0.5\%$ and $\pm 2.5\%$ are most common.

The W42C31 features the ability to select from various spread spectrum characteristics. Selections specific to the W42C31-09 are shown in *Table 1*. Other spreading characteristics are available (see separate data sheets) or can be created with a custom mask. Also, other devices in the W42C31 family offer frequency multiplication in addition to the spread spectrum function. This will allow the use of less expensive fundamental mode crystals.

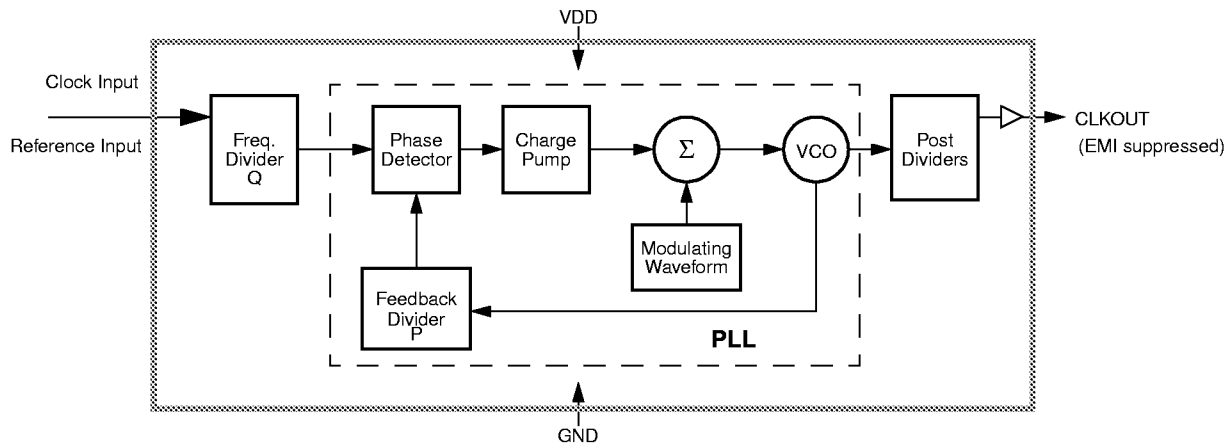

Figure 1. System Block Diagram (Concept, not actual implementation)

Spread Spectrum Frequency Timing Generation

The benefits of using Spread Spectrum Frequency Timing Generation are depicted in *Figure 2*. An EMI emission profile of a clock harmonic is shown.

Contrast the typical clock EMI with the Cypress Spread Spectrum Frequency Timing Generation EMI. Notice the spike in the typical clock. This spike can make systems fail quasi-peak EMI testing. The FCC and other regulatory agencies test for peak emissions. With spread spectrum enabled, the peak energy is much lower (at least 8 dB) because the energy is spread out across a wider bandwidth.

Modulating Waveform

The shape of the modulating waveform is critical to EMI reduction. The modulation scheme used to accomplish the maximum reduction in EMI is shown in *Figure 3*. The period of the modulation is shown as a percentage of the period length along the X axis. The amount that the frequency is varied is shown along the Y axis, also shown as a percentage of the total frequency spread.

Cypress frequency selection tables express the modulation percentage in two ways. The first method displays the spreading frequency band as a percent of the programmed average output frequency, symmetric about the programmed average frequency. This method is always shown using the expression $f_{\text{Center}} \pm X_{\text{MOD}}\%$ in the frequency spread selection table.

The second approach is to specify the maximum operating frequency and the spreading band as a percentage of this frequency. The output signal is swept from the lower edge of the band to the maximum frequency. The expression for this approach is $f_{\text{MAX}} - X_{\text{MOD}}\%$. Whenever this expression is used, Cypress has taken care to ensure that f_{MAX} will never be exceeded. This is important in applications where the clock drives components with tight maximum clock speed specifications.

SSON# Pin

An internal pull-down resistor defaults the chip into a spread spectrum mode. The SSON# pin enables the spreading feature when set LOW. The SSON# pin disables the spreading feature when set HIGH (V_{DD}).

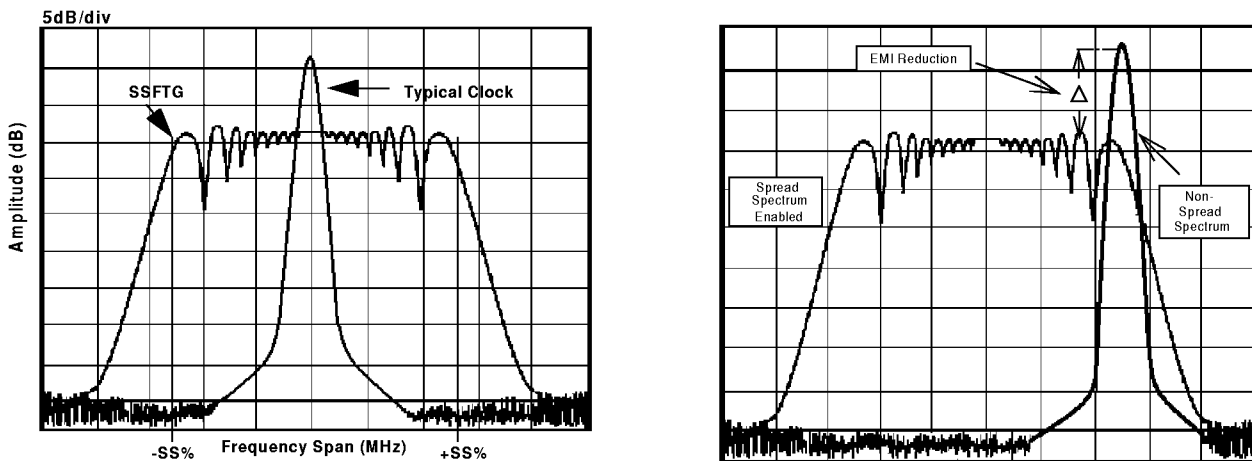

Figure 2. Typical Clock and SSFTG Comparison

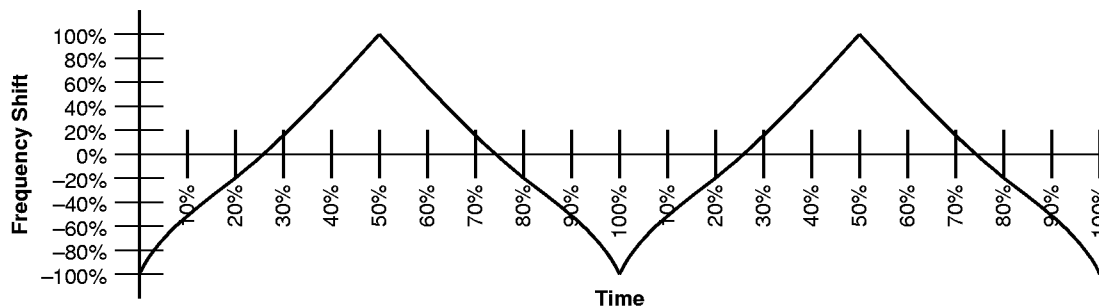

Figure 3. Modulation Waveform Profile

Absolute Maximum Ratings

Stresses greater than those listed in this table may cause permanent damage to the device. These represent a stress rating only. Operation of the device at these or any other conditions

above those specified in the operating sections of this specification is not implied. Maximum conditions for extended periods may affect reliability

Parameter	Description	Rating	Unit
V_{DD}, V_{IN}	Voltage on any pin with respect to GND	-0.5 to +7.0	V
T_{STG}	Storage Temperature	-65 to +150	°C
T_A	Operating Temperature	0 to +70	°C
T_B	Ambient Temperature under Bias	-55 to +125	°C
P_D	Power Dissipation	0.5	W

DC Electrical Characteristics: $0^{\circ}\text{C} < T_A < 70^{\circ}\text{C}$, $V_{DD} = 3.3\text{V} \pm 10\%$

Parameter	Description	Test Condition	Min	Typ	Max	Unit
I_{DD}	Supply Current			18	32	mA
t_{ON}	Power Up Time	First locked clock cycle after Power Good			5	ms
V_{IL} (Logic Inputs)	Input Low Voltage				0.8	V
V_{IL} (CLKIN)	Input Low Voltage			.4	.5	V
V_{IH} (Logic Inputs)	Input High Voltage		2.4			V
V_{IH} (CLKIN)	Input High Voltage		2.8	2.6		V
V_{OL}	Output Low Voltage				0.4	V
V_{OH}	Output High Voltage		2.5			V
I_{IL}	Input Low Current	Note 1			-100	μA
I_{IH}	Input High Current	Note 1			10	μA
I_{OL}	Output Low Current	@ 0.4V, $V_{DD} = 3.3\text{V}$		15		mA
I_{OH}	Output High Current	@ 2.4V, $V_{DD} = 3.3\text{V}$		15		mA
C_I	Input Capacitance	All pins except CLKIN			7	pF
C_I	Input Capacitance	CLKIN pin only		6	10	pF
R_P	Input Pull-Up Resistor			500		$\text{k}\Omega$
Z_{OUT}	Clock Output Impedance			25		Ω

Note:

- Inputs FS1:0 have a pull-up resistor, Input SSON# has a pull-down resistor.

DC Electrical Characteristics: $0^{\circ}\text{C} < T_A < 70^{\circ}\text{C}$, $V_{DD} = 5\text{V} \pm 10\%$

Parameter	Description	Test Condition	Min	Typ	Max	Unit
I_{DD}	Supply Current			30	45	mA
t_{ON}	Power Up Time	First locked clock cycle after Power Good			5	ms
V_{IL} (Logic Inputs)	Input Low Voltage				$0.15V_{DD}$	V
V_{IL} (CLKIN)	Input Low Voltage				0.4	V
V_{IH} (Logic Inputs)	Input High Voltage		$0.7V_{DD}$			V
V_{IH} (CLKIN)	Input High Voltage		4.2	3.8		V
V_{OL}	Output Low Voltage				0.4	V
V_{OH}	Output High Voltage		2.5			V
I_{IL}	Input Low Current	Note 1			-100	μA
I_{IH}	Input High Current	Note 1			10	μA
I_{OL}	Output Low Current	@ 0.4V, $V_{DD} = 5\text{V}$		24		mA
I_{OH}	Output High Current	@ 2.4V, $V_{DD} = 5\text{V}$		24		mA
C_I	Input Capacitance	All pins except CLKIN			7	pF
C_I	Input Capacitance	CLKIN pin only		6	10	pF
R_P	Input Pull-Up Resistor			500		$\text{k}\Omega$
Z_{OUT}	Clock Output Impedance			25		Ω

AC Electrical Characteristics: $T_A = 0^{\circ}\text{C}$ to $+70^{\circ}\text{C}$, $V_{DD} = 3.3\text{V} \pm 10\%$

Symbol	Parameter	Test Condition	Min	Typ	Max	Unit
f_{IN}	Input Frequency	Input Clock	30	40	55	MHz
f_{OUT}	Output Frequency	Spread Off	30	40	55	MHz
t_R	Output Rise Time	V, 15-pF load 0.8–2.4		2	5	ns
t_F	Output Fall Time	V, 15-pF load 2.4–0.8		2	5	ns
t_{OD}	Output Duty Cycle	15-pF load	40		60	%
t_{ID}	Input Duty Cycle		40		60	%
t_{JCYC}	Jitter, Cycle-to-Cycle			250	300	ps
	Harmonic Reduction	$f_{out} = 40$ MHz, third harmonic measured, reference board, 15-pF load	8			dB

AC Electrical Characteristics: $T_A = 0^{\circ}\text{C}$ to $+70^{\circ}\text{C}$, $V_{DD} = 5\text{V} \pm 10\%$

Symbol	Parameter	Test Condition	Min	Typ	Max	Unit
f_{IN}	Input Frequency	Input Clock	30	40	55	MHz
f_{OUT}	Output Frequency	Spread Off	30	40	55	MHz
t_R	Output Rise Time	V, 15-pF load 0.8–2.4		2	5	ns
t_F	Output Fall Time	V, 15-pF load 2.4–0.8		2	5	ns
t_{OD}	Output Duty Cycle	15-pF load	40		60	%
t_{ID}	Input Duty Cycle		40		60	%
t_{JCYC}	Jitter, Cycle-to-Cycle			250	300	ps
	Harmonic Reduction	$f_{out} = 40$ MHz, third harmonic measured, reference board, 15-pF load	8			dB

Application Information

Recommended Circuit Configuration

For optimum performance in system applications the power supply decoupling scheme shown in *Figure 4* should be used.

V_{DD} decoupling is important to both reduce phase jitter and EMI radiation. The 0.1- μ F decoupling capacitor should be placed as close to the V_{DD} pin as possible, otherwise the in-

creased trace inductance will negate its decoupling capability. The 10- μ F decoupling capacitor shown should be a tantalum type. For further EMI protection, the V_{DD} connection can be made via a ferrite bead, as shown.

Recommended Board Layout

Figure 5 shows a recommended 2-layer board layout.

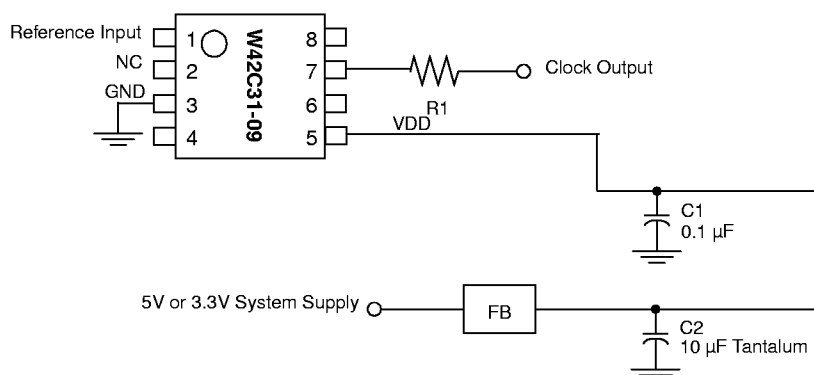



Figure 4. Recommended Circuit Configuration

- C1 = High frequency supply decoupling capacitor (0.1- μ F recommended).
- C2 = Common supply low frequency decoupling capacitor (10- μ F tantalum recommended).
- R1 = Match value to line impedance
-  = Ferrite Bead
-  = Via To GND Plane

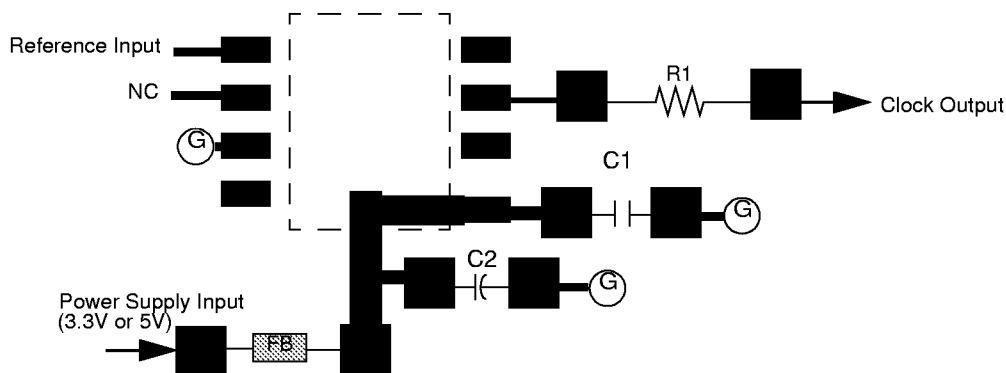
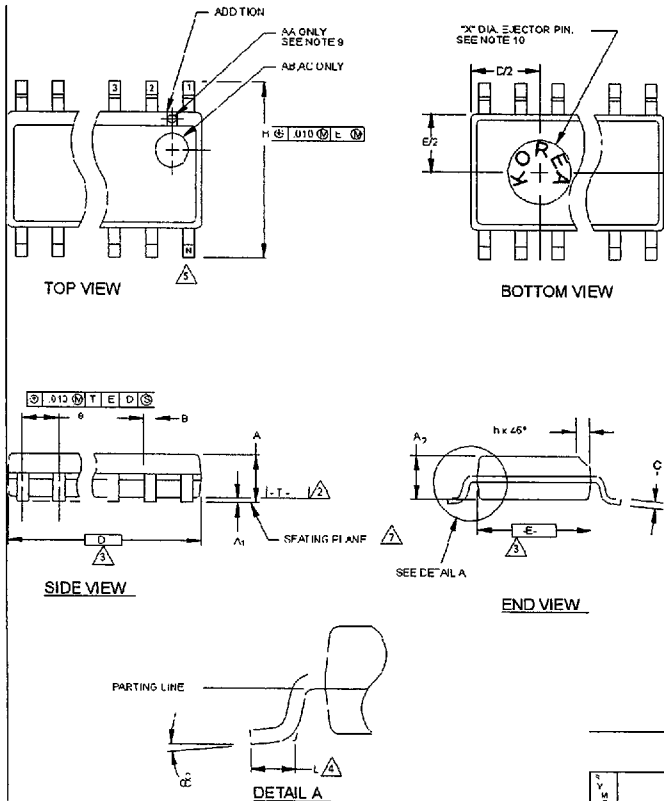

Figure 5. Recommended Board Layout (2-Layer Board)

Ordering Information

Ordering Code	Freq. Mask Code	Package Name	Package Type
W42C31	09	G	8-pin Plastic SOIC (150-mil)

Document #: 38-00799-A

Package Diagram
8-Pin Small Outline Integrated Circuit (SOIC, 150-mil)

NOTES:

1. MAXIMUM DIE THICKNESS ALLOWABLE IS .015.
2. DIMENSIONING & TOLERANCES PER ANSI Y14.5M - 1982.
3. "T" IS A REFERENCE DATUM.
4. "D" & "E" ARE REFERENCE DATUMS AND DO NOT INCLUDE MOLD FLASH OR PROTRUSIONS, BUT DOES INCLUDE MOLD MISMATCH AND ARE MEASURED AT THE MOLD PARTING LINE. MOLD FLASH OR PROTRUSIONS SHALL NOT EXCEED 0.006 INCHES PER SIDE.
5. "L" IS THE LENGTH OF TERMINAL FOR SOLDERING TO A SUBSTRATE.
6. "N" IS THE NUMBER OF TERMINAL POSITIONS.
7. TERMINAL POSITIONS ARE SHOWN FOR REFERENCE ONLY.
8. FORMED LEADS SHALL BE PLANAR WITH RESPECT TO ONE ANOTHER WITHIN .003 INCHES AT SEATING PLANE.
9. THE APPEARANCE OF PIN #1 I.D. ON THE 8 LD IS OPTIONAL, ROUND TYPE ON SINGLE LEADFRAME AND RECTANGULAR TYPE ON MATRIX LEADFRAME.
10. COUNTRY OF ORIGIN LOCATION AND EJECTOR PIN ON PACKAGE BOTTOM IS OPTIONAL AND DEPEND ON ASSEMBLY LOCATION.
11. CONTROLLING DIMENSION: INCHES.

THIS TABLE IN INCHES

DIM.	COMMON DIMENSIONS			NOTE VARIATIONS	3 D			5 N
	MIN.	NOM.	MAX.		MIN.	NOM.	MAX.	
A	.061	.064	.068	AA	.189	.194	.196	8
A ₁	.004	.006	.0098	AB	.337	.342	.344	14
A ₂	.055	.058	.061	AC	.366	.391	.393	16
B	.0138	.016	.0192					
C	.0075	.008	.0098					
D	SEE VARIATIONS			3				
E	.150	.155	.157					
e	.050 BSC							
H	.230	.236	.244					
h	.010	.013	.016					
L	.016	.025	.035					
N	SEE VARIATIONS			5				
α	0° 5° 8°							
X	.085	.093	.100					

THIS TABLE IN MILLIMETERS

DIM.	COMMON DIMENSIONS			NOTE VARIATIONS	3 D			5 N
	MIN.	NOM.	MAX.		MIN.	NOM.	MAX.	
A	1.55	1.63	1.73	AA	4.80	4.93	4.98	8
A ₁	0.127	0.15	0.25	AB	8.58	8.69	8.74	14
A ₂	1.40	1.47	1.55	AC	9.80	9.93	9.96	16
B	0.35	0.41	0.49					
C	0.19	0.20	0.25					
D	SEE VARIATIONS			3				
E	3.81	3.94	3.99					
e	1.27 BSC							
H	5.84	5.99	6.20					
h	0.25	0.33	0.41					
L	0.41	0.64	0.89					
N	SEE VARIATIONS			5				
α	0° 5° 8°							
X	2.16	2.36	2.54					