

PART NUMBER	REV	FIRST USED
680009-1	A	854400-1
680009-2	A	565435-5

PRELIMINARY

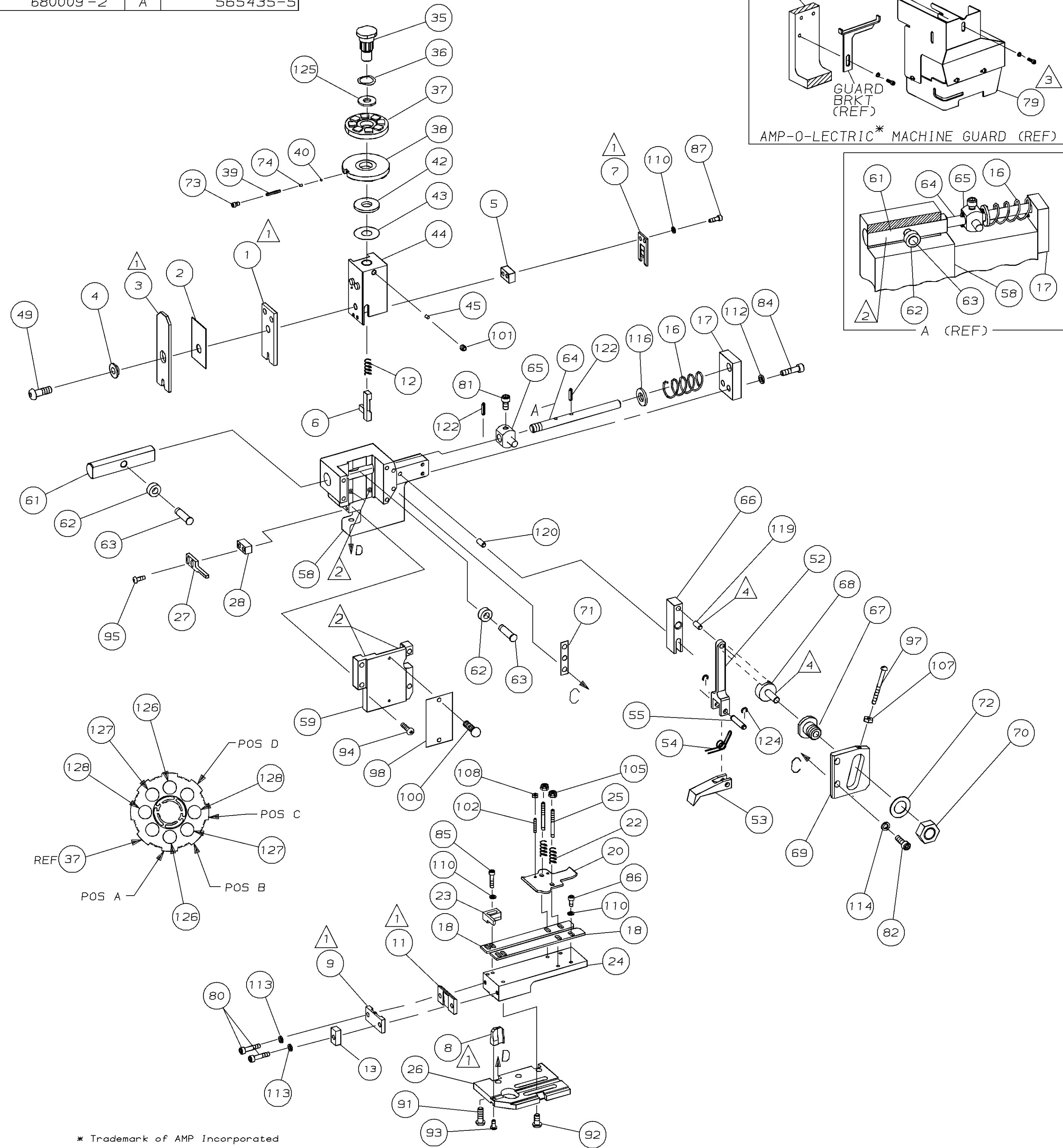
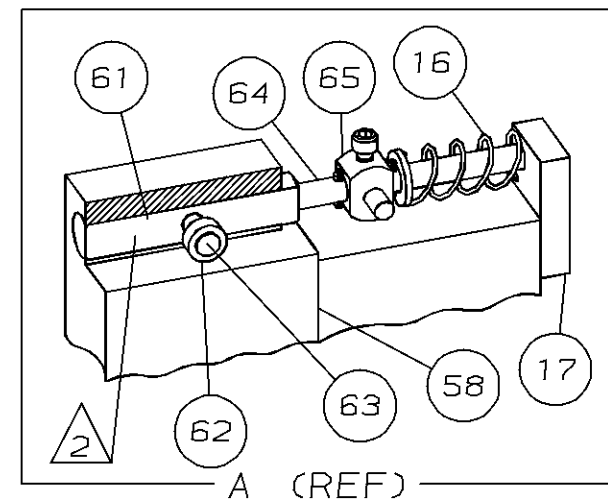
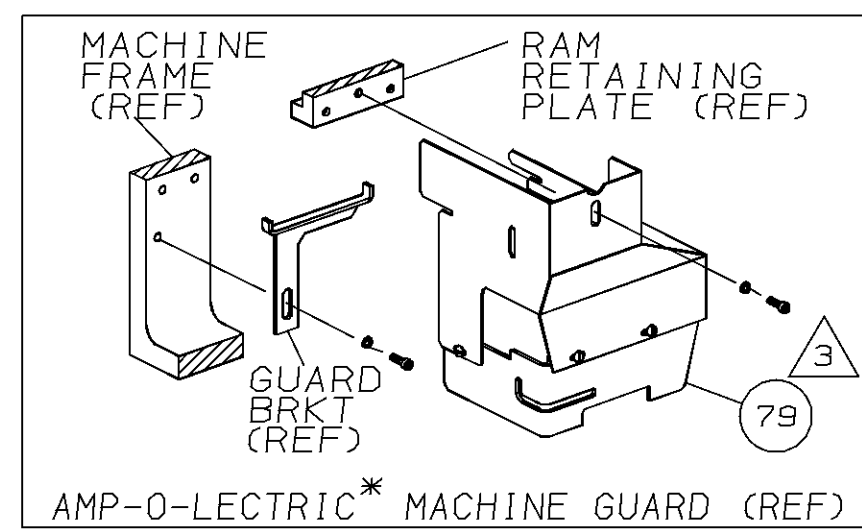

* Trademark of AMP Incorporated

POST-FEED 1 5/8 STROKE

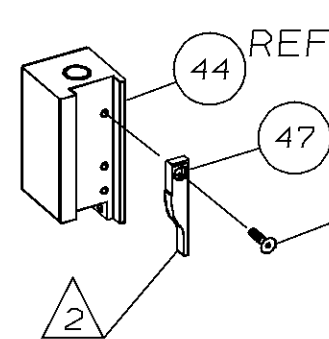

POST-FEED 1 1/8 STROKE

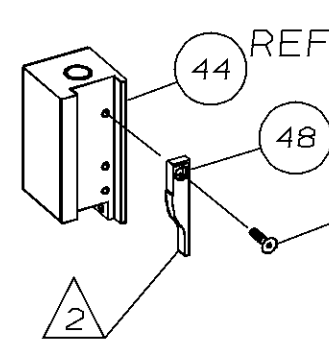

- 1 RECOMMENDED SPARE PARTS.
 - 2 GREASE LIGHTLY.
 - 3 GUARD MUST BE IN PLACE WHEN OPERATING APPLICATOR IN AMP-O-LECTRIC MACHINE.
 - 4 LUBRICATE DAILY USING NO. 20 MACHINE OIL.
5. ITEMS WITH QTY OF REF SPECIFIED (EXCEPT ITEM 79) ARE USED ON ITEM 32.

TERMINAL NAME:
.205 FASTON RECEPTACLE

TERM	APPL	SPEC	114-2036
170181-1			
170181-2			
170181-3			
170181-4			

CRIMPING DATA

PAD LTR	CRIMP HEIGHT	WIRE SIZE		
A	.055 ±.002	0.75mm ²		
B	.051 ±.002	0.50mm ² (20)		
C	.048 ±.002	0.30mm ² (22)		
D	NOT USED			
CRIMP	SIZE	TYPE	RANGE	
WIRE	.090	F	0.3-0.75mm ²	
INSUL	FEED	APPL INST	SET UP GAGE	LAYOUT
.140	.685	AI 8039	458638-1	15
WIRE STRIP LENGTH		-		

QTY	REV	U/M	DWG SIZE	PART NO	DESCRIPTION	ITEM NO
2	2	-	C	2-354779-6	PIN, WIRE DISC (.3120)C	128
2	2	-	C	2-354779-0	PIN, WIRE DISC (.3090)B	127
2	2	-	C	1-354779-2	PIN, WIRE DISC (.3050)A	126
1	1	-	A	986950-1	WASHER, FLAT PRECISION	125
REF	REF	-	A	21045-3	RING, RET "C" (Ø.187)FD PIN	124
REF	REF	-	A	5-21028-1	PIN, STD SPRING (Ø.12)FD ADJ ROD	122
REF	REF	-	A	1-21030-7	PIN, DOWEL (Ø.187x1.50)HSG	120
REF	REF	-	A	1-21030-1	PIN, DOWEL (Ø.187x.50)LEVER	119
REF	REF	-	A	21899-4	WASHER, FLAT (Ø5/16)SCR ADJ	116
REF	REF	-	A	21024-5	WASHER, LOCK (NO.10)FD ADJ PL	114
2	2	-	A	21024-5	WASHER, LOCK (NO.10)SHEAR PL	113
REF	REF	-	A	21024-5	WASHER, LOCK (NO.10)FD ROD GDE	112
7	7	-	A	21024-4	WASHER, LOCK (NO.8)SHEAR BL	110
2	2	-	A	21018-4	NUT, HEX (4-40)DRAG	108
REF	REF	-	A	21018-5	NUT, HEX (6-32)FD ADJ PL	107
2	2	-	A	21022-2	NUT, HEX SL (8-32)DRAG STUD	105
2	2	-	A	4-21078-8	SKT SKT SET (4-40x.75)DRAG	102
1	1	-	A	21009-2	SCR, SKT SET (1/4-20x.25)RAM	101
2	2	-	A	21017-2	SCR, DRIVE (#2x.19)ID PLATE	100
1	1	-	A	1-21002-7	SCR, BHC (6-32x.38)CAM	99
1	1	-	B	461264-1	PLATE, IDENTIFICATION	98
REF	REF	-	A	6-23715-5	SCR, PAN HD (6-32x1.50)FEED ADJ	97
2	2	-	A	2-21002-2	SCR, BHC (8-32x.50)STRIPPER	95
REF	REF	-	A	2-21002-9	SCR, BHC (10-32x.75)HSG CAP	94
1	1	-	A	22733-8	SCR, BHC (8-32x.38 LW)ANVIL	93
4	4	-	A	3-21002-3	SCR, BHC (1/4-20x.50)ST 6D PL	92
REF	REF	-	A	2-22733-8	SCR, BHC (1/4-20x.62)BASE PL	91
90						90
89						89
88						88
2	2	-	A	2-21000-6	SCR, SHC (8-32x.38)SLUG BLADE	87
3	3	-	A	7-21000-4	SCR, SHC (8-32x.31)STRIP GUIDE	86
2	2	-	A	2-21000-8	SCR, SHC (8-32x.62)R STRIP GUIDE	85
REF	REF	-	A	3-21000-7	SCR, SKT CAP (10-32x.75)FD GDE	84
REF	REF	-	A	3-21000-6	SCR, SKT CAP (10-32x.62)FD ADJ P	82
REF	REF	-	A	3-21000-4	SCR, SKT CAP (10-32x.38)PIVOT BL	81
2	2	-	A	3-21000-8	SCR, SKT CAP (10-32x.88)SH PL	80
REF	-	-	A	455745-1	GUARD, WINDOW	79
78						78
77						77
76						76
75						75
1	1	-	A	690603-1	SPRING, ASSIST	74
1	1	-	A	23030-1	SCR, SKT CAP (6-32x.25)CP DSC	73
REF	REF	-	A	458109-1	WASHER, FLAT (SPECIAL)	72
REF	REF	-	A	690517-1	SPACER	71

QTY	REV	U/M	DWG SIZE	PART NO	DESCRIPTION	ITEM NO
-1					LEADMAKER	
-2					AMP-O-LECTRIC	
REF	REF	-	A	22594-8	NUT, HEX	70
REF	REF	-	B	240628-1	PLATE, ADJ	69
REF	REF	-	B	240626-1	SHAFT, PIVOT	68
REF	REF	-	B	240633-1	BUSHING	67
REF	REF	-	A	455680-1	LEVER, INTERMEDIATE	66
REF	REF	-	B	240629-1	BLOCK, PIVOT	65
REF	REF	-	A	240632-2	SCR, ADJ	64
REF	REF	-	B	240659-3	PIN, CAM ROLLER	63
REF	REF	-	B	240658-1	CAM, ROLLER	62
REF	REF	-	B	454398-1	ROD, FEED	61
REF	REF	-	C	454220-1	CAP, RAM	59
REF	REF	-	D	453736-1	HOUSING	58
REF	REF	-	B	240624-1	PIN, FEED FINGER	55
REF	REF	-	B	691499-1	SPRING, FEED FINGER	54
REF	REF	-	B	240635-1	FINGER, FEED	53
REF	REF	-	B	240634-1	LEVER, TERMINAL	52
1	1	-	A	7-21002-9	BOLT, CRIMPER (5/16-24x1.00)	49
1	-	-	B	690501-3	CAM, POST FEED 1 1/8 ST	48
-	1	-	B	690501-4	CAM, POST-FEED 1 5/8 ST	47
1	1	-	A	690191-1	PLUG, NYLON	45
1	1	-	C	455674-1	RAM	44
1	1	-	A	690125-1	WASHER, LAMINATED	43
1	1	-	A	690124-1	WASHER, RAM	42
1	1	-	A	23241-6	BALL, STEEL	40
1	1	-	A	690170-1	SPRING, COMPRESSION	39
1	1	-	C	690142-1	DISC, INSULATION	38
1	1	-	D	354777-1	WIRE DISC, PLASTIC	37
1	1	-	A	22480-5	WASHER, SPRING	36
1	1	-	B	690212-1	POST, RAM	35
1	1	-	D	458980-1	APPLICATOR, BASIC (SUB ASSY)	32
1	1	-	B	3-690451-2	SPACER, STRIPPER	28
1	1	-	A	240639-1	STRIPPER	27
REF	REF	-	C	455676-1	PLATE, BASE	26
2	2	-	A	22354-8	DRAG, STUD	25
1	1	-	B	455678-1	PLATE, STRIP GUIDE	24
1	1	-	C	240825-3	PLATE, STRIP HOLD DOWN	23
2	2	-	A	4-22281-1	SPRING, DRAG	22
1	1	-	A	454177-1	DRAG, STOCK	20
2	2	-	C	454204-1	GUIDE, STRIP (FRONT)	18
REF	REF	-	A	454178-1	GUIDE, FEED ROD	17
REF	REF	-	A	4-22284-9	SPRING, FEED RETURN	16
1	1	-	C	690481-9	SPACER, HOLD DOWN	13
1	1	-	A	23846-1	SPRING, HOLD DOWN	12
1	1	-	B	240644-1	PLATE, REAR SHEAR	11
1	1	-	B	690495-3	PLATE, FRONT SHEAR	9
1	1	-	D	240693-5	ANVIL	8
1	1	-	B	690474-5	BLADE, SLUG	7
1	1	-	D	2-455892-2	HOLD DOWN, TERMINAL	6
1	1	-	C	3-240641-7	SPACER, SLUG BLADE	5
1	1	-	B	238009-1	SPACER, BLOCK CRIMPER	4
1	1	-	C	1-456134-4	CRIMPER, INSULATION	3
1	1	-	B	455888-7	SPACER, CRIMPER	2
1	1	-	C	4-456406-7	CRIMPER, WIRE	1

LOC	LEADMAKER	AMP-O-LECTRIC
A		
DIST	T TERMINATING UNIT	K TERMINATING UNIT
66		

DIMENSIONS IN INCHES. DO NOT SCALE PRINT. TOLERANCES UNLESS OTHERWISE SPECIFIED.

DR 5/12/93 APP 5/14/93
M. O'BRINE B. WOLFE
CHK 5/13/93 REL 5/20/93
C. ERISMANN M. ENTERLINE

AMP Incorporated Harrisburg, PA 17105-3608

NAME: END FEED HDM APPLICATOR MACHINE REF: MINI APPL

SCALE: - DWG NO: 680009 SHEET 1 OF 1 REV A