

# Board Level Heat Sinks

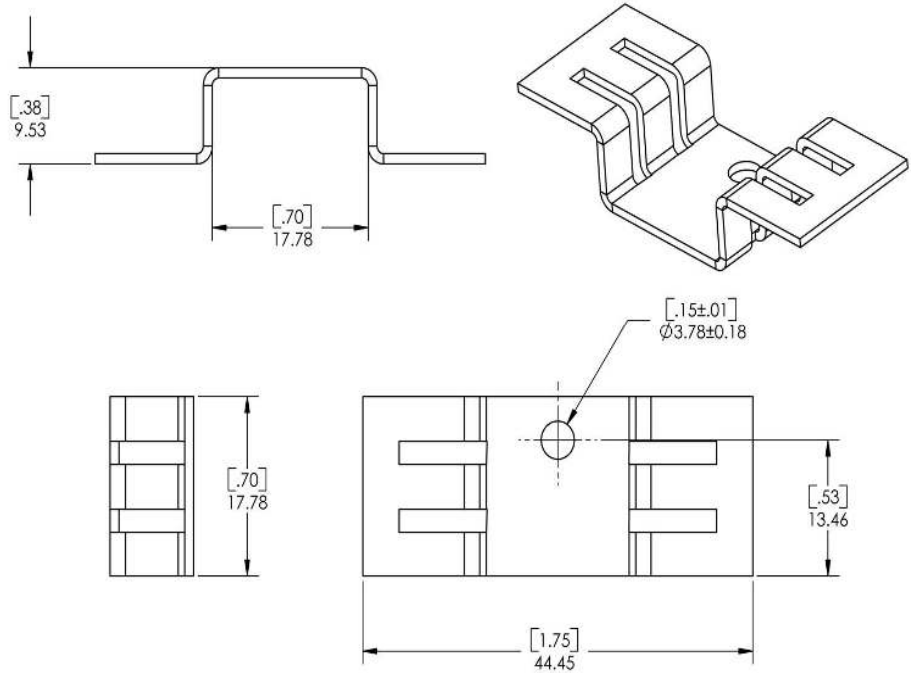

ThermaFlo

**P/N: 822802B00000**

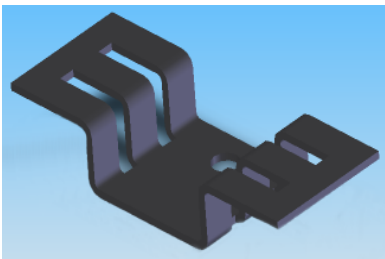

**TO-220**

## PRODUCT SPECIFICATIONS

- Devices: TO-220
- Size: 17.8 x 44.5 x 9.5 mm
- Material: Aluminum, 1.0 mm Thick
- Weight: 2.5 grams
- Type: Stamped
- PCB Mounting: Device Leads
- Finish: Black Anodized
- Package: Bulk
- Accessories: Hardware & Thermal Interface Material

## FEATURES & BENEFITS

- Hole for Device Attachment
- RoHS Compliant



## CUSTOMIZED HEATSINKS

- Specialized Plating
- Specialized Body Configurations
- Contact Applications Engineering

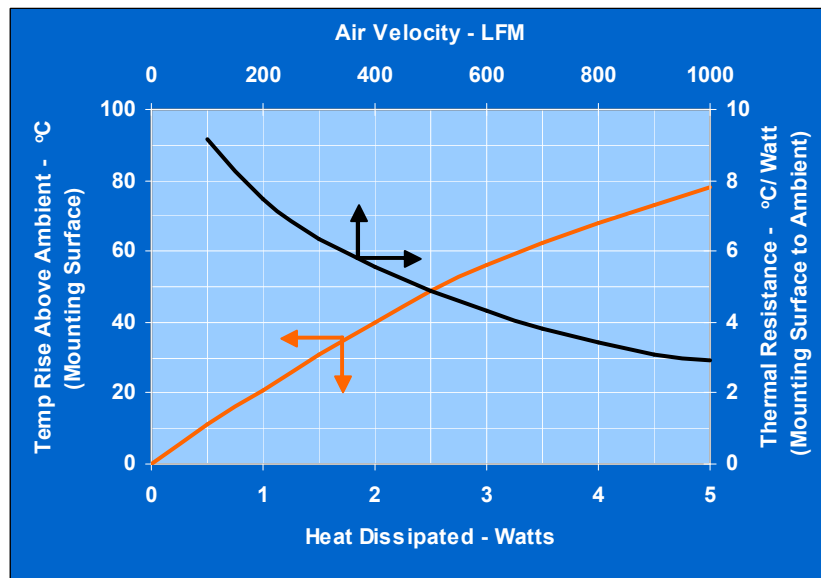

**COMAIR ROTRON, INC**  
 8929 Terman Court, San Diego, CA 92121  
 Ph (858) 348-6200 Fax (858) 566-4577  
 E-mail: sales@comairrotron.com,  
 Web: www.comairrotron.com