

SYMBOL		REVISIONS		
SYM	ZONE	ECN, ERN NO.	DATE	APPRD.
A		REVISED PROPOSAL DRAWING	Sep 29,09	L.CHAN
B		REVISED PROPOSAL DRAWING	Oct 14 ,09	L.CHAN
C		REVISED PROPOSAL DRAWING	Dec 3 ,09	L.CHAN
D		REVISED PROPOSAL DRAWING	JUL 26,11	L.CHAN

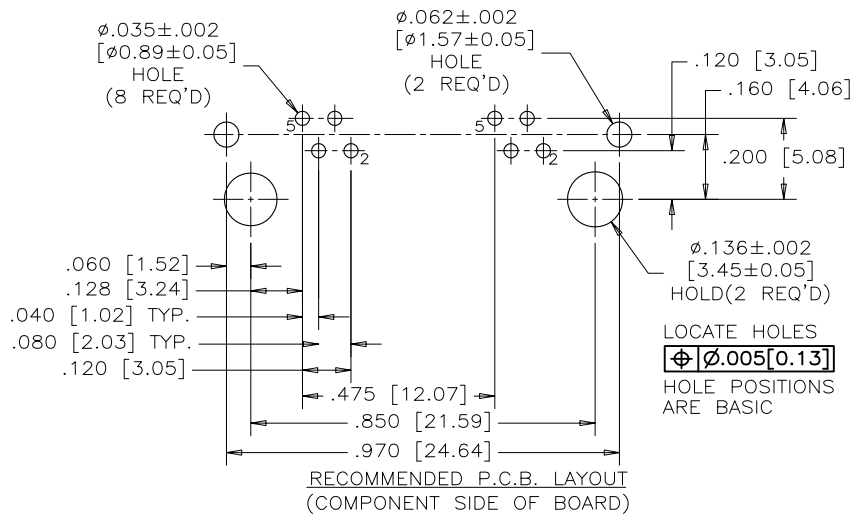

LOCATE HOLES
 $\text{H}\text{O}\text{L}\text{E}\ \text{P}\text{O}\text{S}\text{I}\text{T}\text{I}\text{O}\text{N}\text{S}\ \text{A}\text{R}\text{E}\ \text{B}\text{A}\text{S}\text{I}\text{C}$
 $\text{H}\text{O}\text{L}\text{E}\ \text{D}\text{I}\text{A}\text{M}\text{E}\text{T}\text{E}\ \text{I}\text{S}\ \text{B}\text{A}\text{S}\text{I}\text{C}$

RECOMMENDED P.C.B. LAYOUT
 (COMPONENT SIDE OF BOARD)

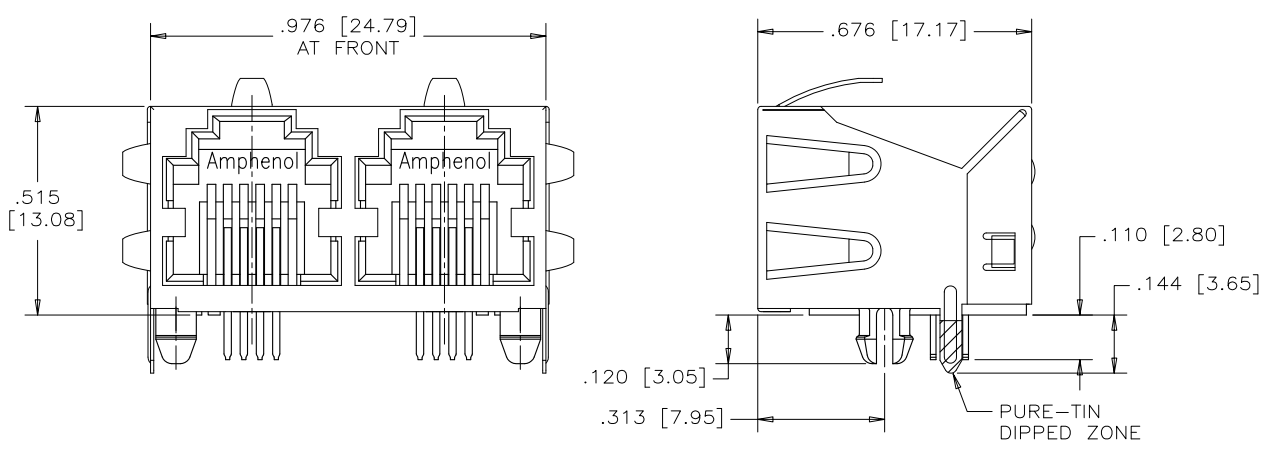
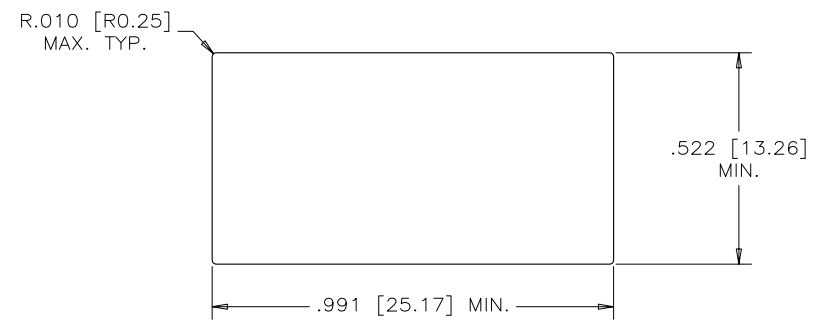

RECOMMENDED PANEL CUTOUT

MATERIALS:

- PLASTIC HOUSING: HIGH TEMPERATURE RESISTANT NYLON
 UL FLAMMABILITY RATING 94V-0.
 COLOR: BLACK
- CONTACTS: PHOSPHOR BRONZE
- CONTACT PLATING: 50 u" [1.27 MICRONS] MINIMUM GOLD
 ON MATING SURFACES
 50 u" [1.27 MICRONS] MINIMUM NICKEL
 UNDERPLATE
 100 u" [2.54 MICRONS] MATTE TIN
 ON CONTACT TAILS.
- SHIELD: COPPER ALLOY; NICKEL PLATED WITH PURE-TIN
 DIPPED PCB TAILS.

ELECTRICAL

- VOLTAGE RATING: 125 VAC RMS MAX.
- CURRENT RATING: 1.5 AMPS MAX.
- CONTACT RESISTANCE: 30 MILLIOHMS MAX.
- INSULATION RESISTANCE: 500 MEGAOHMS MIN.
- DWV: 1000VAC RMS BETWEEN ADJACENT CONTACTS, 60HZ, 1 MIN.
 1500VAC RMS BETWEEN CONTACTS & SHIELD, 60HZ, 1 MIN.

MECHANICAL

- MATING DURABILITY: 500 CYCLES MIN.
- PCB THICKNESS: .062"
- PCB RETENTION PRE-SOLDER: 1.0 LB MIN.
- PCB RETENTION POST-SOLDER: 10.0 LB MIN.

ENVIRONMENTAL

OPERATION: -40°C TO +85°C

REGULATORY

- UL AND CSA COMPLIANT.
- MEETS FCC PART 68 REQUIREMENTS

PART NUMBER: RJE01-642-02

DRAWN	Huilan Wang	DATE	Sep 29/09
DESIGNED	MT Chen	DATE	Sep 29/09
CHECKED	L.Chan	DATE	Sep 29/09
I. E. APPRD.			
Q. A. APPRD.			
DWG. APPRD.			
ENG. REL. NO.		DWG	DRAWING NO.
REF.	EAR #13597	C	P-RJE01-642-02
DIMENSIONS ARE IN	CODE ID. NO.	SCALE	4/1
INCHES [mm]	03554	WT.	-----

Amphenol Canada Corp.	
TITLE	HIGH SPEED MODULAR JACK, 2 PORT, 6 POSITION, 4 CONTACTS, SHIELDED WITH TOP & SIDE GROUND TABS RoHS COMPLIANT
REV.	D
SHEET	1 OF 1

THIS DOCUMENT CONTAINS PROPRIETARY INFORMATION AND SUCH INFORMATION
 MAY NOT BE DISCLOSED TO OTHERS FOR ANY PURPOSE OR USED FOR MANUFACTURING
 PURPOSES WITHOUT WRITTEN PERMISSION FROM AMPHENOL CANADA CORP.