

THIS DRAWING IS UNPUBLISHED. RELEASED FOR PUBLICATION  
 © COPYRIGHT BY TYCO ELECTRONICS CORPORATION. ALL INTERNATIONAL RIGHTS RESERVED.

LOC		DIST		REVISIONS			
P	LTR	DESCRIPTION	DATE	DWN	APVD		
GP	00	L	REVISED PER ECO-09-001588	25JUN2009	CJV	CWR	

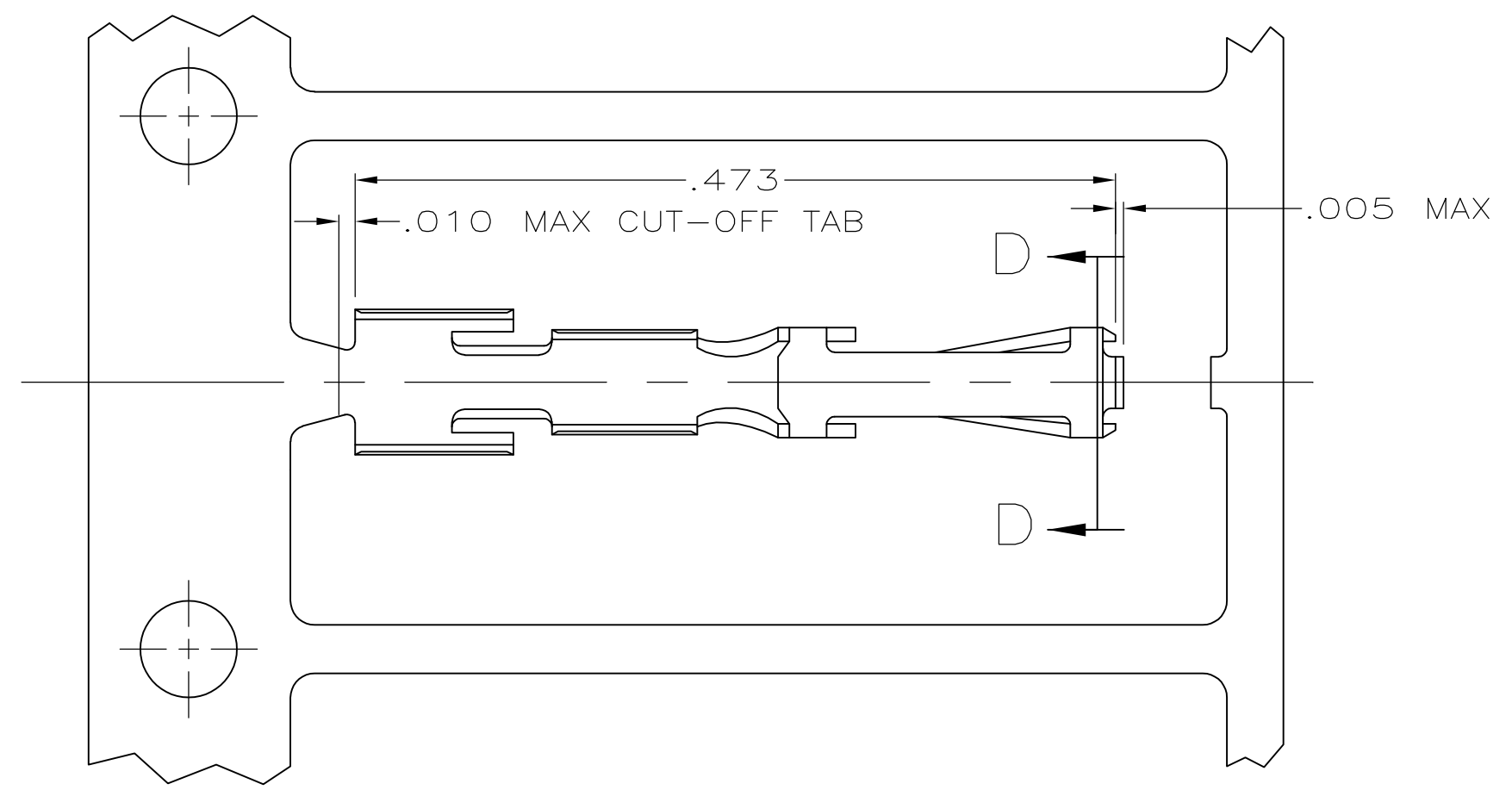

- 1 FOR MINI APPLICATOR
- 2 FINISH: GOLD FLASH ALL OVER .000015 THK GOLD ON LOCALIZED CONTACT PLATING AREA OVER .000050 MIN THK NICKEL ON ENTIRE CONTACT,  
 -OR-  
 .000050 MIN THK NICKEL UNDERPLATE ON ENTIRE CONTACT, GOLD FLASH OVER PALLADIUM-NICKEL, .000015 MIN TOTAL THK ON LOCALIZED CONTACT PLATING AREA AND GOLD FLASH OVER REMAINDER OF CONTACT.
- 3. FOR 22-24 AWG WIRE WITH AN INS. RANGE OF .040-.056 DIA.

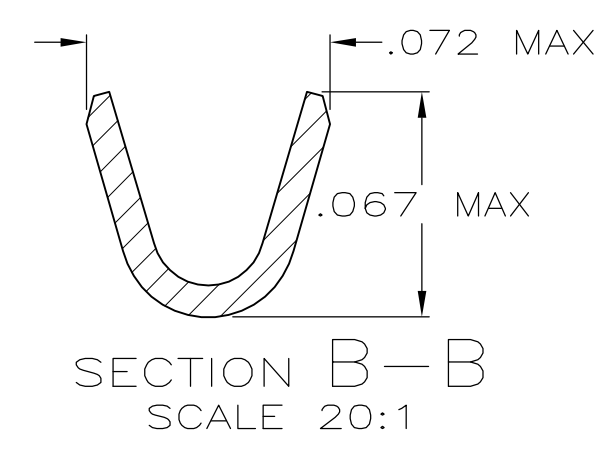
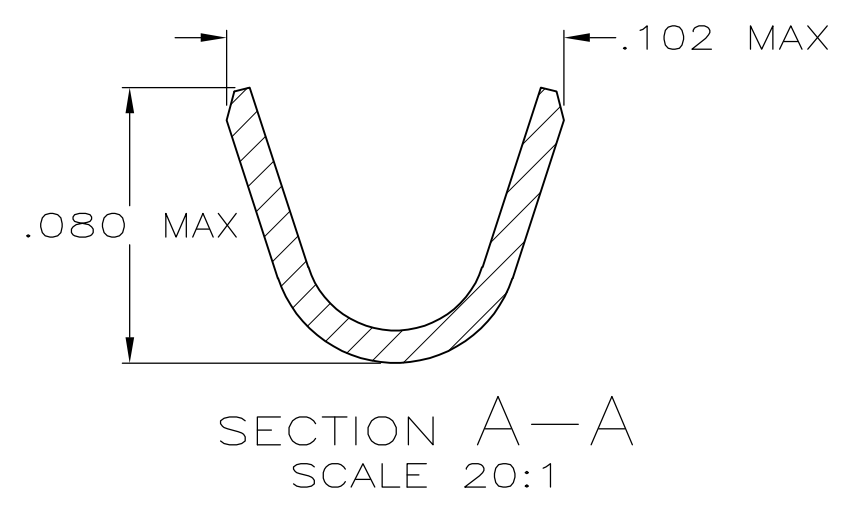
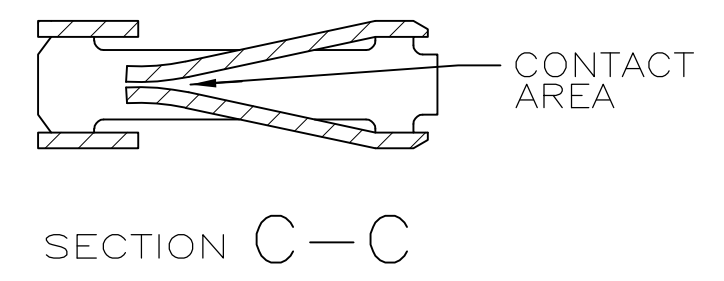
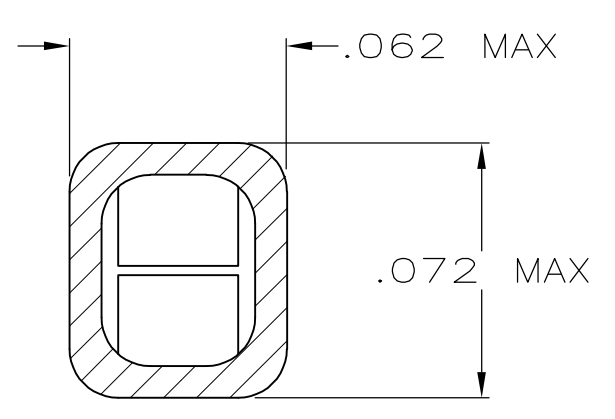
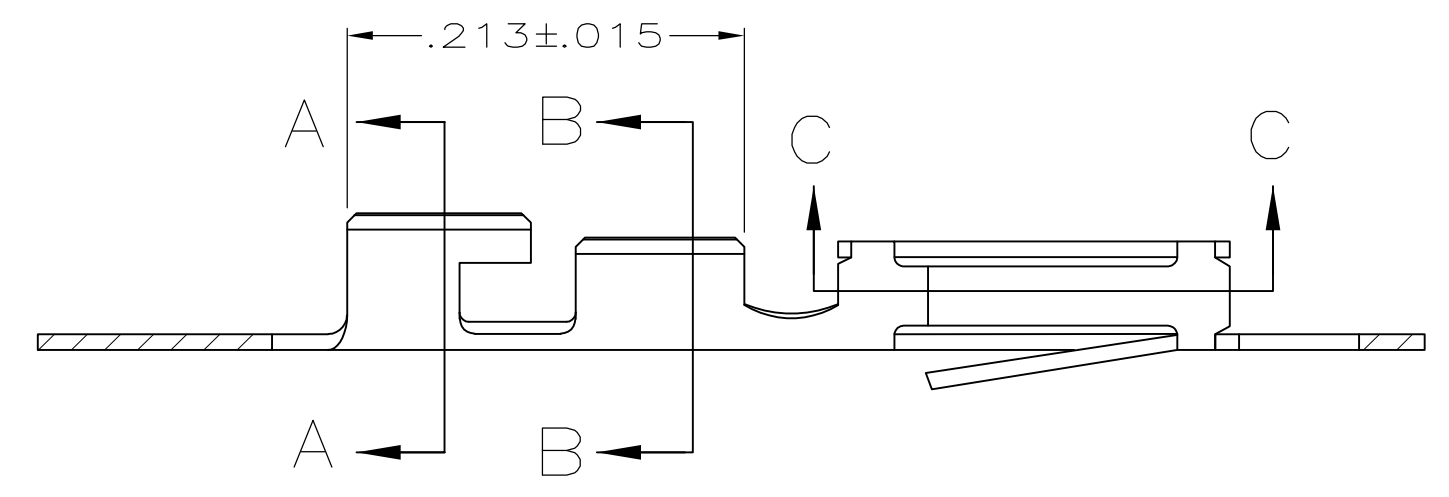

1	2	86657-2	86655-2
REMARKS	FINISH	LOOSE PIECE PART NO.	PART NO.

THIS DRAWING IS A CONTROLLED DOCUMENT.		DWN B. MOYER 6-8-89	Tyco Electronics Corporation Harrisburg, PA 17105-3608	
DIMENSIONS: INCHES		CHK D.L. ROCKER 6-8-89	NAME C.D. MILLER 6-14-89	
TOLERANCES UNLESS OTHERWISE SPECIFIED:		PRODUCT SPEC 108-9024	CONTACT, RCPT., ROUND WIRE, .100 CENTERLINE, FFC	
0 PLC ± - 1 PLC ± - 2 PLC ± - 3 PLC ± .005 4 PLC ± - ANGLES ± -		APPLICATION SPEC 114-16003	SIZE A2	RESTRICTED TO -
MATERIAL PHOS. BRONZE	FINISH SEE TABLE	WEIGHT -	CAGE CODE 00779	DRAWING NO C=86655
CUSTOMER DRAWING			SCALE 10:1	SHEET 1 of 1