



# American Opto Plus LED Corp.

## L152L-QOC-TR

3.2 x 1.6 x 1.1 mm Orange SMD LED

### PACKAGE DIMENSION

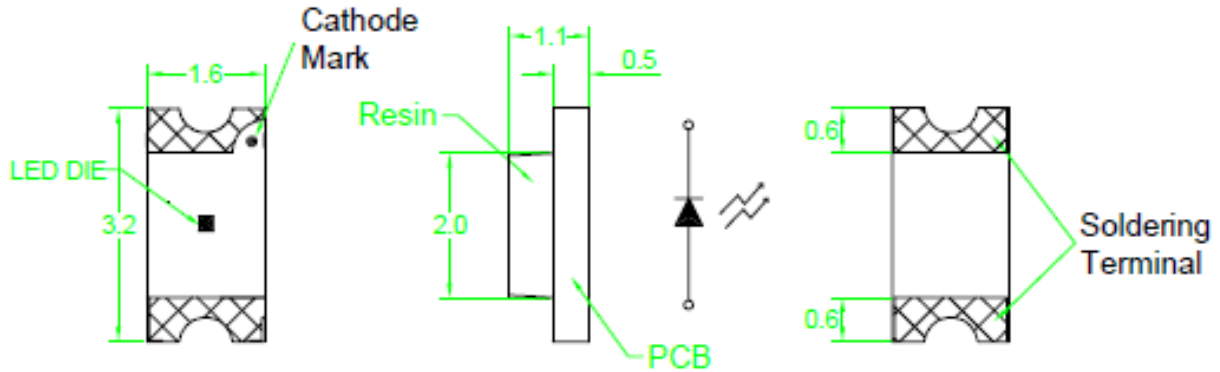

### NOTES:

1. All dimension are in millimeter tolerance is  $\pm 0.1$ mm unless otherwise noted.
2. Specifications are subject to change without notice.

### Recommended Solder Pad

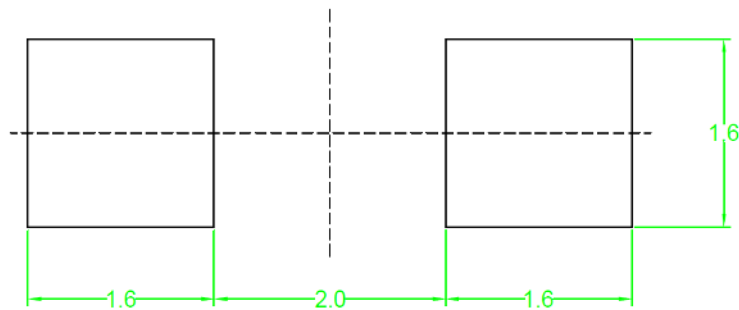

Note : The tolerances unless mentioned is  $\pm 0.1$ mm, Angle  $\pm 0.5$ . Unit=mm.

| Chip Material | Chip Emitted | Lens Color  | Viewing Angle |
|---------------|--------------|-------------|---------------|
| AlGaInP       | Orange       | Water Clear | 140           |



# American Opto Plus LED Corp.

## L152L-QOC-TR

3.2 x 1.6 x 1.1 mm Orange SMD LED

### ABSOLUTE MAXIMUM RATINGS

(Ta=25°C)

| Parameter                                 | Symbol           | Value                   | Unit |
|---|------------------|-------------------------|------|
| Forward current                           | I <sub>f</sub>   | 30                      | mA   |
| Reverse current @ 5V                      | I <sub>r</sub>   | 10                      | μA   |
| Power dissipation                         | P <sub>d</sub>   | 78                      | mW   |
| Operating temperature range               | T <sub>opr</sub> | -40~+85                 | °C   |
| Storage temperature range                 | T <sub>stg</sub> | -40~+90                 | °C   |
| Peak pulsing current (1/10 duty f= 10KHz) | I <sub>fp</sub>  | 60                      | mA   |
| Electrostatic Discharge                   | ESD              | 2000                    | V    |
| Soldering Temperature                     | T <sub>SOL</sub> | Max 260°C for 5 sec Max |      |

### TYPICAL & OPTICAL-ELECTRICAL CHARACTERISTICS (Ta=25°C)

| Parameter                           | Symbol            | Test Condition        | Value |     |     | Unit |
|-------------------------------------|-------------------|-----------------------|-------|-----|-----|------|
|                                     |                   |                       | Min   | Typ | Max |      |
| Wavelength at peak emission         | λ <sub>peak</sub> | I <sub>F</sub> = 20mA | -     | 610 | -   | nm   |
| Spectral half bandwidth             | Δλ                | I <sub>F</sub> = 20mA | -     | 17  | -   | nm   |
| Dominant wavelength                 | λ <sub>D</sub>    | I <sub>F</sub> = 20mA | -     | 605 | -   | nm   |
| Forward Voltage                     | V <sub>f</sub>    | I <sub>F</sub> = 20mA | 1.7   | -   | 2.6 | V    |
| Luminous intensity                  | I <sub>v</sub>    | I <sub>F</sub> = 20mA | 32    | 125 | -   | mcd  |
| Viewing angle at 50% I <sub>v</sub> | 2θ ½              | I <sub>F</sub> = 20mA | -     | 140 | -   | Deg  |

Note : 1.The forward voltage data did not including ±0.1V testing tolerance.  
 2. The luminous intensity data did not including ±15% testing tolerance.



# American Opto Plus LED Corp.

## L152L-QOC-TR

3.2 x 1.6 x 1.1 mm Orange SMD LED

### OPTICAL CHARACTERISTIC CURVES

Fig.1 Forward current vs. Forward Voltage

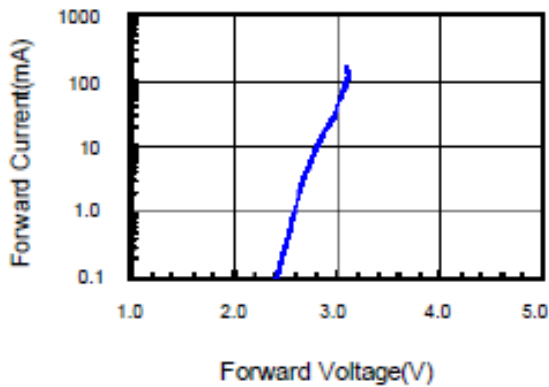

Fig.2 Relative Intensity vs. Forward Current

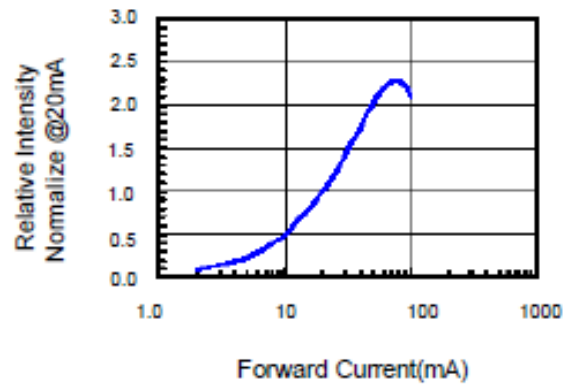

Fig.3 Forward Voltage vs. Temperature

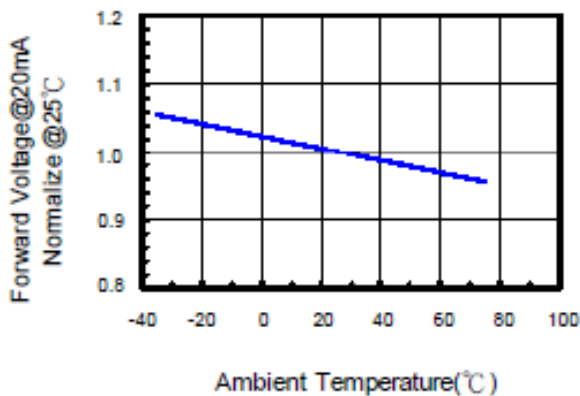

Fig.4 Relative Intensity vs. Temperature

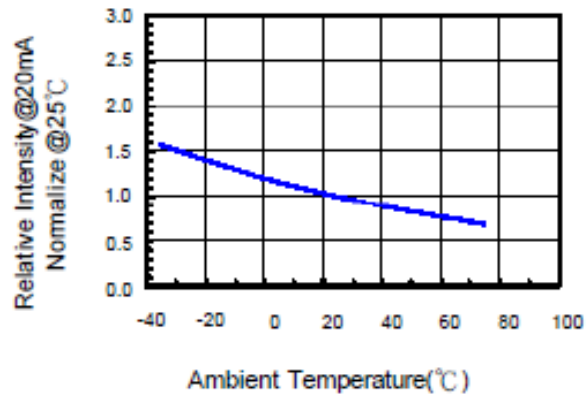

Fig.5 Relative Intensity vs. Wavelength

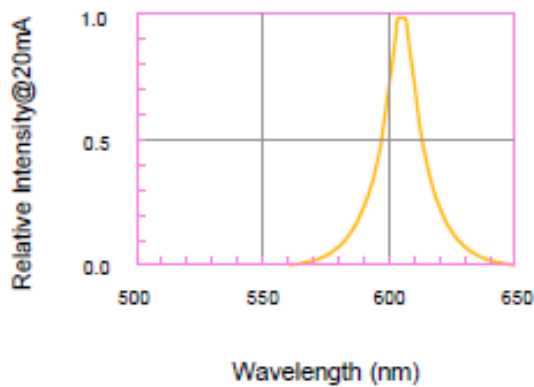
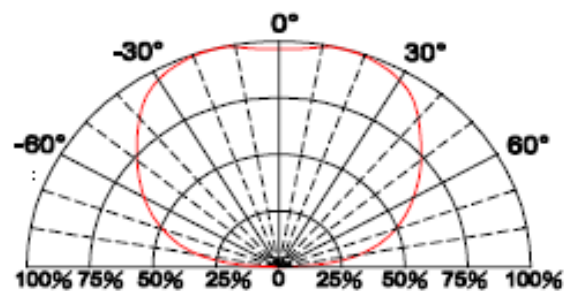

Fig.6 Directive Radiation





# American Opto Plus LED Corp.

## L152L-QOC-TR

3.2 x 1.6 x 1.1 mm Orange SMD LED

### Dimensions of Tape (Unit: mm)

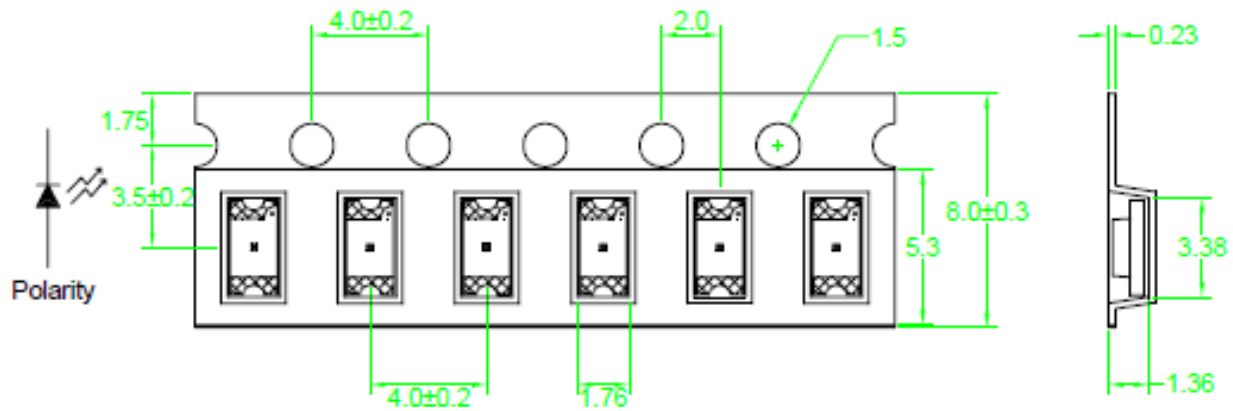

Note : The tolerances unless mentioned is  $\pm 0.1$ mm, Angle  $\pm 0.5$ . Unit=mm.

### PACKAGING SPECIFICATION

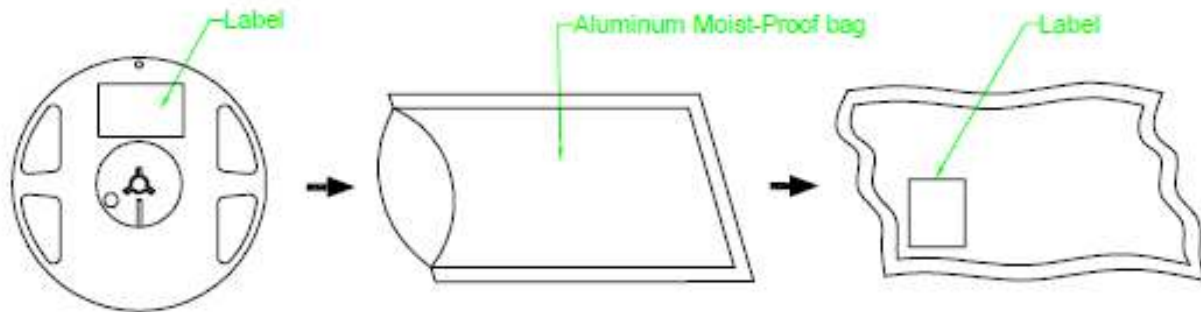



**American Opto Plus LED Corp.**

**L152L-QOC-TR**

**3.2 x 1.6 x 1.1 mm Orange SMD LED**

## REEL DIMENSIONS

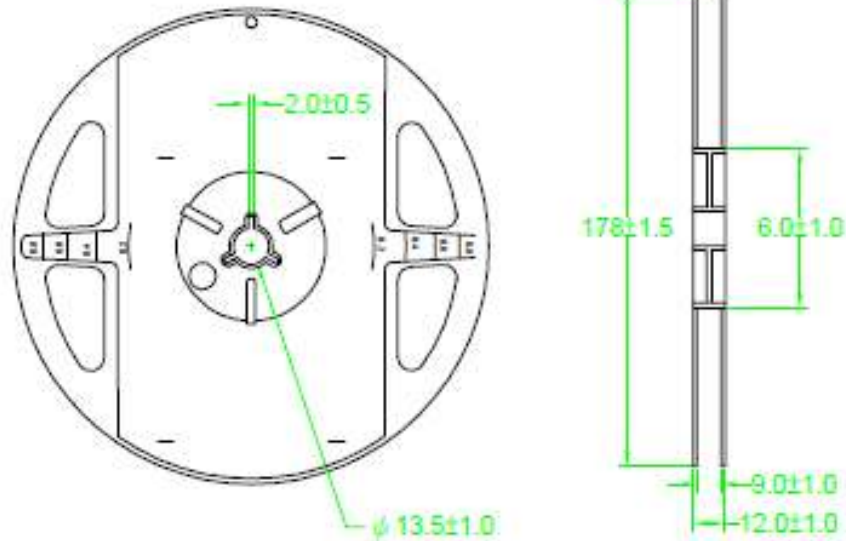

### Notes:

1. Empty component pockets are sealed with top cover tape;
2. The maximum number of missing lamps is two;
3. The cathode is oriented towards the tape sprocket hole.
4. 3,000pcs/Reel



# American Opto Plus LED Corp.

## L152L-QOC-TR

3.2 x 1.6 x 1.1 mm Orange SMD LED

### Recommended Soldering Conditions

#### 1. Hand Solder

Basic spec is  $\leq 280^{\circ}\text{C}$  3 sec one time only.

#### 2. Wave Solder

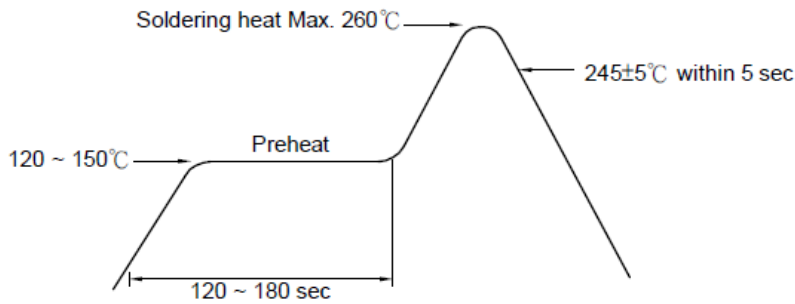

#### 3-1. LEAD Reflow Solder

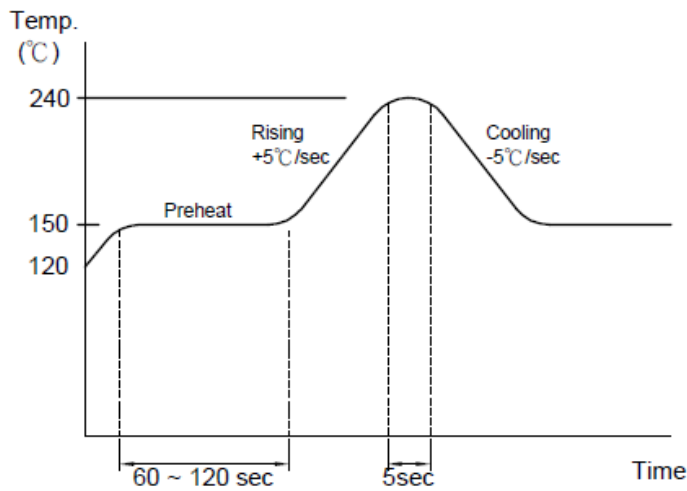

#### 3-2 PB-Free Reflow Solder

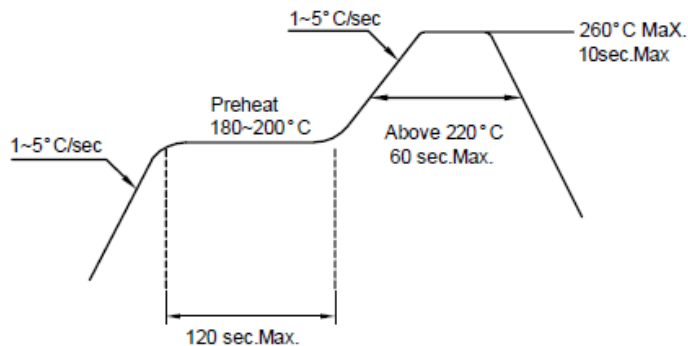

Reflow Soldering should not be done more than two times.



# American Opto Plus LED Corp.

## L152L-QOC-TR

3.2 x 1.6 x 1.1 mm Orange SMD LED

### Precautions For Use:

#### Storage time:

1. The operation of Temperatures and RH are :  $5^{\circ}\text{C} \sim 35^{\circ}\text{C}$ , RH60%.
2. Once the package is opened, the products should be used within a week. Otherwise, they should be kept in a damp proof box with desiccating agent. Considering the tape life, we suggest our customers to use our products within a year (from production date).
3. If opened more than one week in an atmosphere  $5^{\circ}\text{C} \sim 35^{\circ}\text{C}$ , RH60%, they should be treated at  $60^{\circ}\text{C} \pm 5^{\circ}\text{C}$  for 15hrs.

### Drive Method:

LED is a current operated device, and therefore, requires some kind of current limiting incorporated into the driver circuit. This current limiting typically takes the form of a current limiting resistor placed in series with the LED.

Consider worst case voltage variations that could occur across the current limiting resistor. The forward current should not be allowed to change by more than 40 % of its desired value.

Circuit model A



Circuit model B

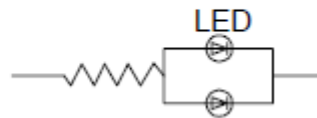

(A) Recommended circuit.

(B) The difference of brightness between LED could be found due to the VF-IF characteristics of LED.

### ESD(Electrostatic Discharge):

Static Electricity or power surge will damage the LED. Use of a conductive wrist band or anti-electrostatic glove is recommended when handling these LED. All devices, equipment and machinery must be properly grounded.



# American Opto Plus LED Corp.

## L152L-QOC-TR

3.2 x 1.6 x 1.1 mm Orange SMD LED

### RELIABILITY TEST

| Classification     | Test Item                                   | Test Condition   | Reference Standard  |
|--------------------|---|--|---|
| Endurance Test     | Operating Life Test                         | 1. Ta=Under Room Temperature As Per Data Sheet Maximum Rating.<br>2. If=20mA<br>3. t=1000 hrs (-24hrs, +72hrs) | MIL-STD-750D: 1026<br>MIL-STD-883D: 1005<br>JIS C 7021: B-1   |
|                    | High Temperature Storage Test               | 1. Ta=105°C±5°C<br>2. t=1000 hrs (-24hrs, +72hrs)  | MIL-STD-883D:1008<br>JIS C 7021: B-10   |
|                    | Low Temperature Storage Test                | 1. Ta=-40°C±5°C<br>2. t=1000 hrs (-24hrs, +72hrs)  | JIS C 7021: B-12  |
|                    | High Temperature High Humidity Storage Test | 1. Ta=65°C±5°C<br>2. RH=90%~95%<br>3. t=1000hrs±2hrs   | MIL-STD-202F:103B<br>JIS C 7021: B-11   |
| Environmental Test | Thermal Shock Test                          | 1. Ta=105°C±5°C & -40°C±5°C<br>(10min) (10min)<br>2. total 10 cycles   | MIL-STD-202F: 107D<br>MIL-STD-750D: 1051<br>MIL-STD-883D: 1011  |
|                    | Solderability Test                          | 1. T.Sol=235°C±5°C<br>2. Immersion time 2±0.5sec<br>3. Coverage ≥95% of the dipped surface                     | MIL-STD-202F: 208D<br>MIL-STD-750D: 2026<br>MIL-STD-883D: 2003<br>IEC 68 Part 2-20<br>JIS C 7021: A-2 |
|                    | Temperature Cycling                         | 1. 105°C ~ 25°C ~ -55°C ~ 25°C<br>30mins 5mins 30mins 5mins<br>2. 10 Cycles                                    | MIL-STD-202F: 107D<br>MIL-STD-750D: 1051<br>MIL-STD-883D: 1010<br>JIS C 7021: A-4                     |
|                    | IR Reflow                                   | 1. T=260°C Max. 10sec.Max.<br>2. 6 Min   | MIL-STD-750D:2031.2<br>J-STD-020  |