

PART NAME

NEMA 4X PLASTIC BOX w/EXTERNAL MTG. BRKT.

PART No.

PN-1322-MB PN-1322-CMB PN-1322-DGMB

REVISION DATE

3-13-17

## MATERIAL &amp; FINISH:

(-MB SUFFIX PART NO.) POLYCARBONATE UL94-HB, UV STABILIZED, SERVICE TEMPERATURE RANGE: -40°C TO +120°C, LIGHT GRAY BODY & COVER.  
 (-CMB SUFFIX PART NO.) SAME AS -MB EXCEPT CLEAR COVER.  
 (-DGMB SUFFIX PART NO.) ABS UL94-HB, SERVICE TEMPERATURE RANGE: -40°C TO +80°C, DARK GRAY BODY & COVER.

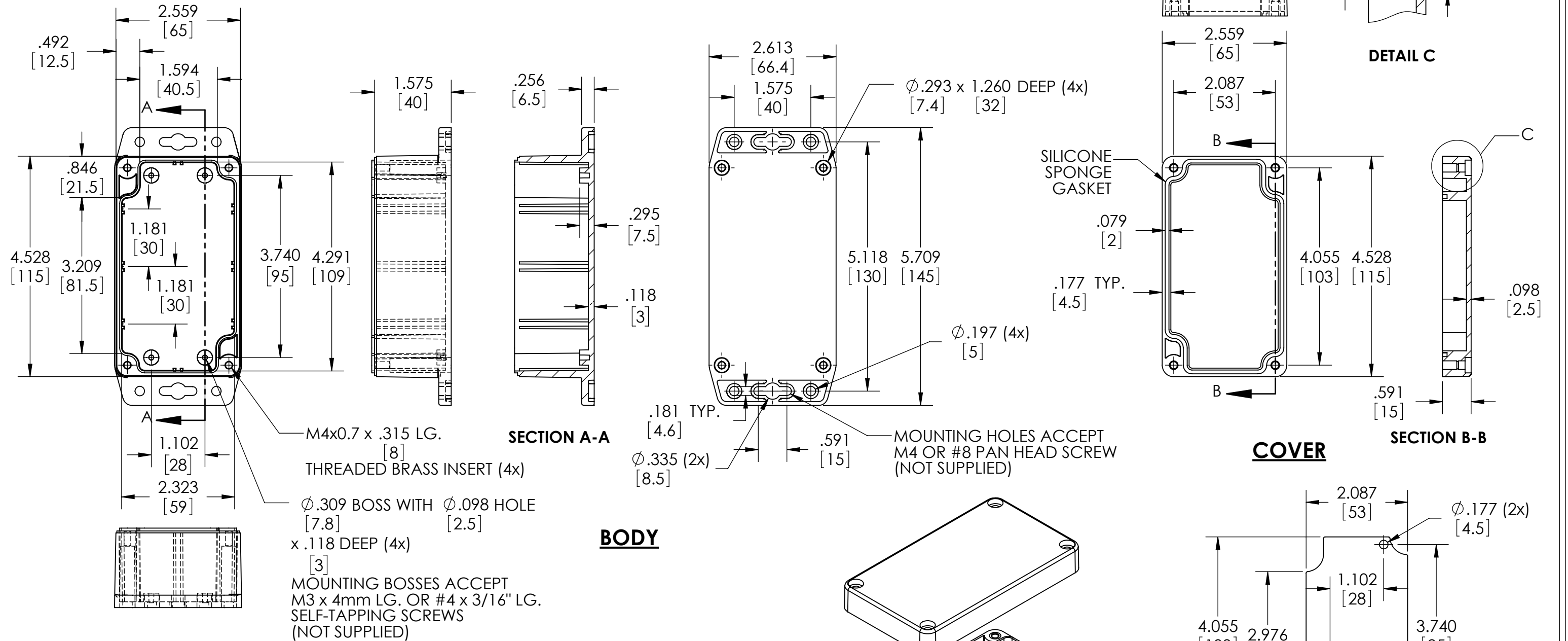

## NOTES:

- FOUR (4) M4x0.7 x 20mm (.787") LG. STAINLESS STEEL SCREWS SUPPLIED FOR ASSEMBLY OF COVER TO BODY.
- BOXES DESIGNED TO MEET FOLLOWING STANDARDS:  
NEMA 1, 2, 4, 4X, 12, 13 AND IEC529-IP65 REQUIREMENTS.
- ALL HOLE DIAMETERS HAVE  $\pm .005$  [.12] TOLERANCE.  
ALL OTHER DIMENSIONS HAVE  $\pm .015$  [.38] TOLERANCE.
- ALL OUTSIDE DRAFT ANGLE:  $1^\circ$   
ALL INSIDE DRAFT ANGLE:  $1/2^\circ$