

LOC		DIST		REVISIONS			
P	LTR	DESCRIPTION	DATE	DN	APVD		
AA	REV PER ECO	15-016064	11-9-15	CT	CD		

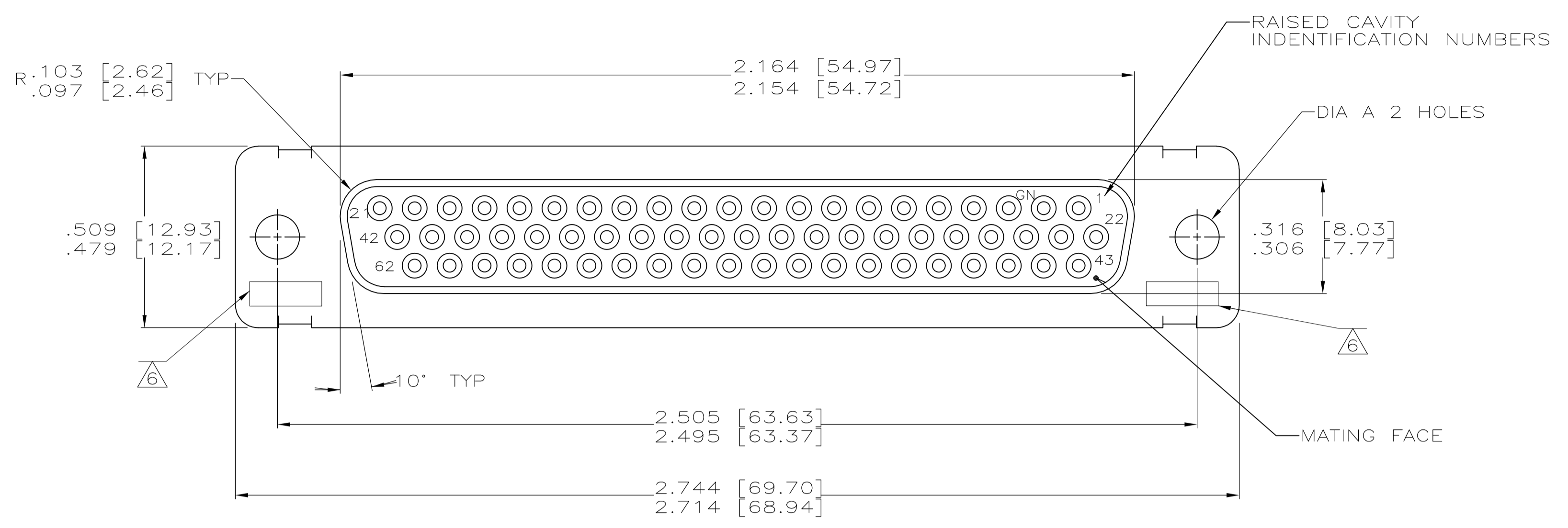

1. THIS RECEPTACLE WILL MATE WITH ANY PLUG CONNECTOR WITH SAME INSERT ARRANGEMENT AS DEFINED BY MS18276-2.
2. MAXIMUM WIRE INSULATION USED WITH THIS RCPT. IS .054 DIA.
3. Be-Cu RETENTION CLIPS ARE INCLUDED IN INSERTS.
4. INSPECTION REQUIREMENTS PER R4383.
5. CONNECTOR SUPPLIED WITH 69 CONTACTS, AMP PART NUMBER 206071-1. INSPECTION REQUIREMENTS PER R4383 WITHOUT TESTS FOR HIGH ALTITUDE DIELECTRIC WITHSTANDING VOLTAGE AS CALLED FOR IN TABLE II SCREENING AND TESTING.
6. UL/CSA DESIGNATION STAMPED IN THIS AREA, OPTIONAL
7. SPECIAL TESTING PER GE DOCUMENT 20025720. CONNECTOR SUPPLIED WITH 72 CONTACTS, AMP P/N 206071-1.
8. RESTRICTED TO CAE ELECTRONICS ONLY.
9. THESE CONNECTORS ARE QUALIFIED TO GODDARD SPACE FLIGHT CENTER SPECIFICATION S-311-P-4.

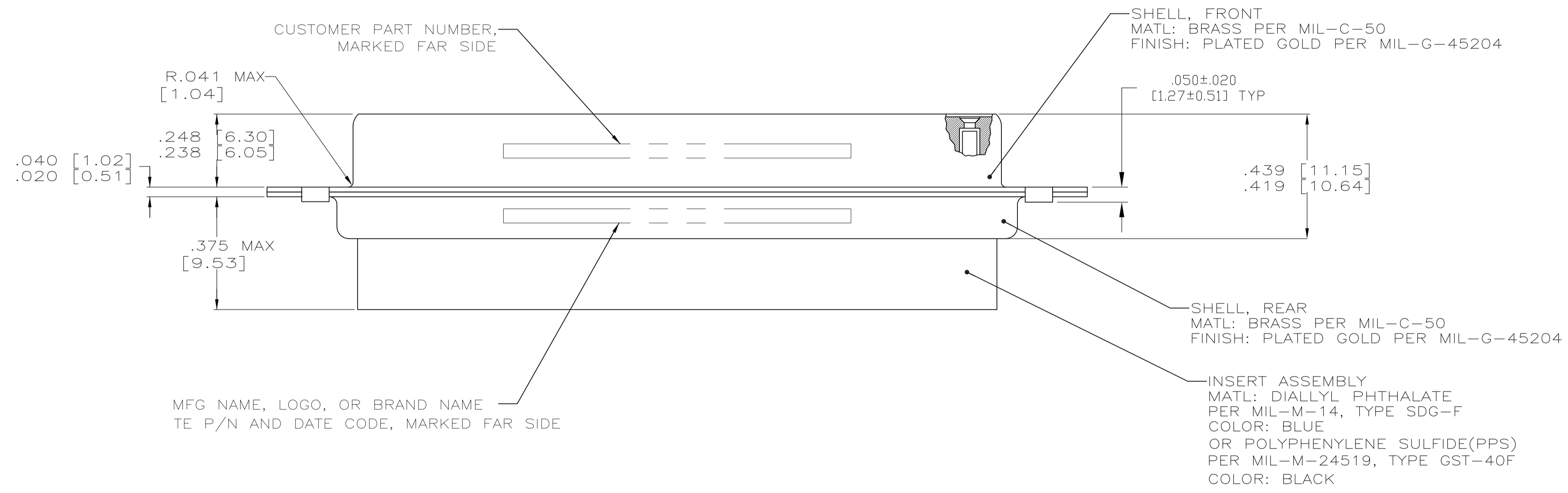

AMP P/N 206071-1
 GSFC P/N G-08-S1
 (SUPPLIED WITH 206064-6 AND 206064-8 ONLY)

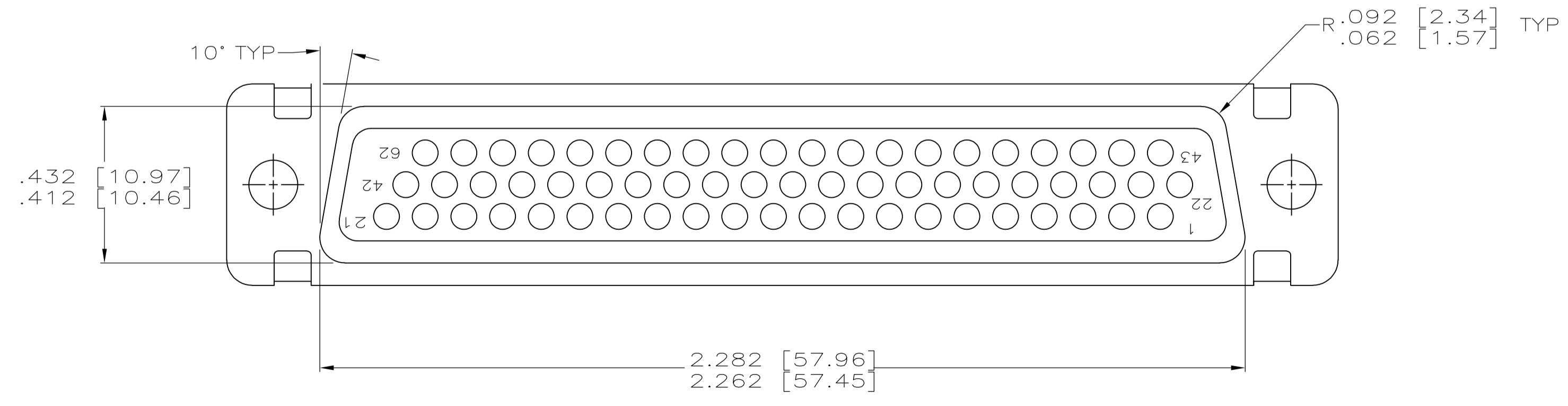

SUPERSEDED BY 1996014-4

REMARKS	DIA A	QTY	PART NO	TE P/N ON CONNECTOR	PART NUMBER
---	.120	8333648P1	1-206503-2	1-206503-2	
---	.120	570566-4	1-206503-1	1-206503-1	
8 9	.120	311P407-4S-B-12	206503-4	206503-9	
7	.120	20025720P1062S	206503-8	206503-8	
---	.154	SC81D139-044	206503-7	206503-7	
5	.120	R4383P62S	206503-6	206503-6	
4	.120	R4383P62S-2	206503-5	206503-5	
3	.120	311P407-4S-B-12	206503-4	206503-4	
---	.154	N/A	206503-3	206503-3	
---	.120	R9259P62S	206503-2	206503-2	
2	.154	311P407-4S-B-15	206503-1	206503-1	

THIS DRAWING IS A CONTROLLED DOCUMENT.

DIMENSIONS: INCHES	TOLERANCES UNLESS OTHERWISE SPECIFIED:	0 PLC ± .005	1 PLC ± .005	2 PLC ± .005	3 PLC ± .005	4 PLC ± .005	ANGLES ± .1°
MATERIAL SEE CALLOUTS	FINISH SEE CALLOUTS	WEIGHT	SIZE A1	CAGE CODE 00779	DRAWING NO. 206503	RESTRICTED TO	

CUSTOMER DRAWING SCALE 4:1 SHEET 1 OF 1 REV AA

STE TE Connectivity
 AMPLIMITE RCPT ASSY, NON-MAGNETIC, SHELL SIZE 4,62 POSITION