

**THE MOFIT • SPECIFICATION CONTROL DRAWING • MOLDED PARTS**

1. All dimensions are in inches; all angles are in degrees.
2. Dimensions appearing in table below are as follows:  
a - As supplied      b - After unrestricted recovery
3. Weight shown in table of dimensions is based on polyolefin part.

NOTES

ORDERING INFORMATION

Matl No.	Description	Rayclad Matl. Spec.	Specific Grav. Max.
3	Polyolefin	RT 301	1.40
4	Flex Poly	RT 1304	1.40

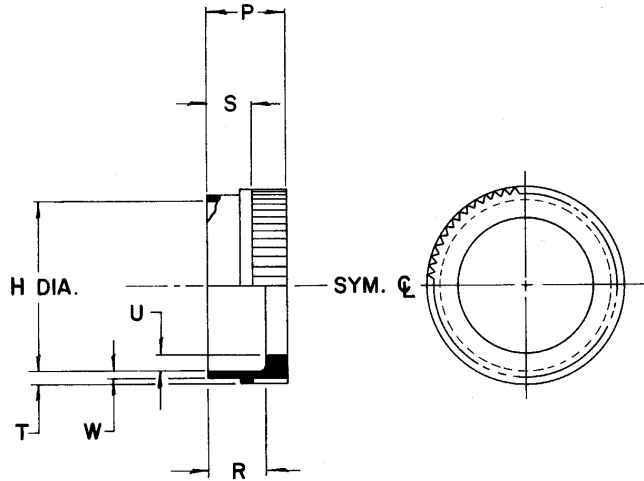

AS SUPPLIED

AFTER UNRESTRICTED RECOVERY

Add material number as suffix to part number;  
Example - Order 201A711-3 when polyolefin is required.

**TABLE OF DIMENSIONS**

PART NO.	H		P		R		S		T		U		W		Weight lbs.	
	Min a	±5% b	a	±10% b	a	±10% b	a	±10% b	a	±20% b	a	Max b	Max a	±20% b	Max	
201A711-	.57	.51	—	.44	—	.32	—	.25	—	.10	—	.06	—	.03		.0024
201A722-	.70	.62	—	.44	—	.32	—	.25	—	.10	—	.06	—	.03		.0028
201A732-	.78	.68	—	.44	—	.32	—	.25	—	.10	—	.06	—	.03		.0032
201A742-	.90	.80	—	.44	—	.32	—	.25	—	.10	—	.06	—	.03		.0037
201A752-	1.17	.94	—	.44	—	.32	—	.25	—	.10	—	.06	—	.03		.0045
201A772-	1.40	1.16	—	.44	—	.32	—	.25	—	.10	—	.06	—	.03		.0054
201A792-	1.62	1.40	—	.44	—	.32	—	.25	—	.10	—	.06	—	.03		.0065

PART NO.	This Part Fits Connector Shell Size						Weight lbs.	Max		
	MIL-C-26482 Type "E"									
	Cannon	Bendix	Burndy	Deutsch	Amphenol*	NAS 1599**				
201A711-	8	8	8	10	—	—				
201A722-	10	10	—	—	—	—				
201A732-	12	12	10	12	10	10				
201A742-	14	14	12	14	12	12				
201A752-	16, 18	16, 18	14, 16	16, 18	14, 16	14, 16				
201A772-	20, 22	20, 22	18, 20	20, 22	18	18, 20				
201A792-	24	24	22, 24	24	22	22, 24				

**Raychem**

If this document is printed it becomes uncontrolled.  
Check for the latest revision.

E.O.	REV	DATE
HOP	A	7/67
VDL	B	9/71
BT	C	9/73

DESCRIPTION  
\*Amphenol series 48 less clamp.  
\*\*1599 with NAS 1665 end bell.  
201A722 added.  
Flex Poly added. T dim. changed.  
T & U dim. changed

DRN	DD
CHK'D	KT
AUTH	RAP
AUTH	HOP

PART DESCRIPTION  
**SLEEVE, CONNECTOR ADAPTER**

PART NO.  
**201A711 thru 792**

REV LTR  
**C**

DATE  
September 15, 1973