

7 6 5 4 3 2 1

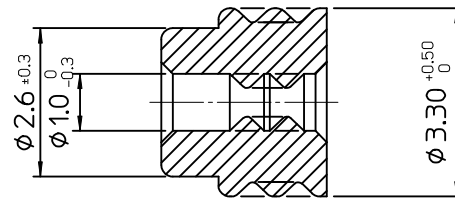

SECTION A-A

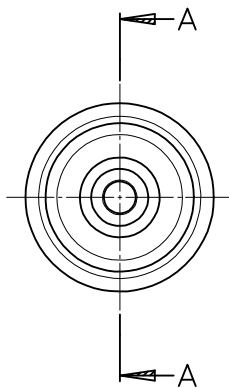
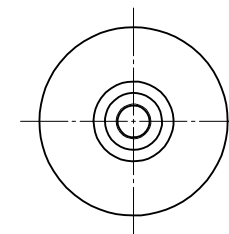

NOTES

1. MATERIAL: SILICONE
2. COLOR:BLACK
3. FLASH:0.2mm MAX.
4. APPLICABLE WIRE:1.1mm
5. APPLICABLE TERMINAL:104493-8041

<TABLE 1>

MATERIAL NO.	ORDER NO.
1044939001	104493-9001

NEW RELEASE EC NO: KTR2013-0014 DRW:HH1M00N 2012/11/21 CHKD: APPR:	DESCRIPTION A	QUALITY SYMBOLS ▽=0 ▽=0	GENERAL TOLERANCES (UNLESS SPECIFIED)			DIMENSION STYLE MM ONLY		SCALE 10:1	DESIGN UNITS METRIC	THIRD ANGLE PROJECTION 		
				mm	INCH	DRAWN BY SMK1M	DATE 2007/05/23	TITLE WIRE SEAL FOR SVM TERMINAL				
			4 PLACES	± ---	± ---	CHECKED BY BCYOON	DATE 2007/05/23					
			3 PLACES	± ---	± ---	APPROVED BY JYCHOI	DATE 2013/02/14	MOLEX INCORPORATED DOCUMENT NO. SD-104493-002 SHEET NO. 1 OF 1				
2 PLACES	± 0.10	± ---	MATERIAL NO. SEE TABLE 1 SIZE A 4									
1 PLACE	± 0.15	± ---	DRAFT WHERE APPLICABLE MUST REMAIN WITHIN DIMENSIONS			THIS DRAWING CONTAINS INFORMATION THAT IS PROPRIETARY TO MOLEX INCORPORATED AND SHOULD NOT BE USED WITHOUT WRITTEN PERMISSION						

6 5 4 3 2 1

E

D

C

B

A

E

D

C

B

A

7 6 5 4 3 2 1

NOTES

- 1.MATERIAL: LUBRICATED SILICONE RUBBER, COLOR;BALCK
- 2.APPLICABLE WIRE SIZE: 0.5~0.85mm²
- 3.APPLICABLE TERMINAL: 35477-9002,35477-9702
- 4.APPLICABLE SOCKET: 68147,49505

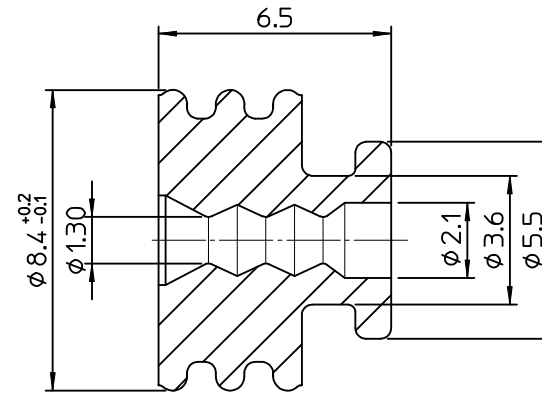
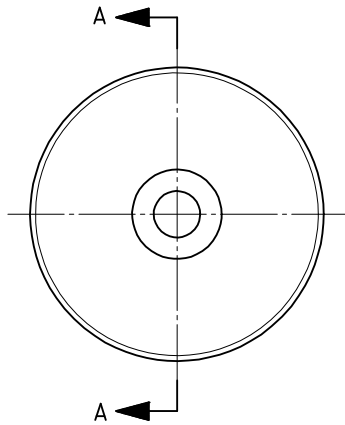

SECTION A-A

<TABLE 1>

MATERIAL NO.	ORDER NO.
495059001	49505-9001

DESIGN UNITS METRIC	THIRD ANGLE PROJECTION
------------------------	---------------------------

NEW RELEASED EC NO: KOR2010-0010 DRW: EOKIM 2009/07/29 CHKD: BCYOON 2009/07/30 APPR: YUNSIKKIM 2009/07/30	DESCRIPTION A	QUALITY SYMBOLS ▽=0 ▽=0	GENERAL TOLERANCES (UNLESS SPECIFIED)		DIMENSION STYLE MM ONLY		SCALE 5:1	TITLE			
				mm	INCH	DRAWN BY SMKIM	DATE 2007/06/04	WIRE SEAL FOR WEDGE TERMINAL			
			4 PLACES	± ---	± ---	CHECKED BY BCYOON	DATE 2007/06/04				
			3 PLACES	± ---	± ---	APPROVED BY EHJUNG	DATE 2007/06/04	MOLEX INCORPORATED			
			2 PLACES	± 0.15	± ---	MATERIAL NO. SEE TABLE1					
1 PLACE	± 0.2	± ---	ANGULAR ± 1 °		THIS DRAWING CONTAINS INFORMATION THAT IS PROPRIETARY TO MOLEX INCORPORATED AND SHOULD NOT BE USED WITHOUT WRITTEN PERMISSION						
DRAFT WHERE APPLICABLE MUST REMAIN WITHIN DIMENSIONS											

WIRE SEAL FOR WEDGE TERMINAL

MOLEX INCORPORATED

THIS DRAWING CONTAINS INFORMATION THAT IS PROPRIETARY TO MOLEX INCORPORATED AND SHOULD NOT BE USED WITHOUT WRITTEN PERMISSION

6 5 4 3 2 1