

ELECTRICAL	MECHANICAL	ENVIRONMENTAL
IMPEDANCE <u>50 Ohm</u> FREQUENCY RANGE <u>DC to 6GHz</u> INSERTION LOSS: <u>MAX. 0.05*SQRT(F) dB</u> VSWR: <u>MAX. 1.15@0-3GHz</u> <u>MAX. 1.25@3-6GHz</u> DIELECTRIC WITHSTAND VOLTAGE: <u>MAX. 2500 V RMS</u> INSULATION RESISTANCE <u>MIN. 5000 Mohms</u> PIM3: <u>MAX. -160dBc @2x20W, 900MHz, 1800MHz,</u> <u>2100MHz tested with cable</u>	MATING CYCLES: <u>MIN. 100 CYCLES</u> RECOMMENDED TORQUE: <u>5Nm</u> CABLE PULLING: <u>500N MIN.</u> CABLE TORSION: <u>5Nm MIN.</u>	TEMPERATURE RANGE: <u>-40°~+85°C</u> SALT SPRAY: <u>96H</u> INTERFACE SEAL: <u>IP68(1m, 24h) MATED</u> CLAMP SEAL: <u>IP67(1m, 0.5h)</u>

P	LTR	DESCRIPTION	DATE	DWN	APVD

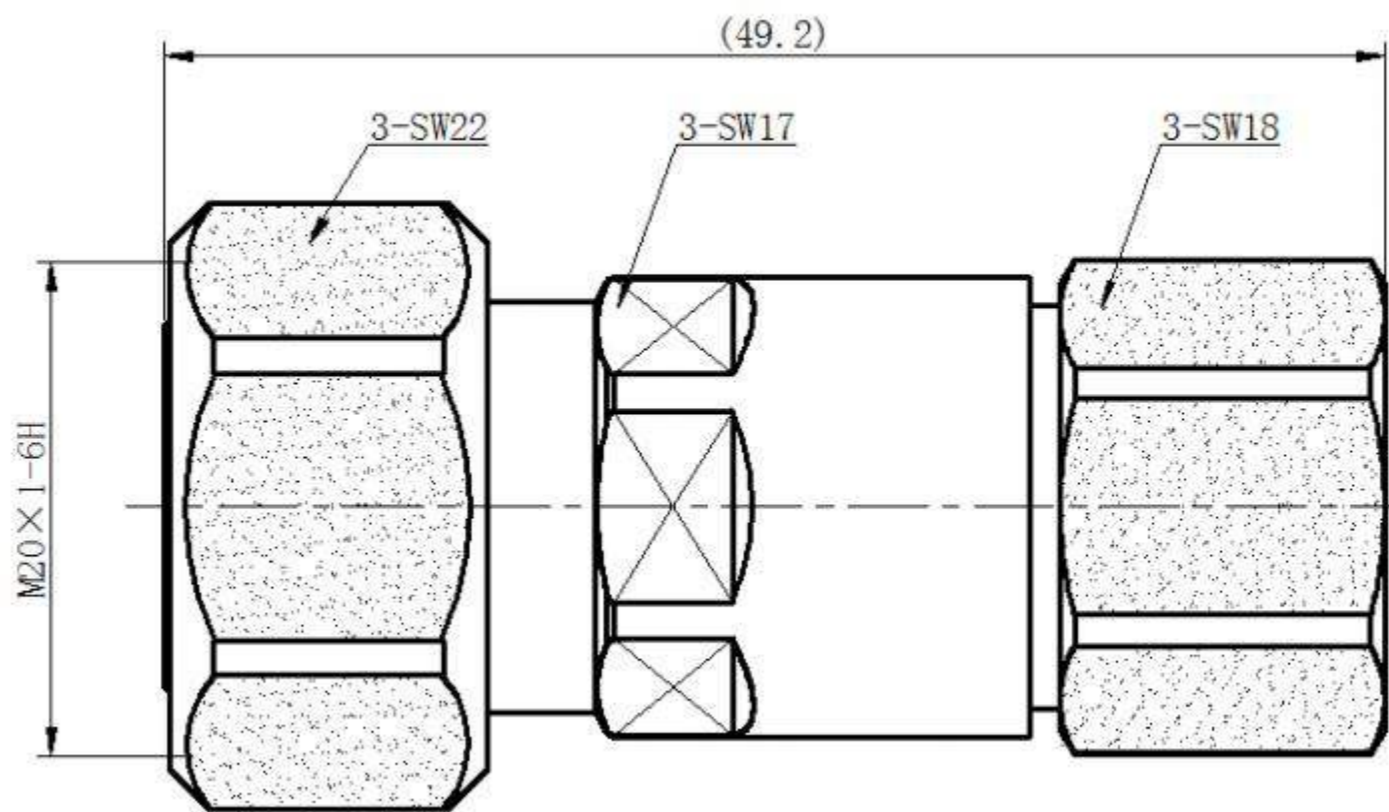

RECOMMENDED CABLE DIMENSION

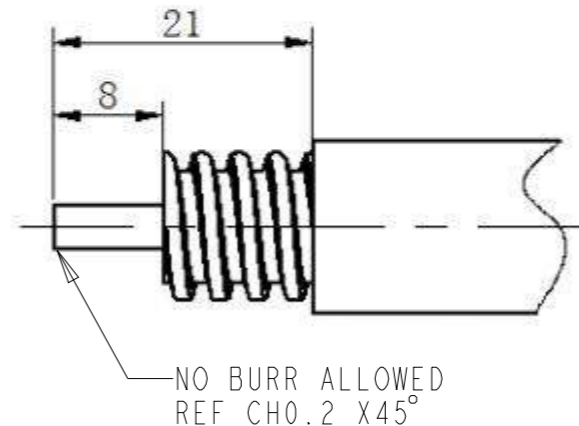

NOTE:

1. INTERFACE ACCORDING TO IEC 61169-54

P/N	PART NAME	MATERIAL	PLATING
2081970-1	CENTER CONTACT	BRONZE	SILVER
	OUTER CONTACT	BRASS	WHITE BRONZE
	INSULATOR	PTFE	
	O-RING	SILICONE RUBBER	
	OTHERS	BRASS	NICKEL

THIS DRAWING IS A CONTROLLED DOCUMENT.		DWN	JZ	10MAR2020						
DIMENSIONS: mm		CHK	RS	10MAR2020						
TOLERANCES UNLESS OTHERWISE SPECIFIED:		APVD	RS	10MAR2020	NAME					
0 PLC ±0.3	1 PLC ±0.2	PRODUCT SPEC	108-115175			4.3-10 STRAIGHT PLUG, SCREW FOR 1/2 SUPERFLEX CABLE CLAMP TYPE				
2 PLC ±0.2	3 PLC ±0.2	APPLICATION SPEC	408-160013			SIZE	CAGE CODE	DRAWING NO	RESTRICTED TO	
4 PLC ±0.2	ANGLES ±	WEIGHT	62.5g			A3	00779	©=2081970	-	
MATERIAL SEE TABLE	FINISH SEE TABLE	CUSTOMER DRAWING			SCALE	1:1	SHEET	1 OF 2	REV	A

REVISIONS

P	LTR	DESCRIPTION	DATE	DWN	APVD

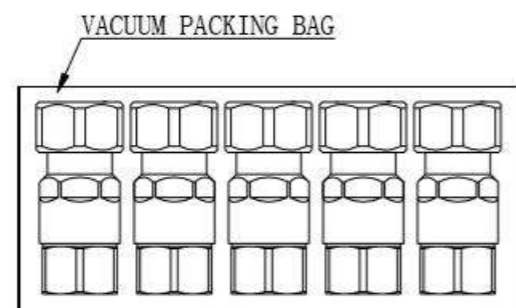

VACUUM PACKING(5PCS/BAG)

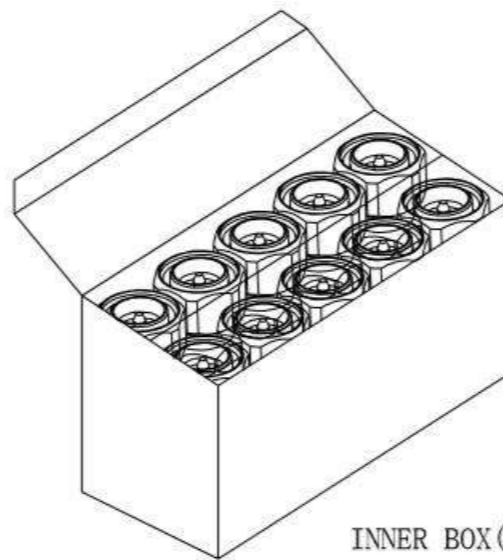

INNER BOX(10PCS/BOX)

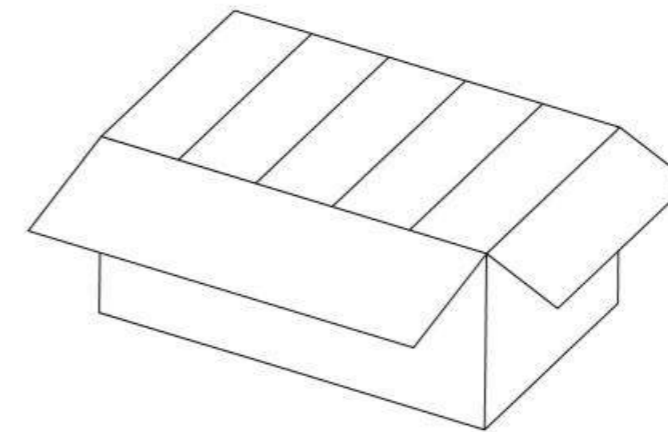

OUTER BOX(150PCS/BOX)

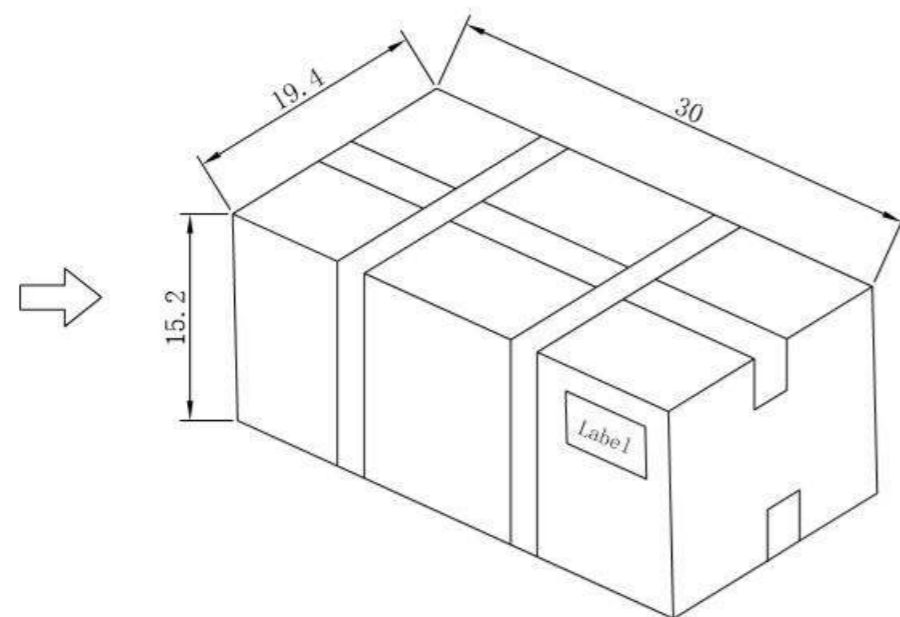

PACKAGE

(BOX SIZE ONLY FOR REFERENCE, UNIT:CM)

THIS DRAWING IS A CONTROLLED DOCUMENT.		DWN JZ	10MAR2020		
DIMENSIONS: mm		CHK RS	10MAR2020		
TOLERANCES UNLESS OTHERWISE SPECIFIED:		APVD RS	10MAR2020	NAME 4.3-10 STRAIGHT PLUG, SCREW FOR 1/2 SUPERFLEX CABLE CLAMP TYPE	
		PRODUCT SPEC	108-115175	RESTRICTED TO	
		APPLICATION SPEC	408-160013	SIZE A3	CAGE CODE 00779
MATERIAL SEE TABLE		WEIGHT	62.5g	DRAWING NO C-2081970	REV A
FINISH SEE TABLE		CUSTOMER DRAWING		SCALE 1:1	SHEET 2 OF 2