

- 1 HOUSING, PLUG: THERMOPLASTIC, UL 94V-0 RATED, BLACK.
CLINCH NUT, FRONT & REAR SHELL: CARBON STEEL.
PIN CONTACT: PHOSPHOR BRONZE.
- 2 PIN CONTACT: GOLD PLATED FOR A LENGTH OF 3.81 [.150] MIN FROM MATING END, 1.27µm [.000050] MIN GOLD IN MATED AREA, 2.54-5.08µm [.000100-.000200] MATTE TIN IN AREA SHOWN, ALL OVER 1.27µm [.000050] MIN NICKEL UNDERPLATE ON ENTIRE CONTACT.
OR
GOLD PLATED FOR A LENGTH OF 3.81 [.150] MIN FROM MATING END, GOLD FLASH OVER PALLADIUM-NICKEL, 1.27µm [.000050] MIN TOTAL IN MATED AREA, 2.54-5.08µm [.000100-.000200] MATTE TIN IN AREA SHOWN, ALL OVER 1.27µm [.000050] MIN NICKEL UNDERPLATE ON ENTIRE CONTACT.
SHELL, REAR: 0.64µm [.000200] MIN TIN OVER 2.54µm [.000100] MIN COPPER.
SHELL, FRONT: 0.64µm [.000200] MIN TIN OVER 2.54µm [.000100] MIN COPPER.
CLINCH NUT: ZINC, CLEAR CHROMATE.

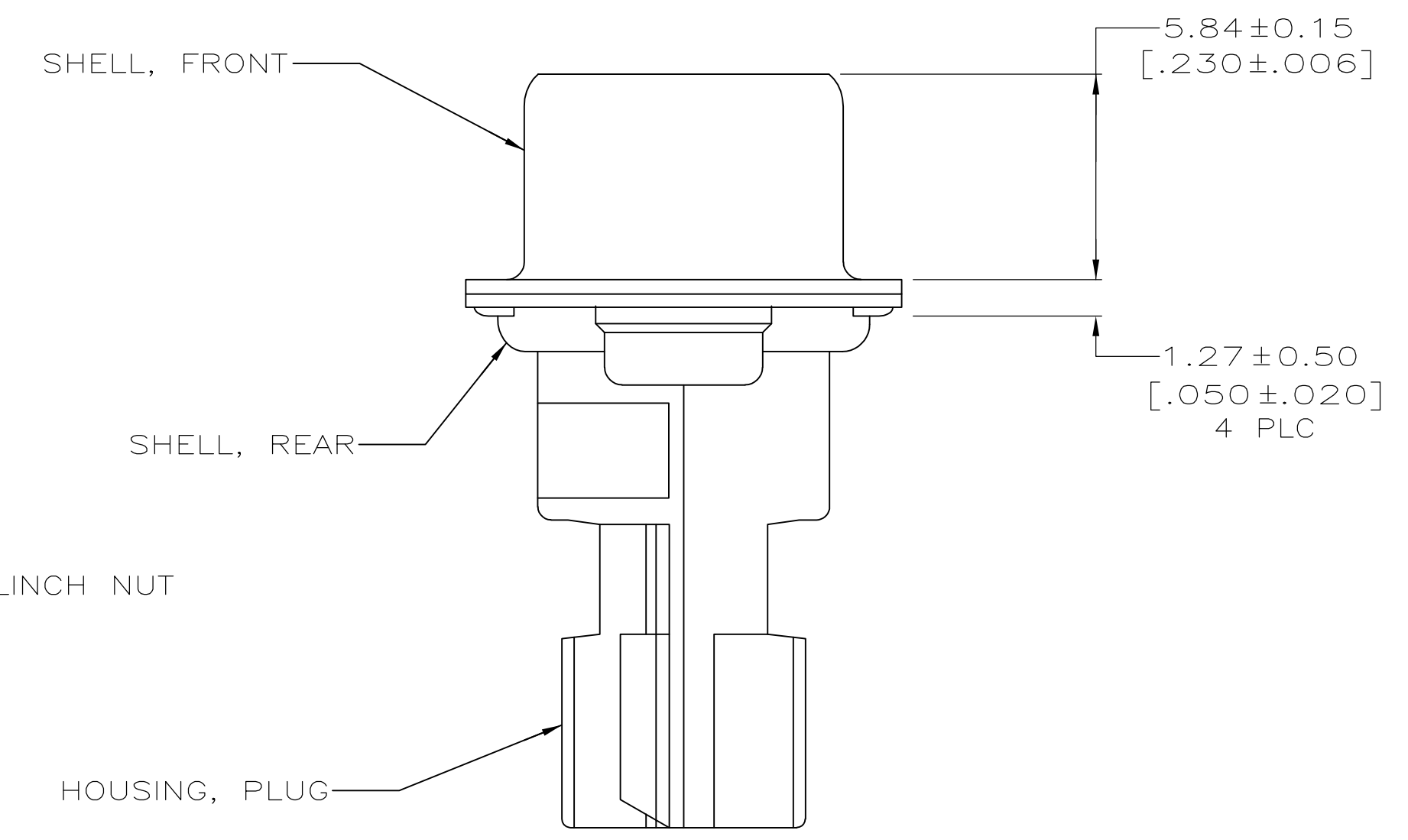
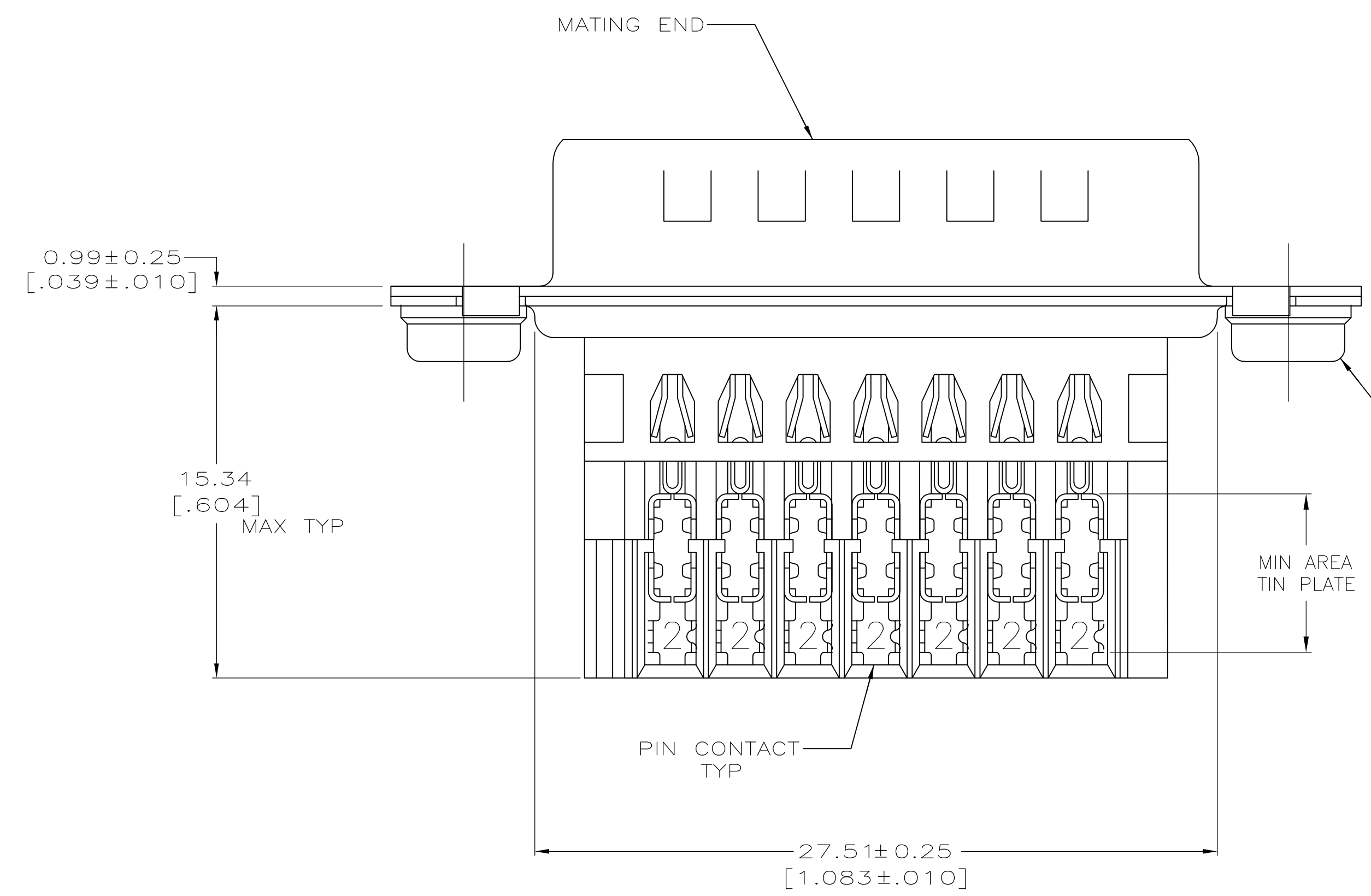

#22-26	5787642-1
AWG WIRE RANGE	PART NO

THIS DRAWING IS A CONTROLLED DOCUMENT.		DWG G. ATTADIA - 11-12-04	Tyco Electronics Corporation Harrisburg, PA 17105-3608	
DIMENSIONS: mm [INCHES]		CHK J. GERACE	APPROD M. WALMSLEY	
TOLERANCES UNLESS OTHERWISE SPECIFIED:		NAME		
0 PLC	± -	PRODUCT SPEC		
1 PLC	± -	108-40011		
2 PLC	± 0.13 [.005]	APPLICATION SPEC		
3 PLC	± -	114-40002		
4 PLC	± -	SIZE CAGE CODE DRAWING NO		
ANGLES	± -	RESTRICTED TO		
FINISH	± -	A1 00779 C=5787642		
MATERIAL		WEIGHT		CUSTOMER DRAWING
		SCALE 6:1		SHEET 1 OF 1 REV B