



## Datasheet Brief

# STDP3150 DisplayPort to VGA Converter

Kinetic Technologies cannot assume responsibility for use of any circuitry other than circuitry entirely embodied in a Kinetic Technologies product. No intellectual property or circuit patent licenses are implied. Kinetic Technologies reserves the right to change the circuitry and specifications without notice at any time.

### Features

- Two lane DisplayPort® 1.2a receiver
- Triple 10-bit video DAC
  - 162 MSPS throughput rate
  - VSIS compatible
  - RGB output with 0 to 700 mV range
- 3.3 V HSYNC, VSYNC
- Resolution through WUXGA
- EDID, MCCS pass-through support
- 3.3 V DDC output signals

- Sink detection logic
- Low power operation – Active 400 mW, standby mode 15 mW
- Package: 64-pin QFN, 6 x 6 mm

### Applications

- DisplayPort to VGA dongle as an attachment to notebook and desktop PCs
- DisplayPort to VGA conversion for notebook and desktop PC motherboard applications

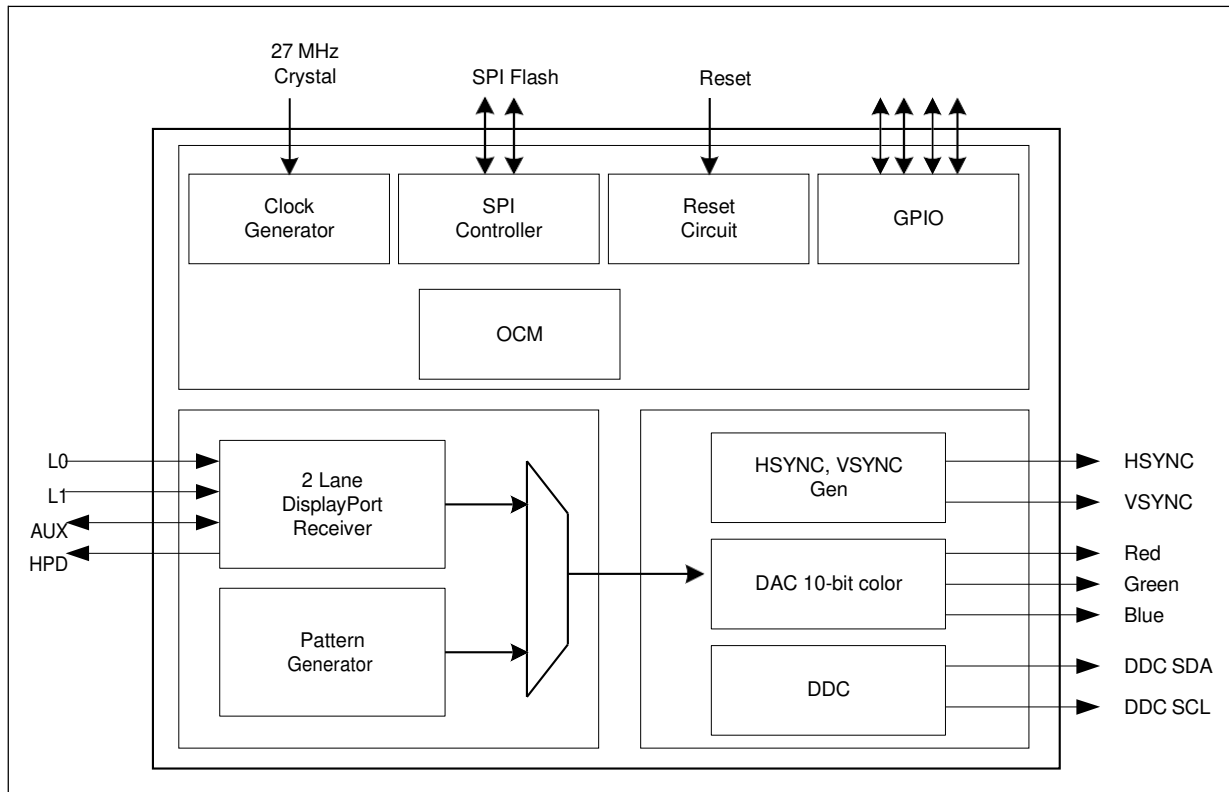

## 1. Description

STDP3150 is a DisplayPort to VGA signal format converter for interfacing DisplayPort based PC, notebook, tablet, and smart phones with conventional VGA displays. DisplayPort offers a unified, scalable, and cost effective interface for embedded and external display applications. As desktop and notebook PCs are increasingly transitioning from conventional analog type interfaces to DisplayPort, STDP3150 facilitates the transition by offering seamless connectivity between new DisplayPort PC, notebooks, and the installed base VGA monitors and projectors. Besides the dongle application, STDP3150 is also a perfect fit for the notebook and desktop motherboard designs based on new generation Intel, AMD CPU/GPU architecture. STDP3150 is a highly integrated converter featuring a DisplayPort receiver, video DAC, clock form generator, test pattern generator, and sink detection block. In addition, STDP3150 includes EDID and MCCS pass-through features, forming a fully transparent operation between the PC and display. Active power consumption of this device is as low as 400 mW, and thus it can be powered by the DisplayPort source when used in a dongle application. The device has a built-in sink detection feature that determines the active and standby state. The device enters into standby (low power) state whenever the VGA cable is disconnected and returns to normal operation when the cable is connected back.

STDP3150 supports video resolutions from VGA through WUXGA. The input DisplayPort interface consists of two main lanes, AUX channel, and HPD signal that maps directly to a standard DisplayPort connector via two layers PCB. The output interface consists of analog R, G, B video, Hsync, Vsync, and DDC signals. Analog video signal amplitude ranges from 0 to 700 mV from a 10-bit video DAC with maximum sampling frequency of 162 MHz. The VGA output signal interface conforms to the VSIS standards with separate Hsync and Vsync control signals. The DDC\_SDA and DDC\_CLK signals are driven from an I2C master, which controls I2C traffic between the DisplayPort AUX channel and external slave device.

## 2. Application overview

Kinetic offers an STDP3150 designers kit with complete reference hardware and firmware.

**Figure 1. System diagram**

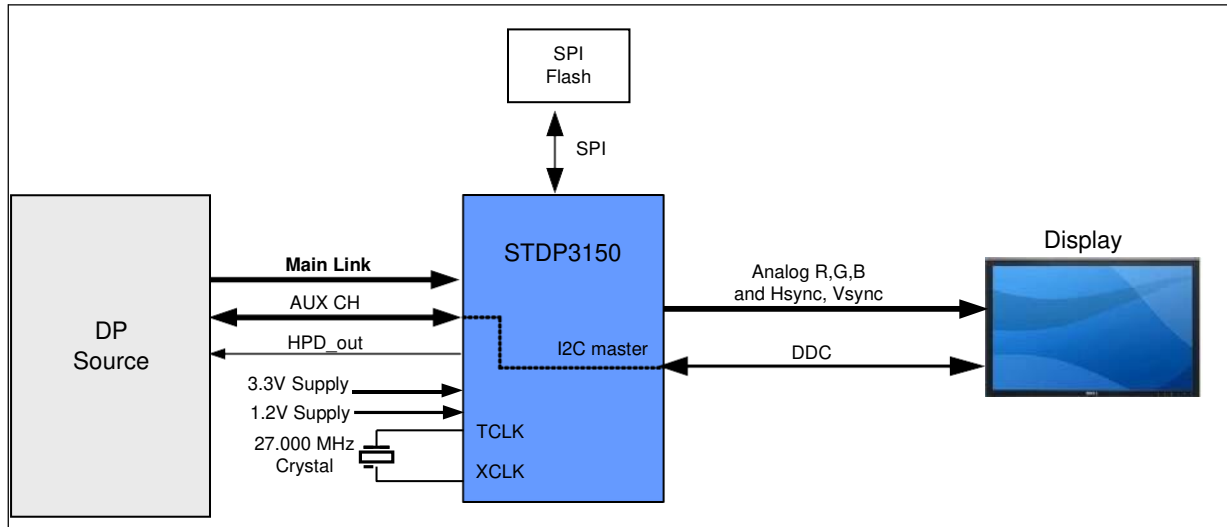

### 3. Ordering information

**Table 1. Order codes**

Part Number	Operating Temperature	Package
STDP3150-AB	0°C to +70°C	64-pin QFN, 6 x 6 mm