

Features

- Frequency range : 32.768 kHz
- SMD : Ceramic package
- External dimensions (mm)
L : 5.05 x W : 1.95 x H : 1.0
- RoHS compliant & Pb free

Applications

- Communication devices
- Measuring equipments
- Consumer products
- Commercial & industrial applications

Electrical Characteristics

Item	Symbol	QT5C	Conditions
Nominal Frequency	f_0	32.768 kHz	
Frequency Tolerance	$\Delta f/f_0$	$\pm 10\text{ppm}, \pm 20\text{ppm}$	at 25°C
Load Capacitance	C_L	6.0pF, 7.0pF, 9.0pF, 12.5pF	
Operating Temperature Range	T_{OTR}	-40°C ~ +85°C	
Storage Temperature Range	T_{STR}	-55°C ~ +125°C	
Turnover Temperature	T_M	25°C \pm 5°C	
Temperature Coefficient	β	-0.034 \pm 0.006ppm/°C ²	
Motional Resistance (ESR)	R_1	70 kΩ Max.	at 25°C
Drive Level	D_L	1 μ W Max.	
Aging	$\Delta f/f_0$	± 3 ppm Max.	at 25°C \pm 3°C, first year
Shunt Capacitance	C_0	1.35 pF Typ.	

Dimensions

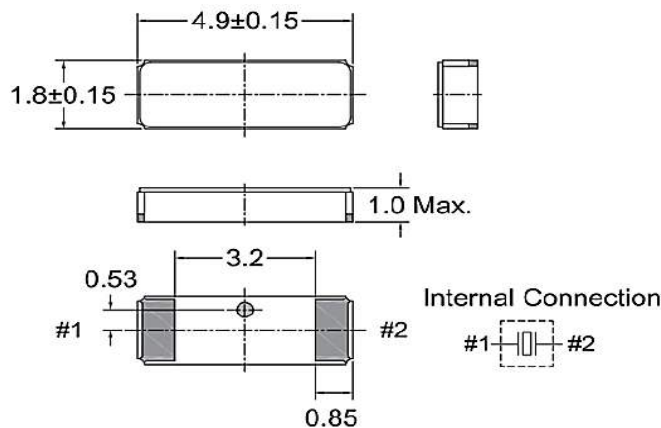

Ordering Information

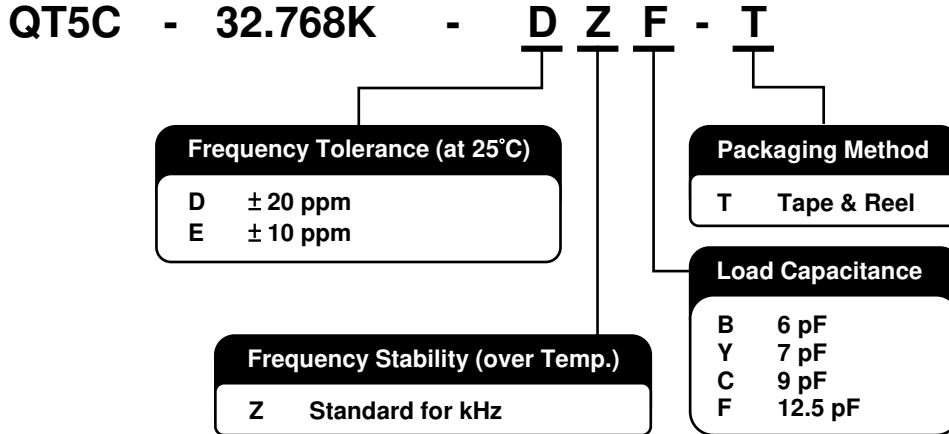

Packing

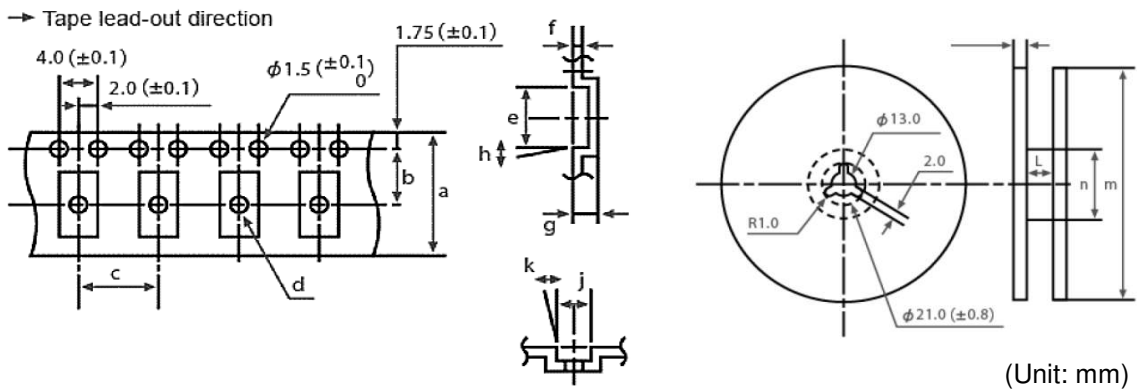

a	b	c	d (φ)	e	f	g	h	j	k	l	m (φ)	n (φ)
12.0	5.5	4.0	1.0	5.3	0.3	1.1	5°	2.1	5°	13.0	180	60

Reflow Profile

