

PRODUCT DATA DRAWING

REVISION HISTORY			
REV	DESCRIPTION	DATE	APPROVED
B	DCN 41727	10/15	DAL

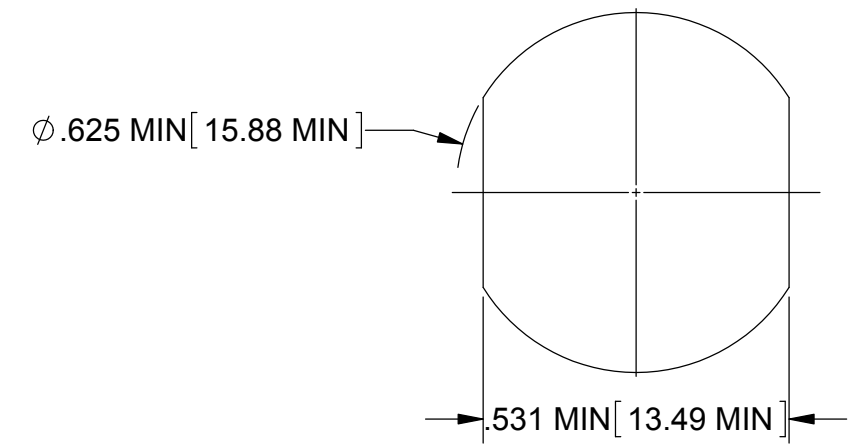
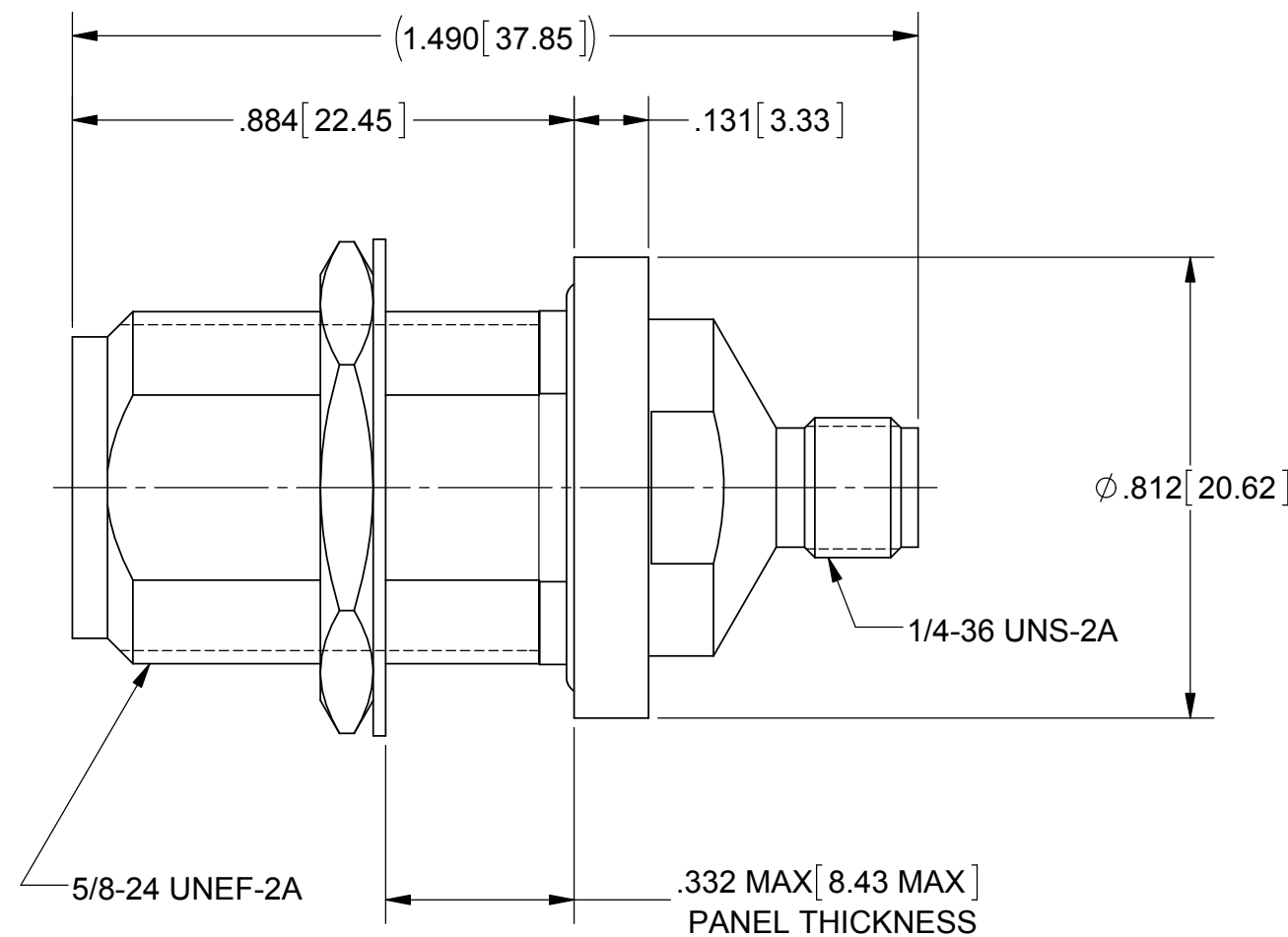
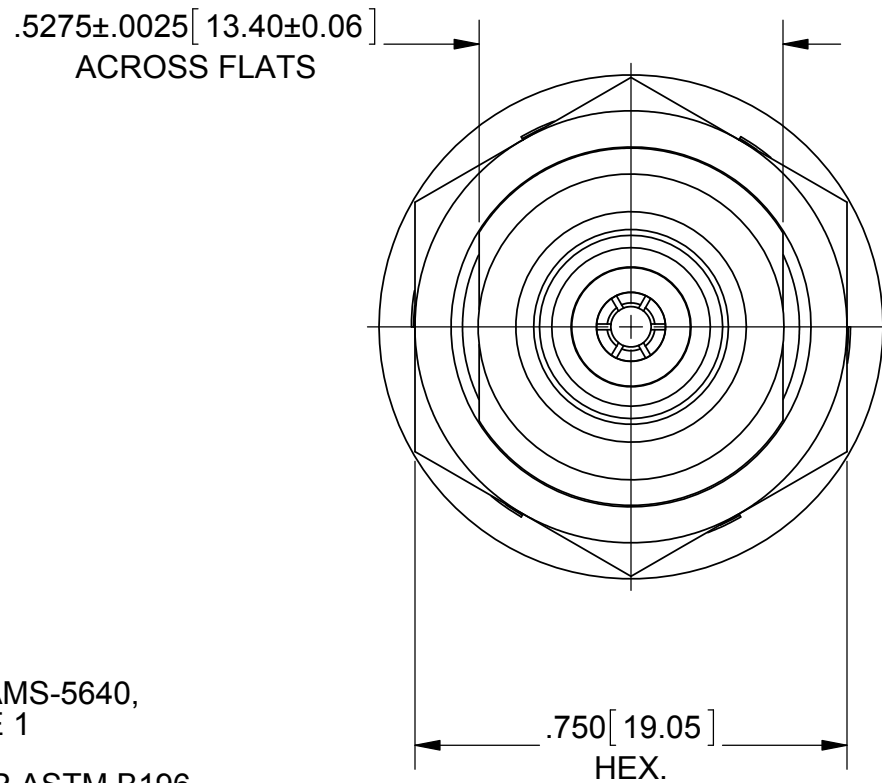
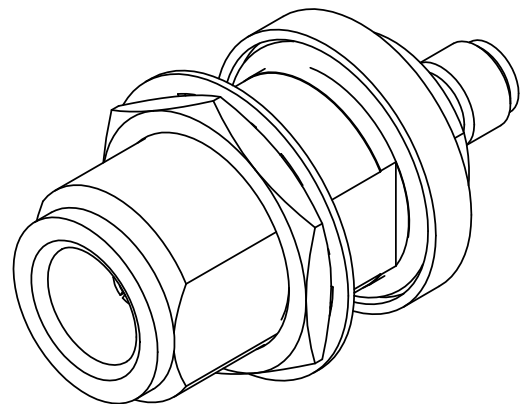

MATERIAL:

BODY, SLEEVE,
LOCK WASHER &
HEX NUT:

STAINLESS STEEL PER AMS-5640,
ALLOY UNS S30300, TYPE 1

CONTACTS:

BERYLLIUM COPPER PER ASTM B196,
ALLOY No. UNS C17300, TD04

INSULATORS::

PTFE PER ASTM D1710, TYPE I, GRADE 1, CLASS B

O-RING:

SILICONE RUBBER PER A-A-59588,
CLASS 2B, GRADE 50/60

GLASS BEAD:

CORNING #7052 OR EQUIVELANT

PIN:

KOVAR PER ASTM F15

FINISH:

BODY, SLEEVE,
LOCK WASHER &
HEX NUT

PASSIVATED PER AMS-2700

CONTACTS:

GO LD PER ASTM B488, TYPE II,
CODE C, CLASS .76, OVER NICKEL
PER AMS-QQ-N-290, CLASS 1, .00005" MIN.

PIN:

NICKEL PER AMS-QQ-N-290, CLASS 1

PERFORMANCE:

IMPEDANCE:
FREQ. RANGE:

50 OHMS
DC TO 18.0 GHz

MATERIAL: SEE NOTES	DIMENSIONS ARE IN INCHES TOLERANCES: FRACTIONAL: ±1/64 ANGULAR: X° ±1'0" X"X' ±15'	UNLESS OTHERWISE SPECIFIED 1) ALL DIMENSIONS ARE IN INCHES (MILLIMETERS) 2) ALL DIMENSIONS ARE AFTER PLATING. 3) BREAK CORNERS & EDGES .005 R. MAX. 4) CHAM. 1ST & LAST THREADS. 5) SURFACE ROUGHNESS 63-MIL-STD-10. 6) DIA.'S ON COMMON CENTERS TO BE CONCENTRIC WITHIN .005 T.I.R. 7) REMOVE ALL BURRS	 2400 Centrepark West Drive, Suite 100 West Palm Beach, FL 33409 TITLE: PN JACK TO SMA JACK, HERMETIC SEAL, BLKHD MT ADAPTER SIZE B CAGE CODE 95077 DWG. NO. SF1104-6007 SCALE: 3:1 SHEET 1 OF 1
FINISH: SEE NOTES	DECIMAL: X ±.030 .XX ±.010 .XXX ±.005	INTERPRET DIMENSIONS AND TOLERANCES PER ASME Y14.5M - 1994	
SURFACE AREA: N/A	THIRD ANGLE PROJECTION	DRAWN: GPF 10/02/15	
PROPRIETARY THE INFORMATION CONTAINED IN THIS DRAWING IS THE SOLE PROPERTY OF SV MICROWAVE, INC. ANY REPRODUCTION IN PART OR AS A WHOLE WITHOUT THE WRITTEN PERMISSION OF SV MICROWAVE, INC IS PROHIBITED.		CHECKED: DAL 10/02/15	
		APPROVED: JM 03/01/79	