

LEAD FINISH (SnPb) ARE IN EOL PROCESS - LAST TIME BUY EXPIRES JUNE 15, 2018

FEATURES:

- First-In/First-Out Dual-Port memory
- 2,048 x 9 organization (IDT7203)
- 4,096 x 9 organization (IDT7204)
- 8,192 x 9 organization (IDT7205)
- 16,384 x 9 organization (IDT7206)
- 32,768 x 9 organization (IDT7207)
- 65,636 x 9 organization (IDT7208)
- High-speed: 12ns access time
- Low power consumption
 - Active: 660mW (max.)
 - Power-down: 44mW (max.)
- Asynchronous and simultaneous read and write
- Fully expandable in both word depth and width
- 720x family is pin and functionally compatible from 256 x 9 to 64k x 9
- Status Flags: Empty, Half-Full, Full
- Retransmit capability
- High-performance CMOS technology
- Military product compliant to MIL-STD-883, Class B
- Standard Military Drawing for #5962-88669 (IDT7203), 5962-89567 (IDT7203), and 5962-89568 (IDT7204) are listed on this function

- Industrial temperature range (–40°C to +85°C) is available (plastic packages only)
- Green parts available, see ordering information

DESCRIPTION:

The IDT7203/7204/7205/7206/7207/7208 are dual-port memory buffers with internal pointers that load and empty data on a first-in/first-out basis. The device uses Full and Empty flags to prevent data overflow and underflow and expansion logic to allow for unlimited expansion capability in both word size and depth.

Data is toggled in and out of the device through the use of the Write (\bar{W}) and Read (\bar{R}) pins.

The device's 9-bit width provides a bit for a control or parity at the user's option. It also features a Retransmit (\bar{RT}) capability that allows the read pointer to be reset to its initial position when \bar{RT} is pulsed LOW. A Half-Full Flag is available in the single device and width expansion modes.

These FIFOs are fabricated using high-speed CMOS technology. They are designed for applications requiring asynchronous and simultaneous read/writes in multiprocessing, rate buffering and other applications.

Military grade product is manufactured in compliance with MIL-STD-883, Class B.

FUNCTIONAL BLOCK DIAGRAM

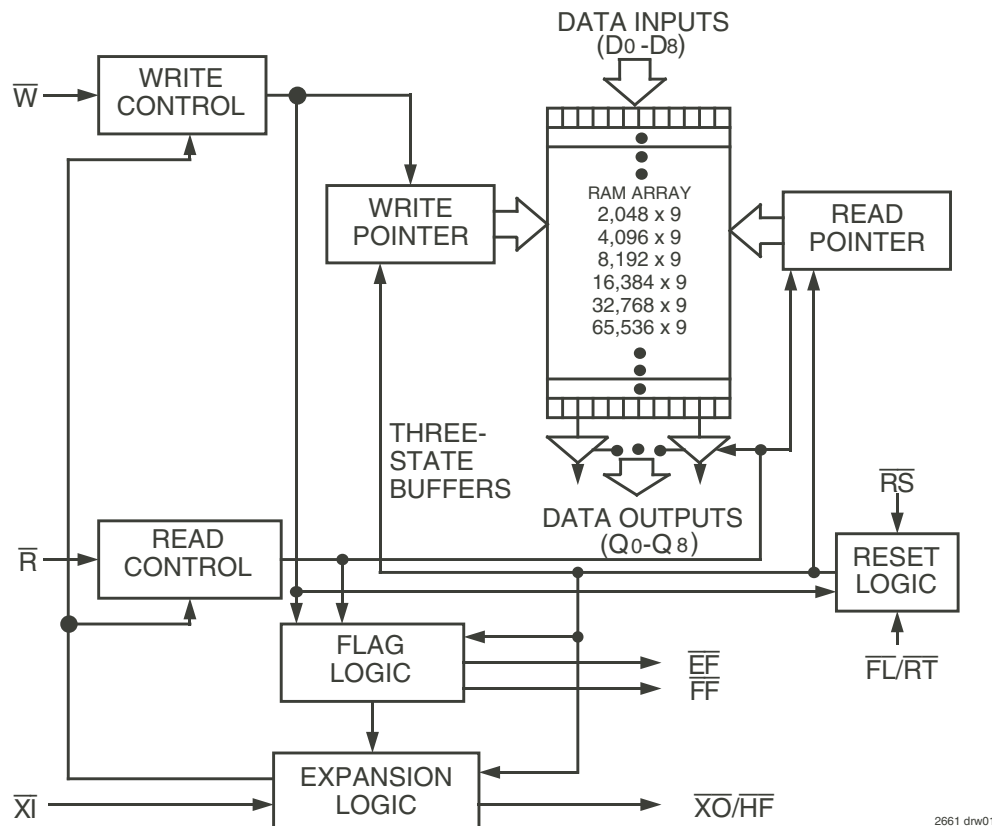

2661 dnv01

PIN CONFIGURATIONS

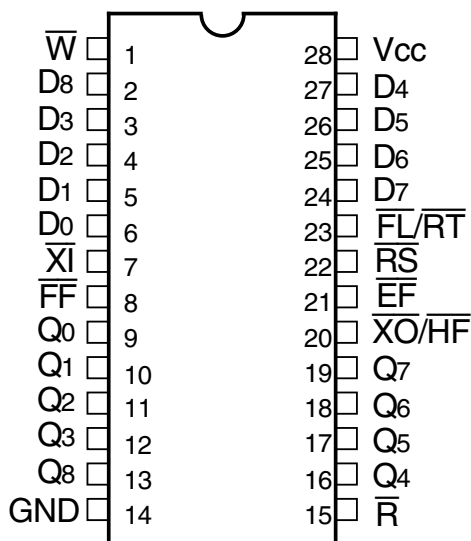

2661 drw02a

TOP VIEW

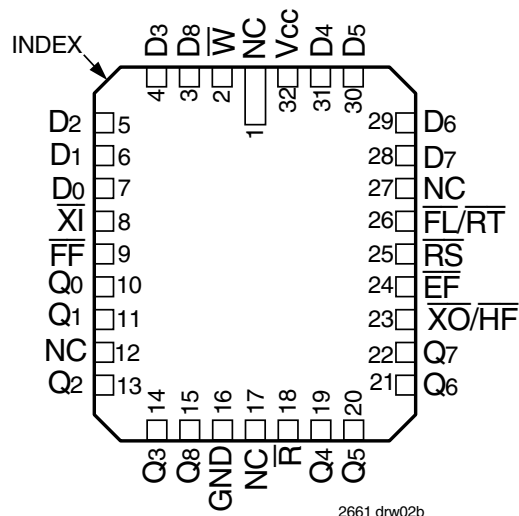

2661 drw02b

TOP VIEW

Package Type	Reference Identifier	Order Code	Device Availability
PLASTIC DIP	P28-1	P	All devices
PLASTIC THIN DIP	P28-2	TP	All except IDT7207/7208
CERDIP	D28-1	D	All except IDT7208
THIN CERDIP	D28-3	TD	Only for IDT7203/7204/7205
SOIC	SO28-3	SO	Only for IDT7204

Package Type	Reference Identifier	Order Code	Device Availability
PLCC	J32-1	J	All devices
LCC ⁽¹⁾	L32-1	L	All except IDT7208

NOTE:

1. This package is only available in the military temperature range.

ABSOLUTE MAXIMUM RATINGS

Symbol	Rating	Com'l & Ind'l	Military	Unit
VTERM	Terminal Voltage with Respect to GND	-0.5 to +7.0	-0.5 to +7.0	V
TSTG	Storage Temperature	-55 to +125	-65 to +155	°C
IOUT	DC Output +Current	-50 to +50	-50 to +50	mA

NOTE:

1. Stresses greater than those listed under ABSOLUTE MAXIMUM RATINGS may cause permanent damage to the device. This is a stress rating only and functional operation of the device at these or any other conditions above those indicated in the operational sections of this specification is not implied. Exposure to absolute maximum rating conditions for extended periods may affect reliability.

RECOMMENDED DC OPERATING CONDITIONS

Symbol	Parameter	Min.	Typ.	Max.	Unit
Vcc	Supply Voltage Commercial/Industrial/Military	4.5	5.0	5.5	V
GND	Supply Voltage	0	0	0	V
V _{IH} ⁽¹⁾	Input High Voltage Commercial/Industrial	2.0	—	—	V
V _{IH} ⁽¹⁾	Input High Voltage Military	2.2	—	—	V
V _{IL} ⁽²⁾	Input Low Voltage Commercial/Industrial/Military	—	—	0.8	V
T _A	Operating Temperature Commercial	0	—	70	°C
T _A	Operating Temperature Industrial	-40	—	85	°C
T _A	Operating Temperature Military	-55	—	125	°C

NOTES:

- For $\overline{RT}/\overline{RS}/\overline{XI}$ input, V_{IH} = 2.6V (commercial).
For $\overline{RT}/\overline{RS}/\overline{XI}$ input, V_{IH} = 2.6V (military).
- 1.5V undershoots are allowed for 10ns once per cycle.

DC ELECTRICAL CHARACTERISTICS

(Commercial: $V_{CC} = 5V \pm 10\%$, $T_A = 0^\circ C$ to $+70^\circ C$; Industrial: $V_{CC} = 5V \pm 10\%$, $T_A = -40^\circ C$ to $+85^\circ C$; Military: $V_{CC} = 5V \pm 10\%$, $T_A = -55^\circ C$ to $+125^\circ C$)

Symbol	Parameter	IDT7203 ⁽¹⁾ IDT7204 ⁽¹⁾ Commercial and Industrial $t_A = 12, 15, 20, 25, 35, 50$ ns			IDT7203 IDT7204 Military ⁽³⁾ $t_A = 20, 30, 40$ ns			Unit
		Min.	Typ.	Max.	Min.	Typ.	Max.	
$I_{L1}^{(6)}$	Input Leakage Current (Any Input)	-1	—	1	-1	—	1	μA
$I_{LO}^{(7)}$	Output Leakage Current	-10	—	10	-10	—	10	μA
V_{OH}	Output Logic "1" Voltage $I_{OH} = -2$ mA	2.4	—	—	2.4	—	—	V
V_{OL}	Output Logic "0" Voltage $I_{OL} = 8$ mA	—	—	0.4	—	—	0.4	V
$I_{CC1}^{(8,9,10)}$	Active Power Supply Current	—	—	120	—	—	150	mA
$I_{CC2}^{(8,10,11)}$	Standby Current ($\overline{R}=\overline{W}=\overline{RS}=\overline{FL}/\overline{RT}=V_{IH}$)	—	—	12	—	—	25	mA
$I_{CC3}^{(8,10,12)}$	Power Down Current	—	—	2	—	—	4	mA

Symbol	Parameter	IDT7205 ⁽¹⁾ IDT7206 ^(2,4) IDT7207 ^(2,4) IDT7208 ^(2,5) Commercial and Industrial $t_A = 12, 15, 20, 25, 35, 50$ ns			IDT7205 IDT7206 IDT7207 Military $t_A = 20, 30$ ns			Unit
		Min.	Typ.	Max.	Min.	Typ.	Max.	
$I_{L1}^{(6)}$	Input Leakage Current (Any Input)	-1	—	1	-1	—	1	μA
$I_{LO}^{(7)}$	Output Leakage Current	-10	—	10	-10	—	10	μA
V_{OH}	Output Logic "1" Voltage $I_{OH} = -2$ mA	2.4	—	—	2.4	—	—	V
V_{OL}	Output Logic "0" Voltage $I_{OL} = 8$ mA	—	—	0.4	—	—	0.4	V
$I_{CC1}^{(8,9,10)}$	Active Power Supply Current	—	—	120	—	—	150	mA
$I_{CC2}^{(8,10,11)}$	Standby Current ($\overline{RS}=\overline{FL}/\overline{RT}=V_{IH}$)	—	—	12	—	—	25	mA
$I_{CC3}^{(8,10,12)}$	Power Down Current	—	—	8	—	—	12	mA

NOTES:

- Industrial temperature range product for 15ns and 25ns speed grades are available as a standard device.
- Industrial temperature range product for 25ns speed grade only is available as a standard device. All other speed grades are available by special order.
- Military temperature range product for the 40ns is only available for 7203.
- Commercial temperature range product for the 12ns not available.
- Commercial temperature range product for the 12ns, 15ns and 50ns not available.
- Measurements with $0.4 \leq V_{IN} \leq V_{CC}$.
- $\overline{R} \geq V_{IH}$, $0.4 \leq V_{OUT} \leq V_{CC}$.
- Tested with outputs open ($I_{OUT} = 0$).
- \overline{R} and \overline{W} toggle at 20 MHz and data inputs switch at 10 MHz.
- I_{CC} measurements are made with outputs open.
- All Inputs = $V_{CC} - 0.2V$ or $GND + 0.2V$, except \overline{R} and \overline{W} , which toggle at 20MHz.
- All Inputs = $V_{CC} - 0.2V$ or $GND + 0.2V$, except \overline{R} and $\overline{W} = V_{CC} - 0.2V$.

AC TEST CONDITIONS

Input Pulse Levels	GND to 3.0V
Input Rise/Fall Times	5ns
Input Timing Reference Levels	1.5V
Output Reference Levels	1.5V
Output Load	See Figure 1

CAPACITANCE⁽¹⁾ ($T_A = +25^\circ C$, $f = 1.0$ MHz)

Symbol	Parameter	Condition	Max.	Unit
$C_{IN}^{(1)}$	Input Capacitance	$V_{IN} = 0V$	10	pF
$C_{OUT}^{(1,2)}$	Output Capacitance	$V_{OUT} = 0V$	10	pF

NOTES:

- This parameter is sampled and not 100% tested.
- With output deselected.

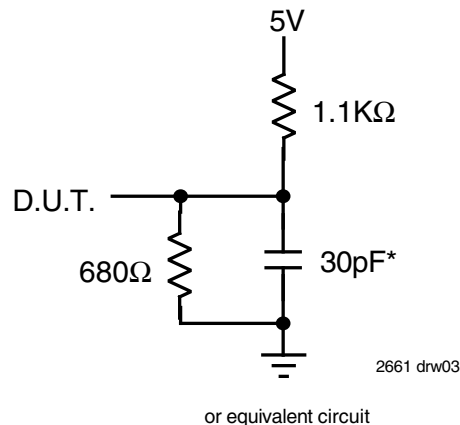

Figure 1. Output Load
*Includes jig and scope capacitances.

AC ELECTRICAL CHARACTERISTICS⁽¹⁾

(Commercial: VCC = 5V ± 10%, TA = 0°C to +70°C; Industrial: VCC = 5V ± 10%, TA = -40°C to +85°C; Military: VCC = 5V ± 10%, TA = -55°C to +125°C)

Symbol	Parameters	Commercial		Com'I & Ind'I		Com'I & Military		Commercial		Com'I & Ind'I		Unit
		Min.	Max.	Min.	Max.	Min.	Max.	Min.	Max.	Min.	Max.	
				Commercial	Com'I & Ind'I	Com'I & Military	Commercial	Com'I & Ind'I				
				IDT7203L12	IDT7203L15 ⁽²⁾	IDT7203L20	IDT7208L20	IDT7203L25 ⁽²⁾				
				IDT7204L12	IDT7204L15 ⁽²⁾	IDT7204L20		IDT7204L25 ⁽²⁾				
				IDT7205L12	IDT7205L15 ⁽²⁾	IDT7205L20		IDT7205L25 ⁽²⁾				
					IDT7206L15	IDT7206L20		IDT7206L25 ⁽³⁾				
					IDT7207L15	IDT7207L20		IDT7207L25 ⁽³⁾				
								IDT7208L25 ⁽³⁾				
fs	Shift Frequency	—	50	—	40	—	33.3	—	33.3	—	28.5	MHz
tRC	Read Cycle Time	20	—	25	—	30	—	30	—	35	—	ns
tA	Access Time	—	12	—	15	—	20	—	20	—	25	ns
tRR	Read Recovery Time	8	—	10	—	10	—	10	—	10	—	ns
tRPW	Read Pulse Width ⁽⁴⁾	12	—	15	—	20	—	20	—	25	—	ns
tRLZ	Read LOW to Data Bus LOW ⁽⁵⁾	3	—	5	—	5	—	5	—	5	—	ns
tWLZ	Write HIGH to Data Bus Low-Z ^(5,6)	3	—	5	—	5	—	5	—	5	—	ns
tDV	Data Valid from Read HIGH	5	—	5	—	5	—	5	—	5	—	ns
tRHZ	Read HIGH to Data Bus High-Z ⁽⁵⁾	—	12	—	15	—	15	—	15	—	18	ns
tWC	Write Cycle Time	20	—	25	—	30	—	30	—	35	—	ns
tWPW	Write Pulse Width ⁽⁴⁾	12	—	15	—	20	—	20	—	25	—	ns
tWR	Write Recovery Time	8	—	10	—	10	—	10	—	10	—	ns
tDS	Data Set-up Time	9	—	11	—	12	—	12	—	15	—	ns
tDH	Data Hold Time	0	—	0	—	0	—	0	—	0	—	ns
tRSC	Reset Cycle Time	20	—	25	—	30	—	30	—	35	—	ns
tRS	Reset Pulse Width ⁽⁴⁾	12	—	15	—	20	—	20	—	25	—	ns
tRSS	Reset Set-up Time ⁽⁵⁾	12	—	15	—	20	—	20	—	25	—	ns
tRTR	Reset Recovery Time	8	—	10	—	10	—	10	—	10	—	ns
tRTC	Retransmit Cycle Time	20	—	25	—	30	—	30	—	35	—	ns
tRT	Retransmit Pulse Width ⁽⁴⁾	12	—	15	—	20	—	20	—	25	—	ns
tRTS	Retransmit Set-up Time ⁽⁵⁾	12	—	15	—	20	—	20	—	25	—	ns
tRTR	Retransmit Recovery Time	8	—	10	—	10	—	10	—	10	—	ns
tEFL	Reset to \overline{EF} LOW	—	12	—	25	—	30	—	30	—	35	ns
tHFH, tFFH	Reset to \overline{HF} and \overline{FF} HIGH	—	17	—	25	—	30	—	30	—	35	ns
tRTF	Retransmit LOW to Flags Valid	—	20	—	25	—	30	—	30	—	35	ns
tREF	Read LOW to \overline{EF} LOW	—	12	—	15	—	20	—	20	—	25	ns
tRFF	Read HIGH to \overline{FF} HIGH	—	14	—	15	—	20	—	20	—	25	ns
tRPE	Read Pulse Width after \overline{EF} HIGH	12	—	15	—	20	—	20	—	25	—	ns
tWEF	Write HIGH to \overline{EF} HIGH	—	12	—	15	—	20	—	20	—	25	ns
tWFF	Write LOW to \overline{FF} LOW	—	14	—	15	—	20	—	20	—	25	ns
tWHF	Write LOW to \overline{HF} Flag LOW	—	17	—	25	—	30	—	30	—	35	ns
tRHF	Read HIGH to \overline{HF} Flag HIGH	—	17	—	25	—	30	—	30	—	35	ns
tWPF	Write Pulse Width after \overline{FF} HIGH	12	—	15	—	20	—	20	—	25	—	ns
tXOL	Read/Write LOW to \overline{XO} LOW	—	12	—	15	—	20	—	20	—	25	ns
tXOH	Read/Write HIGH to \overline{XO} HIGH	—	12	—	15	—	20	—	20	—	25	ns
tXI	\overline{XI} Pulse Width ⁽⁴⁾	12	—	15	—	20	—	20	—	25	—	ns
tXIR	\overline{XI} Recovery Time	8	—	10	—	10	—	10	—	10	—	ns
tXIS	\overline{XI} Set-up Time	8	—	10	—	10	—	10	—	10	—	ns

NOTES:

1. Timings referenced as in AC Test Conditions.
2. Industrial temperature range product for 15ns and 25ns speed grades are available as a standard device.
3. Industrial temperature range product for 25ns speed grade only is available as a standard device. All other speed grades are available by special order.
4. Pulse widths less than minimum are not allowed.
5. Values guaranteed by design, not currently tested.
6. Only applies to read data flow-through mode.

SIGNAL DESCRIPTIONS

INPUTS:

DATA IN (D0–D8) — Data inputs for 9-bit wide data.

CONTROLS:

RESET (\overline{RS}) — Reset is accomplished whenever the Reset (\overline{RS}) input is taken to a LOW state. During reset, both internal read and write pointers are set to the first location. A reset is required after power-up before a write operation can take place. Both the Read Enable (\overline{R}) and Write Enable (\overline{W}) inputs must be in the HIGH state during the window shown in Figure 2 (i.e. t_{RSS} before the rising edge of \overline{RS}) and should not change until t_{RSR} after the rising edge of \overline{RS} .

WRITE ENABLE (\overline{W}) — A write cycle is initiated on the falling edge of this input if the Full Flag (\overline{FF}) is not set. Data set-up and hold times must be adhered to, with respect to the rising edge of the Write Enable (\overline{W}). Data is stored in the RAM array sequentially and independently of any on-going read operation.

After half of the memory is filled, and at the falling edge of the next write operation, the Half-Full Flag (\overline{HF}) will be set to LOW, and will remain set until the difference between the write pointer and read pointer is less than or equal to one-half of the total memory of the device. The Half-Full Flag (\overline{HF}) is then reset by the rising edge of the read operation.

To prevent data overflow, the Full Flag (\overline{FF}) will go LOW on the falling edge of the last write signal, which inhibits further write operations. Upon the completion of a valid read operation, the Full Flag (\overline{FF}) will go HIGH after t_{RFF} , allowing a new valid write to begin. When the FIFO is full, the internal write pointer is blocked from \overline{W} , so external changes in \overline{W} will not affect the FIFO when it is full.

READENABLE (\overline{R}) — A read cycle is initiated on the falling edge of the Read Enable (\overline{R}), provided the Empty Flag (\overline{EF}) is not set. The data is accessed on a First-In/First-Out basis, independent of any ongoing write operations. After Read Enable (\overline{R}) goes HIGH, the Data Outputs (Q0 through Q8) will return to a high-impedance condition until the next Read operation. When all the data has been read from the FIFO, the Empty Flag (\overline{EF}) will go LOW, allowing the “final” read cycle but inhibiting further read operations, with the data outputs remaining in a high-impedance state. Once a valid write operation has been accomplished, the Empty Flag (\overline{EF}) will go HIGH after t_{WEF} and a valid Read can then begin. When the FIFO is empty, the internal read pointer is blocked from \overline{R} so external changes will not affect the FIFO when it is empty.

FIRST LOAD/RETRANSMIT ($\overline{FL/RT}$) — This is a dual-purpose input. In the Depth Expansion Mode, this pin is grounded to indicate that it is the first device

loaded (see Operating Modes). The Single Device Mode is initiated by grounding the Expansion In (\overline{XI}).

The IDT7203/7204/7205/7206/7207/7208 can be made to retransmit data when the Retransmit Enable Control (\overline{RT}) input is pulsed LOW. A retransmit operation will set the internal read pointer to the first location and will not affect the write pointer. The status of the Flags will change depending on the relative locations of the read and write pointers. Read Enable (\overline{R}) and Write Enable (\overline{W}) must be in the HIGH state during retransmit. This feature is useful when less than 2,048/4,096/8,192/16,384/32,768/65,536 writes are performed between resets. The retransmit feature is not compatible with the Depth Expansion Mode.

EXPANSION IN (\overline{XI}) — This input is a dual-purpose pin. Expansion In (\overline{XI}) is grounded to indicate an operation in the single device mode. Expansion In (\overline{XI}) is connected to Expansion Out (\overline{XO}) of the previous device in the Depth Expansion or Daisy-Chain Mode.

OUTPUTS:

FULL FLAG (\overline{FF}) — The Full Flag (\overline{FF}) will go LOW, inhibiting further write operations, when the device is full. If the read pointer is not moved after Reset (\overline{RS}), the Full Flag (\overline{FF}) will go LOW after 2,048/4,096/8,192/16,384/32,768/65,536 writes.

EMPTY FLAG (\overline{EF}) — The Empty Flag (\overline{EF}) will go LOW, inhibiting further read operations, when the read pointer is equal to the write pointer, indicating that the device is empty.

EXPANSION OUT/HALF-FULL FLAG ($\overline{XO/HF}$) — This is a dual-purpose output. In the single device mode, when Expansion In (\overline{XI}) is grounded, this output acts as an indication of a half-full memory.

After half of the memory is filled, and at the falling edge of the next write operation, the Half-Full Flag (\overline{HF}) will be set to LOW and will remain set until the difference between the write pointer and read pointer is less than or equal to one-half of the total memory of the device. The Half-Full Flag (\overline{HF}) is then reset by the rising edge of the read operation.

In the Depth Expansion Mode, Expansion In (\overline{XI}) is connected to Expansion Out (\overline{XO}) of the previous device. This output acts as a signal to the next device in the Daisy Chain by providing a pulse to the next device when the previous device reaches the last location of memory. There will be an \overline{XO} pulse when the Write pointer reaches the last location of memory, and an additional \overline{XO} pulse when the Read pointer reaches the last location of memory.

DATA OUTPUTS (Q0–Q8) — Q0–Q8 are data outputs for 9-bit wide data. These outputs are in a high-impedance condition whenever Read (\overline{R}) is in a HIGH state.

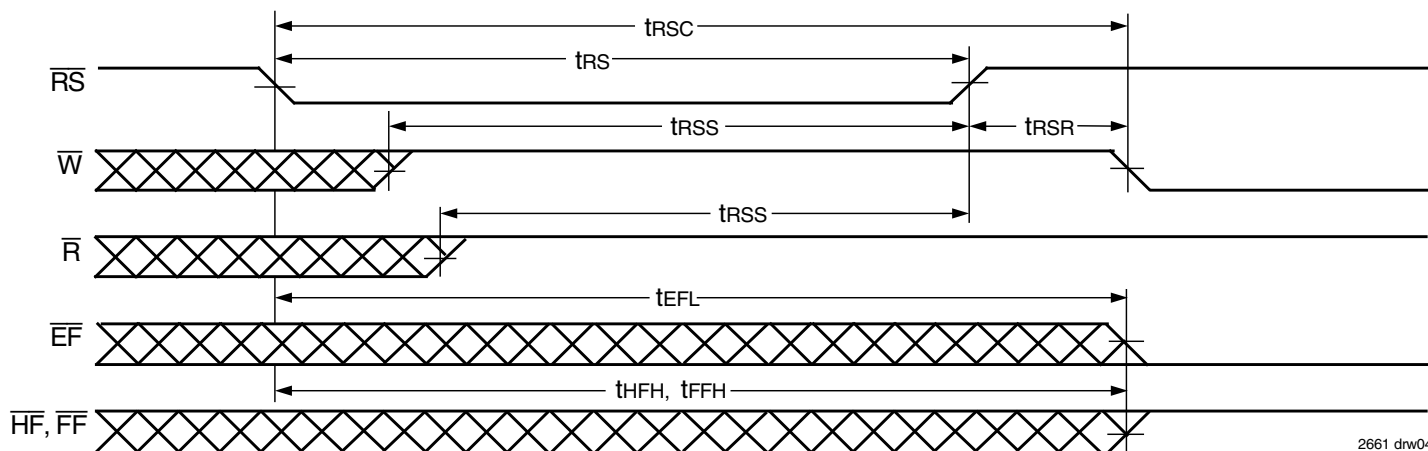

2661 drw04

NOTE:
 1. \bar{W} and $\bar{R} = V_{IH}$ around the rising edge of \bar{RS} .

Figure 2. Reset

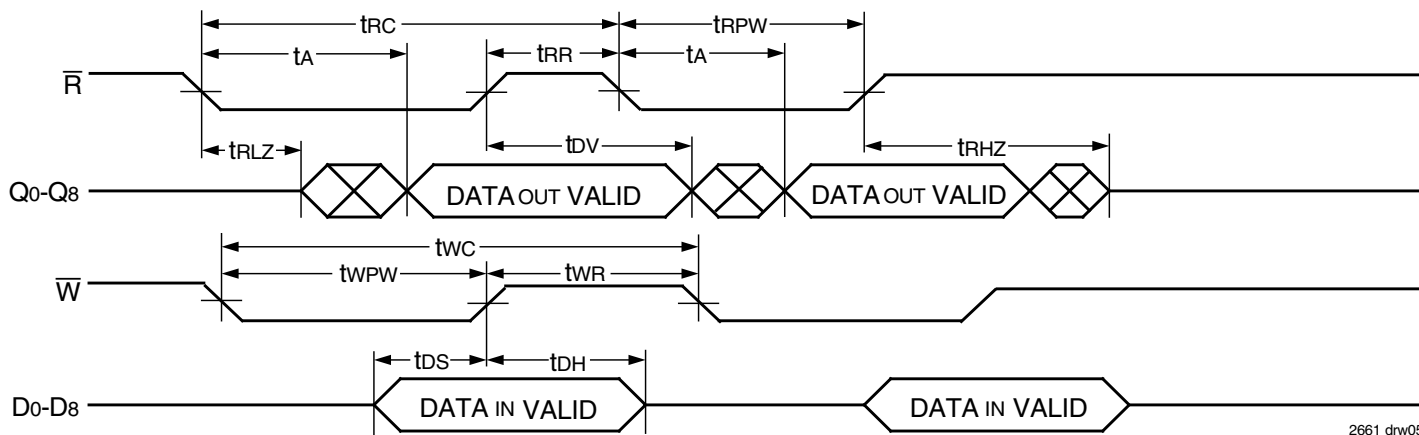

2661 drw05

Figure 3. Asynchronous Write and Read Operation

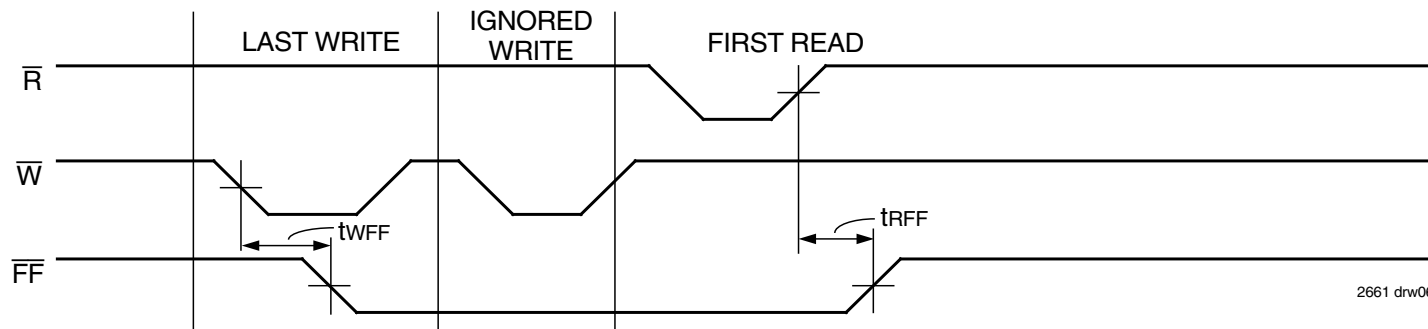

2661 drw06

Figure 4. Full Flag Timing From Last Write to First Read

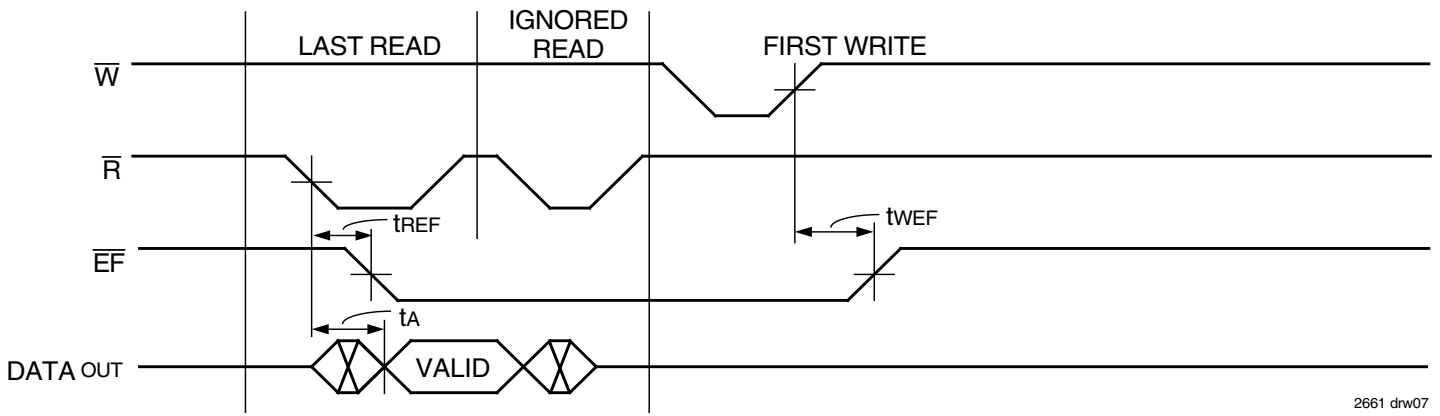
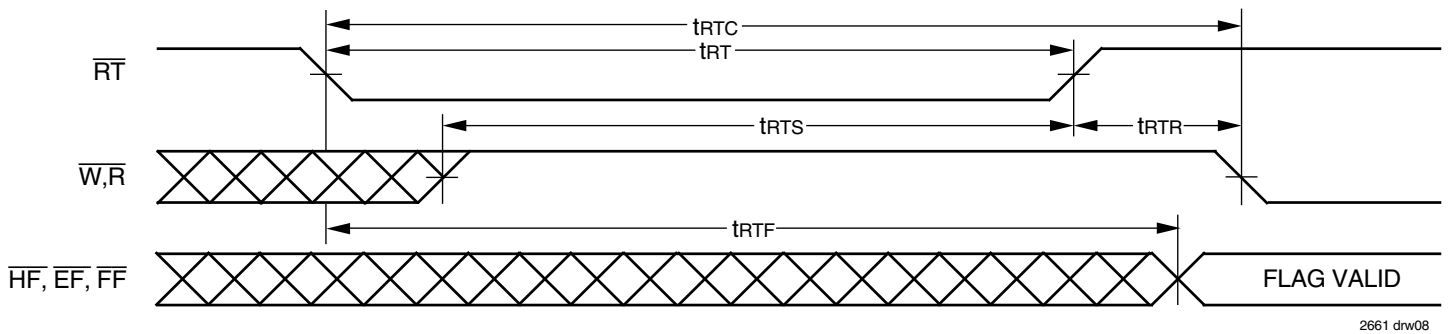

Figure 5. Empty Flag Timing From Last Read to First Write

2661 drw07



NOTE:

- \bar{EF} , \bar{FF} and \bar{HF} may change status during Retransmit, but flags will be valid at t_{RTC} .

Figure 6. Retransmit

2661 drw08

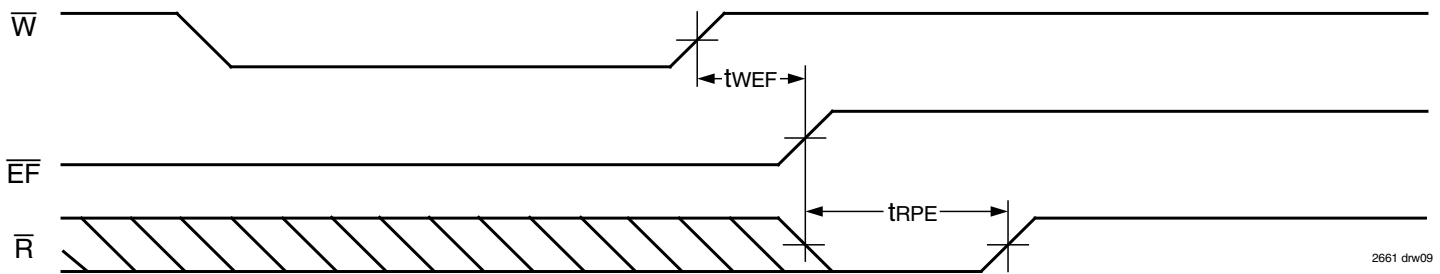

Figure 7. Minimum Timing for an Empty Flag Coincident Read Pulse.

2661 drw09

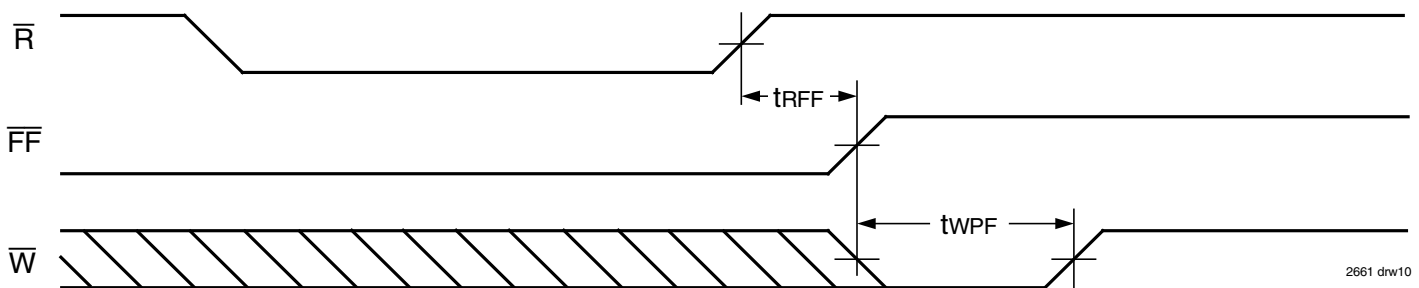

Figure 8. Minimum Timing for a Full Flag Coincident Write Pulse.

2661 drw10

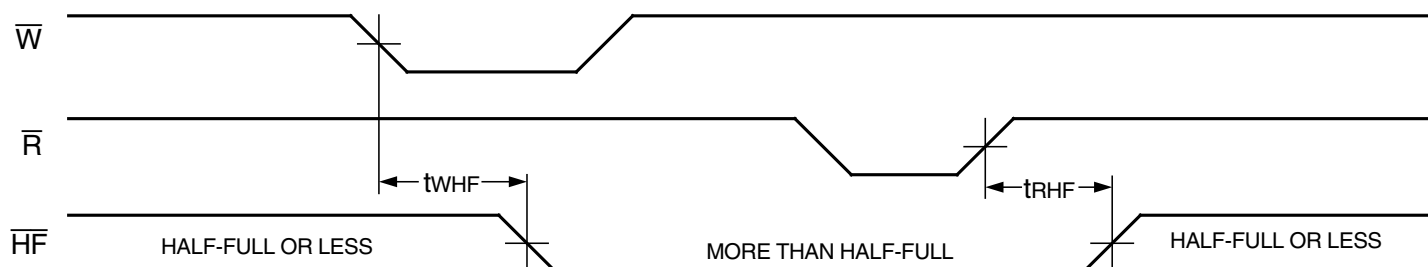

Figure 9. Half-Full Flag Timing

2661 drw11

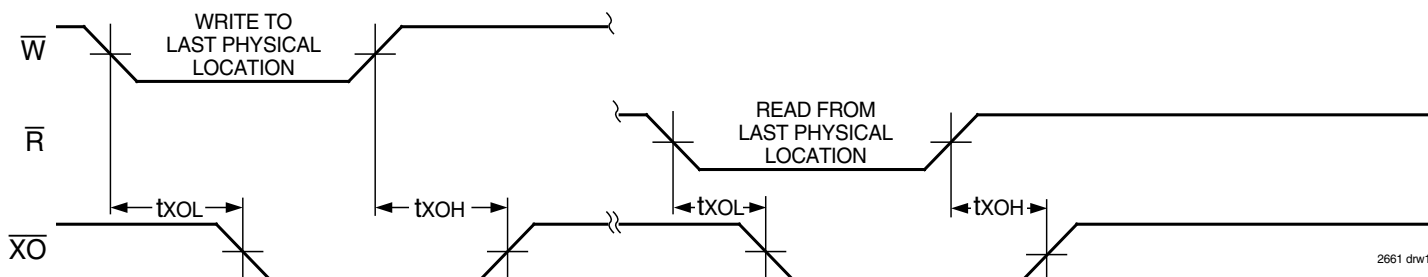

Figure 10. Expansion Out

2661 drw12

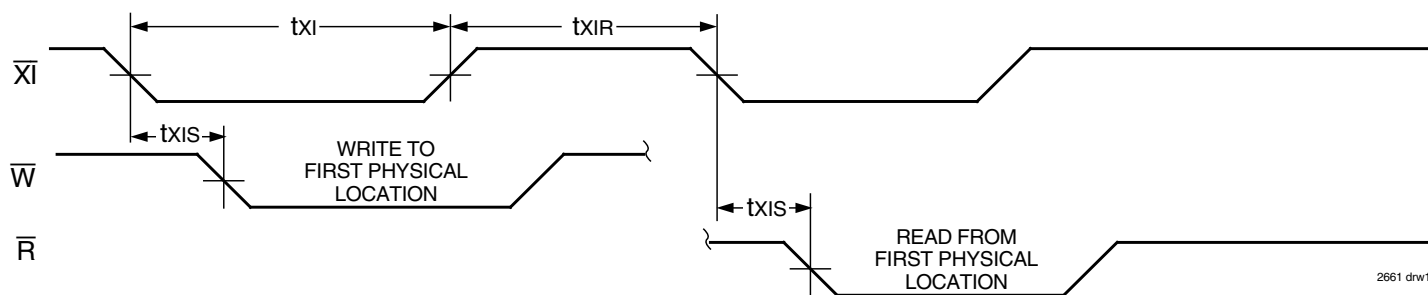

Figure 11. Expansion In

2661 drw13

OPERATING MODES:

Care must be taken to assure that the appropriate flag is monitored by each system (i.e. \overline{FF} is monitored on the device where \overline{W} is used; \overline{EF} is monitored on the device where \overline{R} is used). For additional information on the IDT7203/7204/7205/7206/7207, refer to Tech Note 8: *Operating FIFOs on Full and Empty Boundary Conditions* and Tech Note 6: *Designing with FIFOs*.

Single Device Mode

A single IDT7203/7204/7205/7206/7207/7208 may be used when the application requirements are for 2,048/4,096/8,192/16,384/32,768/65,536 words or less. These FIFOs are in a Single Device Configuration when the Expansion In (\overline{XI}) control input is grounded (see Figure 12).

Depth Expansion

These FIFOs can easily be adapted to applications when the requirements are for greater than 2,048/4,096/8,192/16,384/32,768/65,536 words. Figure 14 demonstrates Depth Expansion using three IDT7203/7204/7205/7206/7207/7208s. Any depth can be attained by adding additional IDT7203/

7204/7205/7206/7207/7208s. These devices operate in the Depth Expansion mode when the following conditions are met:

1. The first device must be designated by grounding the First Load (\overline{FL}) control input.
2. All other devices must have \overline{FL} in the HIGH state.
3. The Expansion Out (\overline{XO}) pin of each device must be tied to the Expansion In (\overline{XI}) pin of the next device. See Figure 14.
4. External logic is needed to generate a composite Full Flag (\overline{FF}) and Empty Flag (\overline{EF}). This requires the ORing of all \overline{EF} s and ORing of all \overline{FF} s (i.e. all must be set to generate the correct composite \overline{FF} or \overline{EF}). See Figure 14.
5. The Retransmit (\overline{RT}) function and Half-Full Flag (\overline{HF}) are not available in the Depth Expansion Mode.

For additional information on the IDT7203/7204/7205/7206/7207, refer to Tech Note 9: *Cascading FIFOs or FIFO Modules*.

USAGE MODES:

Width Expansion

Word width may be increased simply by connecting the corresponding input control signals of multiple devices. Status flags (\overline{EF} , \overline{FF} and \overline{HF}) can be detected from any one device. Figure 13 demonstrates an 18-bit word width by using two IDT7203/7204/7205/7206/7207/7208s. Any word width can be attained by adding additional IDT7203/7204/7205/7206/7207/7208s (Figure 13).

Bidirectional Operation

Applications which require data buffering between two systems (each system capable of Read and Write operations) can be achieved by pairing IDT7203/7204/7205/7206/7207/7208s as shown in Figure 16. Both Depth Expansion and Width Expansion may be used in this mode.

Data Flow-Through

Two types of flow-through modes are permitted, a read flow-through and write flow-through mode. For the read flow-through mode (Figure 17), the

FIFO permits a reading of a single word after writing one word of data into an empty FIFO. The data is enabled on the bus in ($t_{WEF} + t_A$) ns after the rising edge of \overline{W} , called the first write edge, and it remains on the bus until the \overline{R} line is raised from LOW-to-HIGH, after which the bus would go into a three-state mode after t_{RHZ} ns. The \overline{EF} line would have a pulse showing temporary deassertion and then would be asserted.

In the write flow-through mode (Figure 18), the FIFO permits the writing of a single word of data immediately after reading one word of data from a full FIFO. The \overline{R} line causes the \overline{FF} to be deasserted but the \overline{W} line being LOW causes it to be asserted again in anticipation of a new data word. On the rising edge of \overline{W} , the new word is loaded in the FIFO. The \overline{W} line must be toggled when \overline{FF} is not asserted to write new data in the FIFO and to increment the write pointer.

Compound Expansion

The two expansion techniques described above can be applied together in a straightforward manner to achieve large FIFO arrays (see Figure 15).

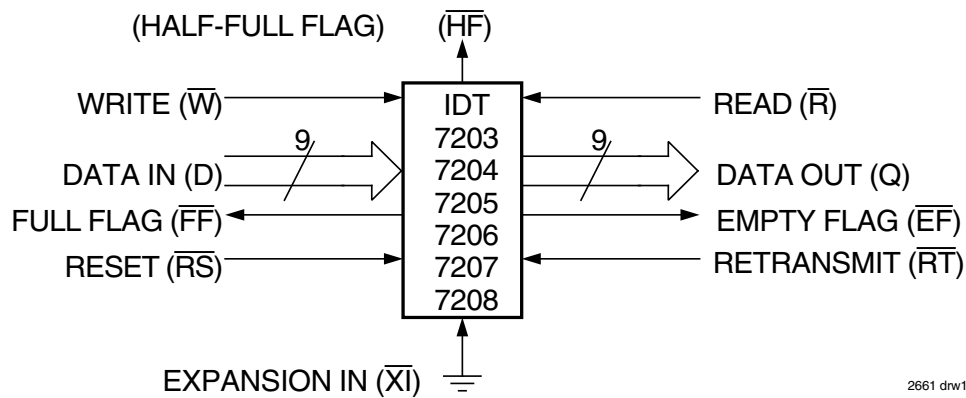

2661 drw14

Figure 12. Block Diagram of 2,048 x 9, 4,096 x 9, 8,192 x 9, 16,384 x 9, 32,768 x 9, 65,536 x 9 FIFO Used in Single Device Mode

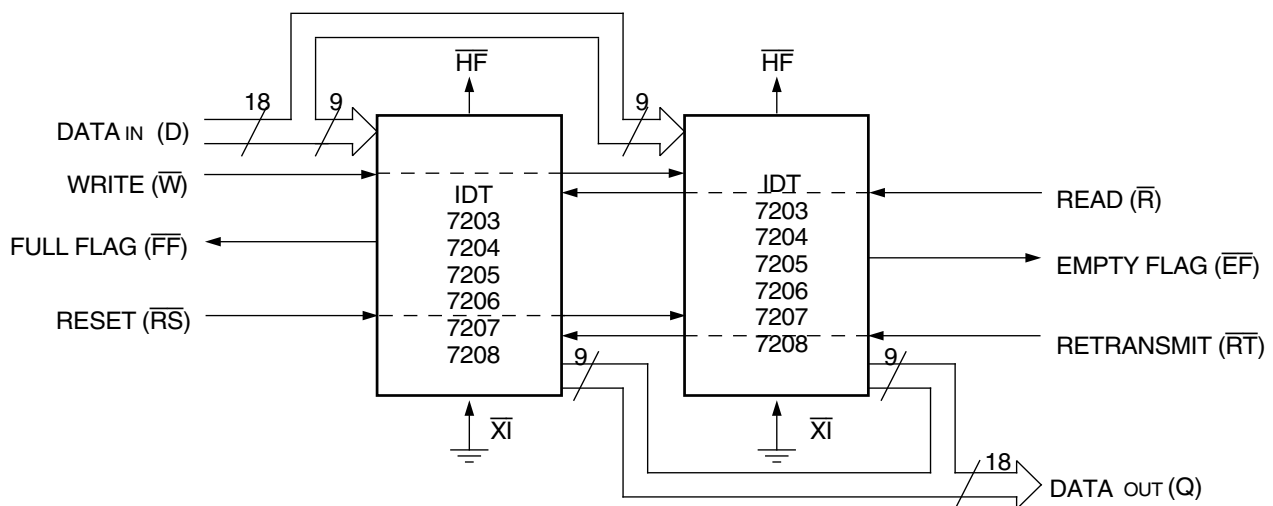

2661 drw15

NOTE:

- Flag detection is accomplished by monitoring the \overline{FF} , \overline{EF} and \overline{HF} signals on either (any) device used in the width expansion configuration. Do not connect any output signals together.

Figure 13. Block Diagram of 2,048 x 18, 4,096 x 18, 8,192 x 18, 16,384 x 18, 32,768 x 18, 65,536 x 18 FIFO Memory Used in Width Expansion Mode

TRUTH TABLES

TABLE 1 – RESET AND RETRANSMIT

SINGLE DEVICE CONFIGURATION/WIDTH EXPANSION MODE

Mode	Inputs			Internal Status		Outputs		
	\overline{RS}	$\overline{FL/RT}$	\overline{XI}	Read Pointer	Write Pointer	\overline{EF}	\overline{FF}	\overline{HF}
Reset	0	X	0	LocationZero	LocationZero	0	1	1
Retransmit	1	0	0	LocationZero	Unchanged	X	X	X
Read/Write	1	1	0	Increment ⁽¹⁾	Increment ⁽¹⁾	X	X	X

NOTE:
 1. Pointer will Increment if flag is HIGH.

TABLE 2 – RESET AND FIRST LOAD

DEPTH EXPANSION/COMPOUND EXPANSION MODE

Mode	Inputs			Internal Status		Outputs	
	\overline{RS}	$\overline{FL/RT}$	\overline{XI}	Read Pointer	Write Pointer	\overline{EF}	\overline{FF}
Reset First Device	0	0	(1)	LocationZero	LocationZero	0	1
Reset All Other Devices	0	1	(1)	LocationZero	LocationZero	0	1
Read/Write	1	X	(1)	X	X	X	X

NOTES:
 1. \overline{XI} is connected to \overline{XO} of previous device. See Figure 14.
 2. \overline{RS} = Reset Input, $\overline{FL/RT}$ = First Load/Retransmit, \overline{EF} = Empty Flag Output, \overline{FF} = Full Flag Output, \overline{XI} = Expansion Input, \overline{HF} = Half-Full Flag Output

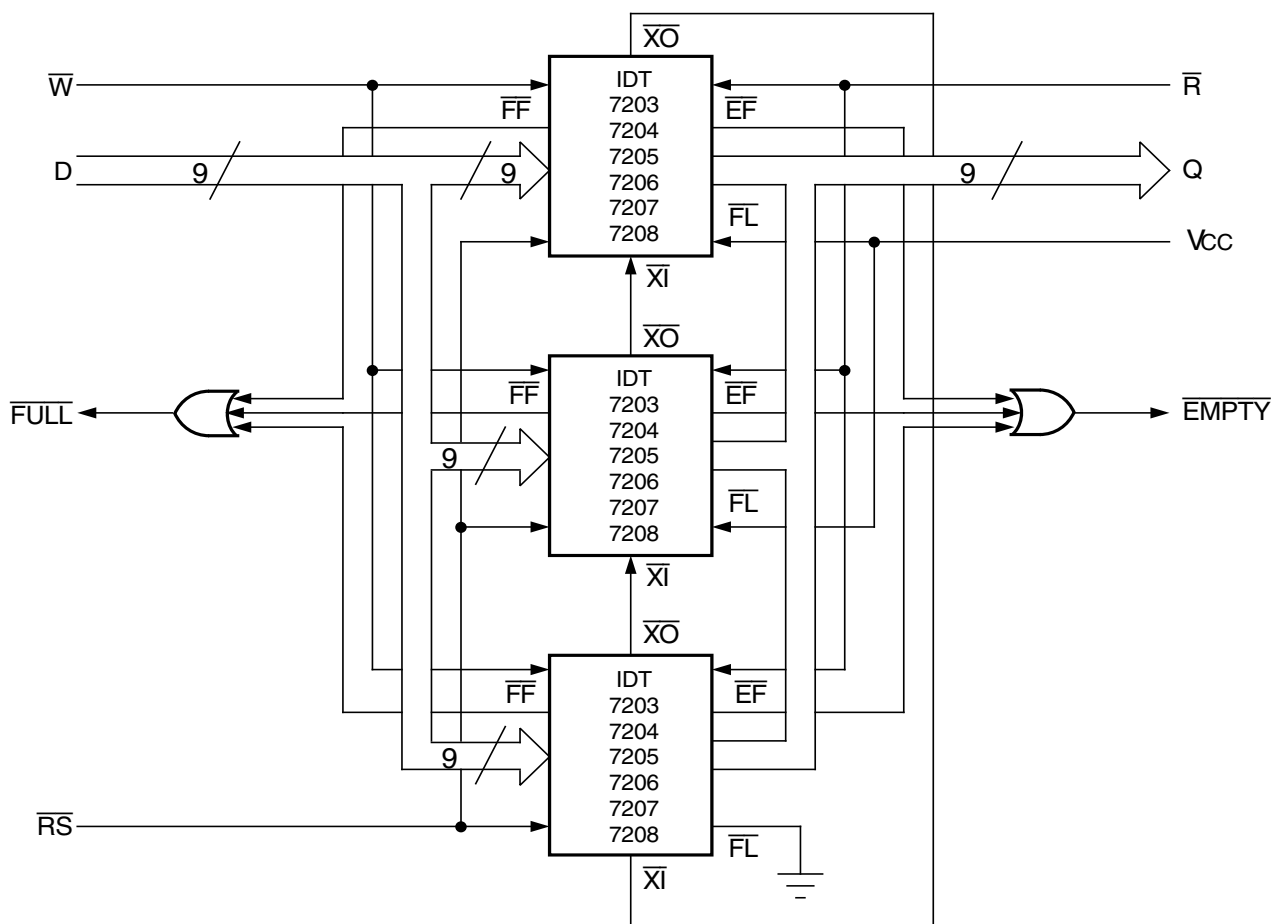

2661 dnr16

Figure 14. Block Diagram of 6,144 x 9, 12,288 x 9, 24,576 x 9, 49,152 x 9, 98,304 x 9, 196,608 x 9 FIFO Memory (Depth Expansion)

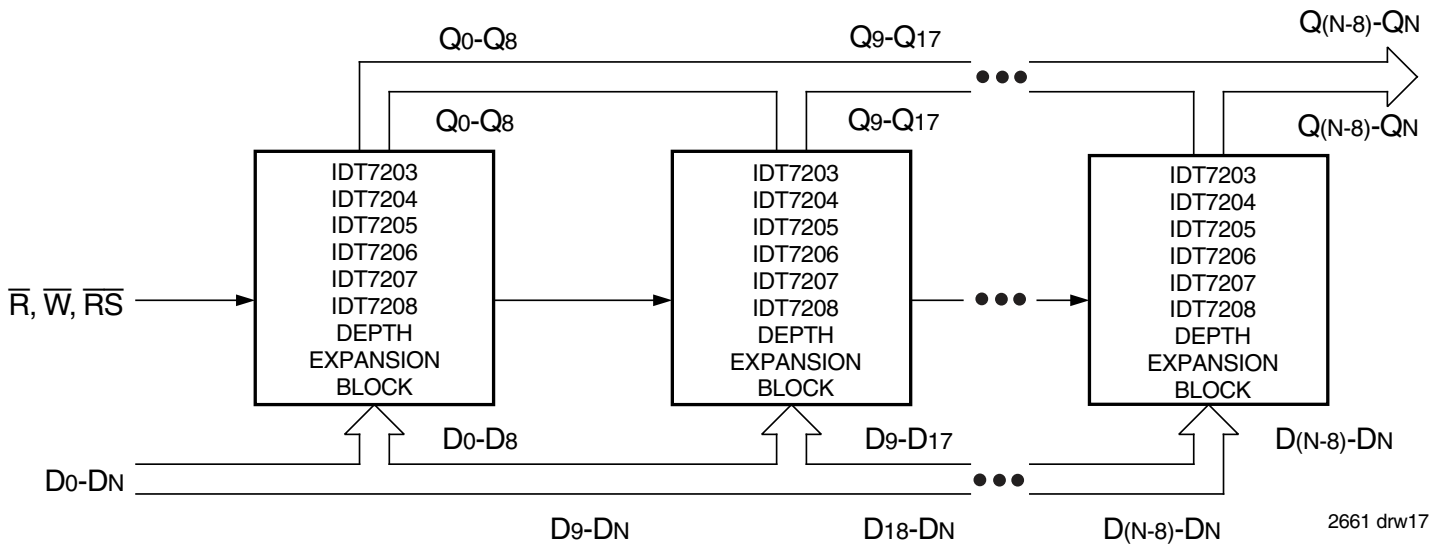

2661 drw17

NOTES:

1. For depth expansion block see section on Depth Expansion and Figure 14.
2. For Flag detection see section on Width Expansion and Figure 13..

Figure 15. Compound FIFO Expansion

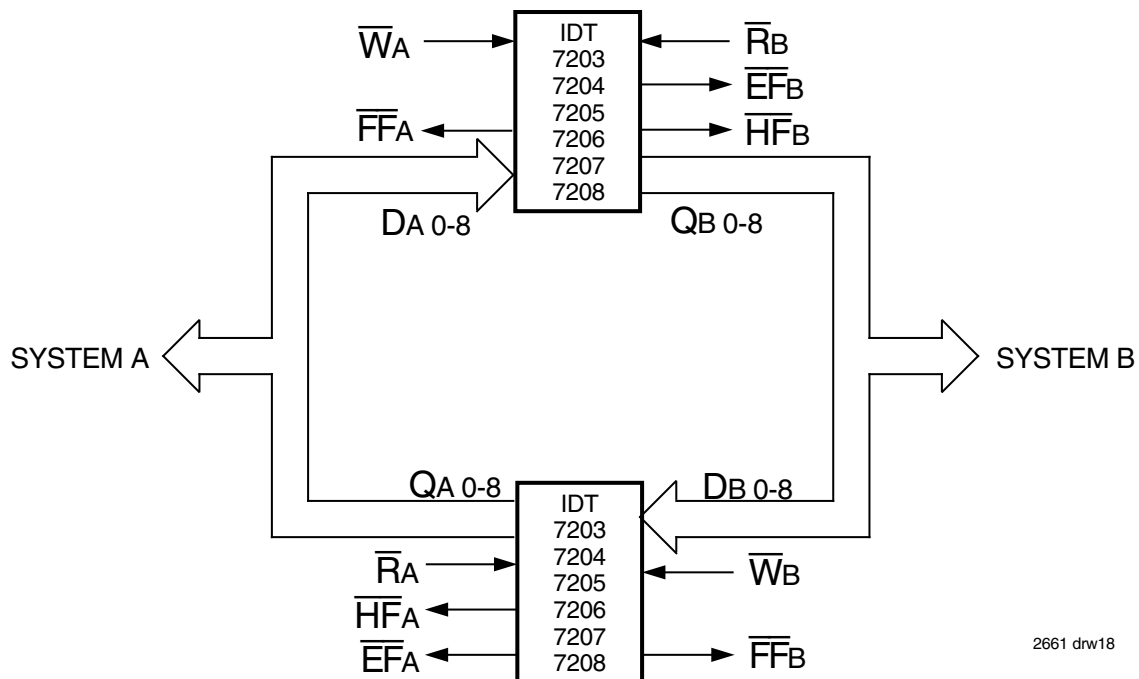

2661 drw18

Figure 16. Bidirectional FIFO Operation

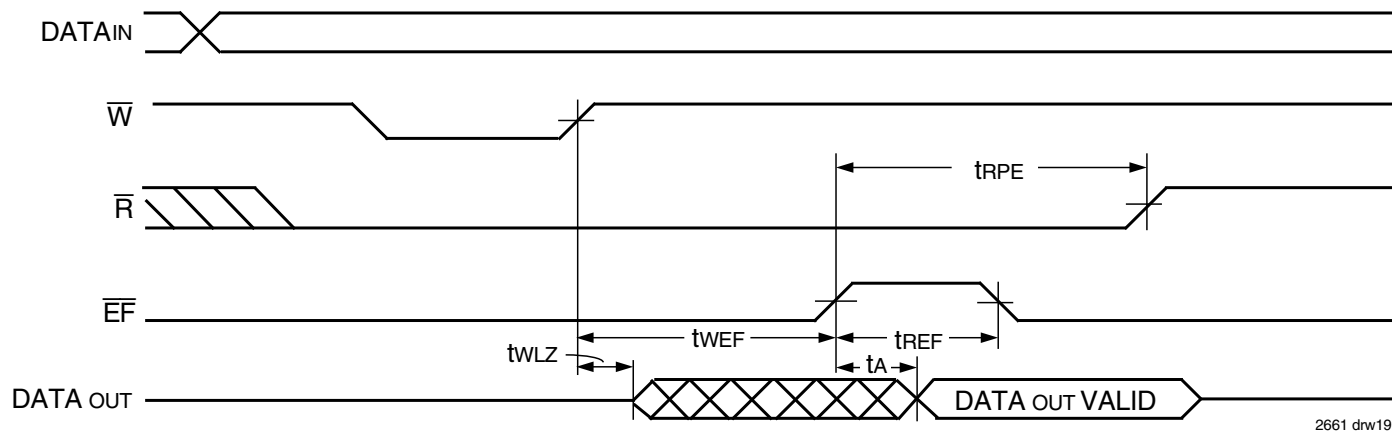

2661 drw19

Figure 17. Read Data Flow-Through Mode

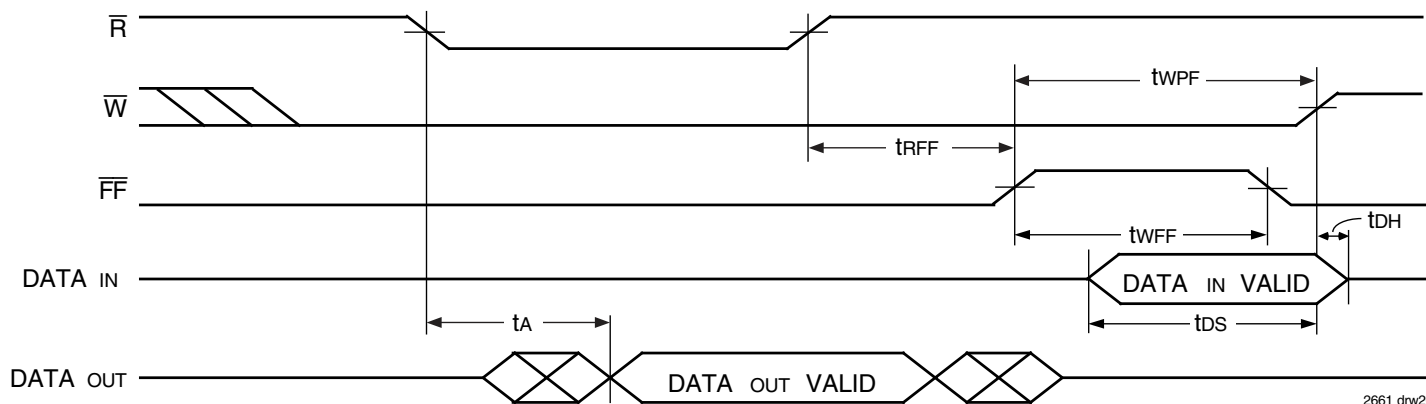

2661 drw20

Figure 18. Write Data Flow-Through Mode

ORDERING INFORMATION

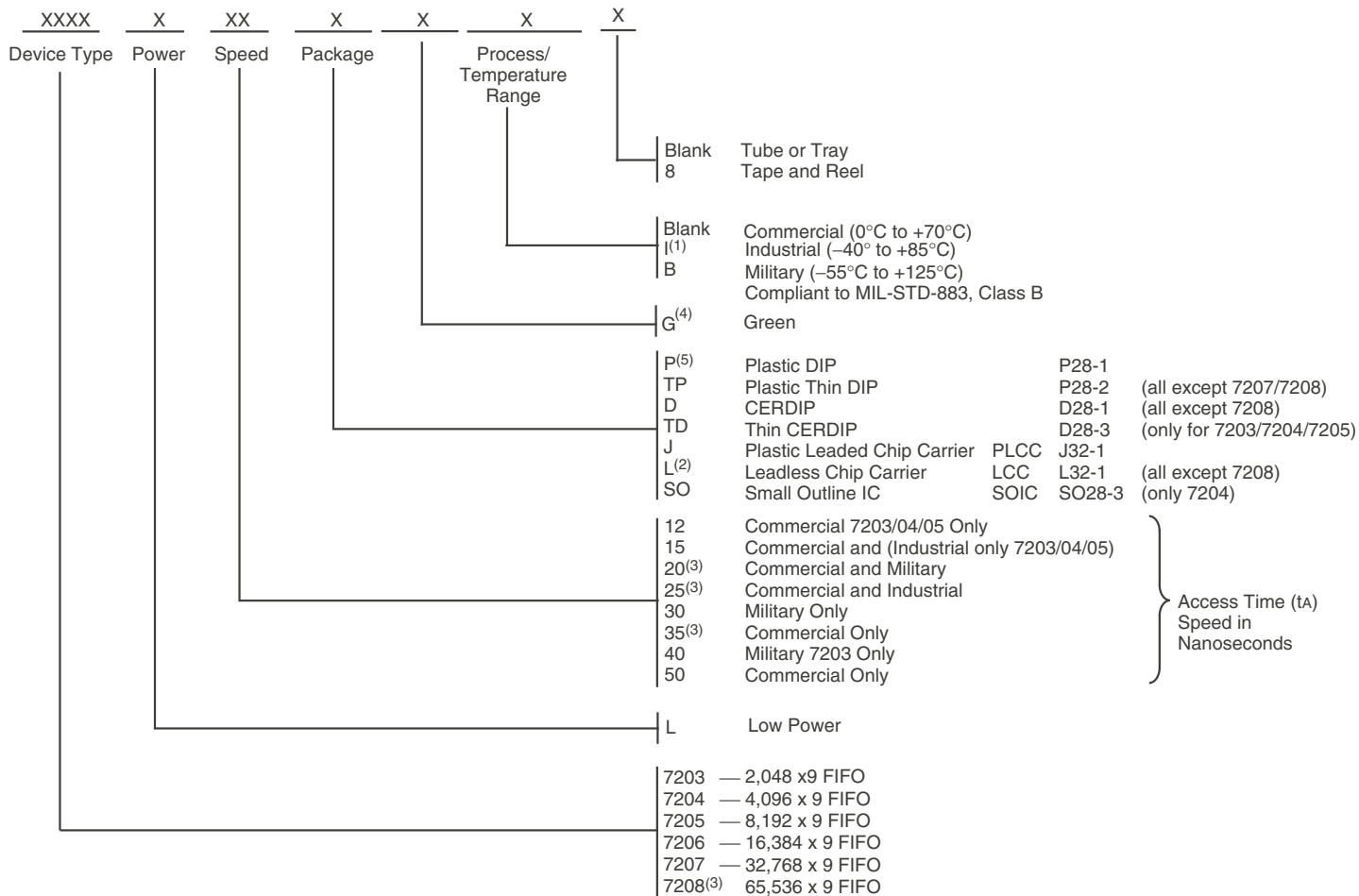

2661 drw21

NOTES:

- Industrial temperature range product for 15ns and 25ns speed grades are available as a standard device for IDT7203/7204/7205, and 25ns speed grade only is available as a standard device for IDT7206/7207/7208. All other speed grades are available by special order.
- The LCC is only available in the military temperature range.
- The IDT7208 is only available in commercial speed grades of 20, 25 and 35 ns.
- Green parts are available. For specific speeds and packages contact your local sales office.
LEAD FINISH (SnPb) parts are in EOL process. Product Discontinuation Notice - PDN# SP-17-02
- For "P", Plastic Dip, when ordering green package, the suffix is "PDG".

IMPORTANT NOTICE AND DISCLAIMER

RENESAS ELECTRONICS CORPORATION AND ITS SUBSIDIARIES (“RENESAS”) PROVIDES TECHNICAL SPECIFICATIONS AND RELIABILITY DATA (INCLUDING DATASHEETS), DESIGN RESOURCES (INCLUDING REFERENCE DESIGNS), APPLICATION OR OTHER DESIGN ADVICE, WEB TOOLS, SAFETY INFORMATION, AND OTHER RESOURCES “AS IS” AND WITH ALL FAULTS, AND DISCLAIMS ALL WARRANTIES, EXPRESS OR IMPLIED, INCLUDING, WITHOUT LIMITATION, ANY IMPLIED WARRANTIES OF MERCHANTABILITY, FITNESS FOR A PARTICULAR PURPOSE, OR NON-INFRINGEMENT OF THIRD PARTY INTELLECTUAL PROPERTY RIGHTS.

These resources are intended for developers skilled in the art designing with Renesas products. You are solely responsible for (1) selecting the appropriate products for your application, (2) designing, validating, and testing your application, and (3) ensuring your application meets applicable standards, and any other safety, security, or other requirements. These resources are subject to change without notice. Renesas grants you permission to use these resources only for development of an application that uses Renesas products. Other reproduction or use of these resources is strictly prohibited. No license is granted to any other Renesas intellectual property or to any third party intellectual property. Renesas disclaims responsibility for, and you will fully indemnify Renesas and its representatives against, any claims, damages, costs, losses, or liabilities arising out of your use of these resources. Renesas' products are provided only subject to Renesas' Terms and Conditions of Sale or other applicable terms agreed to in writing. No use of any Renesas resources expands or otherwise alters any applicable warranties or warranty disclaimers for these products.

(Disclaimer Rev.1.0 Mar 2020)

Corporate Headquarters

TOYOSU FORESIA, 3-2-24 Toyosu,
Koto-ku, Tokyo 135-0061, Japan
www.renesas.com

Contact Information

For further information on a product, technology, the most up-to-date version of a document, or your nearest sales office, please visit:
www.renesas.com/contact/

Trademarks

Renesas and the Renesas logo are trademarks of Renesas Electronics Corporation. All trademarks and registered trademarks are the property of their respective owners.