

## CLC007 Serial Digital Cable Driver with Dual Complementary Outputs

Check for Samples: [CLC007](#)

### FEATURES

- No External Pull-Down Resistors
- Differential Input and Output
- Low Power Dissipation
- Single +5V or –5.2V Supply
- Replaces GS9007 in Most Applications

### APPLICATIONS

- Digital Routers and Distribution Amplifiers
- Coaxial Cable Driver for Digital Transmission Line
- Twisted Pair Driver
- Digital Distribution Amplifiers
- SMPTE, Sonet/SDH, and ATM Compatible Driver
- Buffer Applications

### KEY SPECIFICATION

- 650 ps Rise and Fall Times
- Data Rates to 400 Mbps
- 2 Sets of Complimentary Outputs
- 200 mV Differential Input
- Low Residual Jitter (25 ps<sub>pp</sub>)

### 270 Mbps Eye Pattern

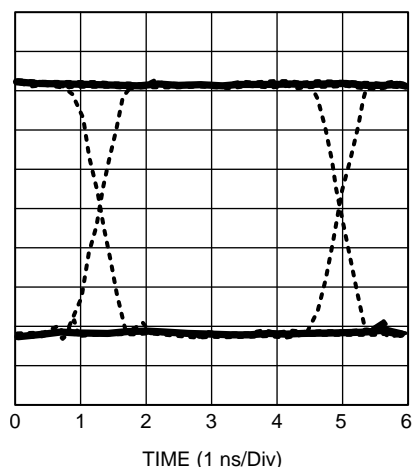
**Figure 1.**

### DESCRIPTION

The Texas Instruments Comlinear CLC007 is a monolithic, high-speed cable driver designed for the SMPTE 259M serial digital video data transmission standard. The CLC007 drives 75Ω transmission lines (Belden 8281 or equivalent) at data rates up to 400 Mbps. Controlled output rise and fall times (750 ps typical) minimize transition-induced jitter. The output voltage swing, typically 1.65V, set by an accurate, low-drift internal bandgap reference, delivers an 800 mV swing to back-matched and terminated 75Ω cable.

The CLC007's class AB output stage consumes less power than other designs, 195 mW with all outputs terminated, and requires no external bias resistors. The differential inputs accept a wide range of digital signals from 200 mV<sub>P-P</sub> to ECL levels within the specified common-mode limits. All this make the CLC007 an excellent general purpose high speed driver for digital applications.

The CLC007 is powered from a single +5V or –5.2V supply and comes in an 8-pin SOIC package.

### Connection Diagram

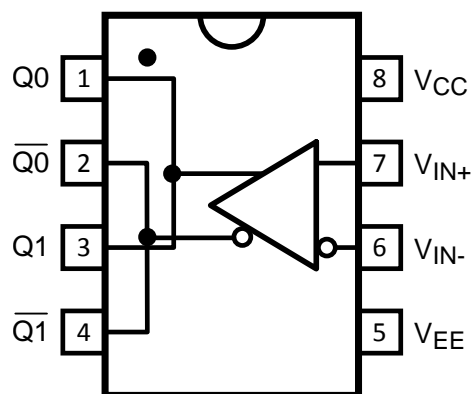
**Figure 2. 8-Pin SOIC  
See D Package**

Please be aware that an important notice concerning availability, standard warranty, and use in critical applications of Texas Instruments semiconductor products and disclaimers thereto appears at the end of this data sheet.

All trademarks are the property of their respective owners.

## Typical Application

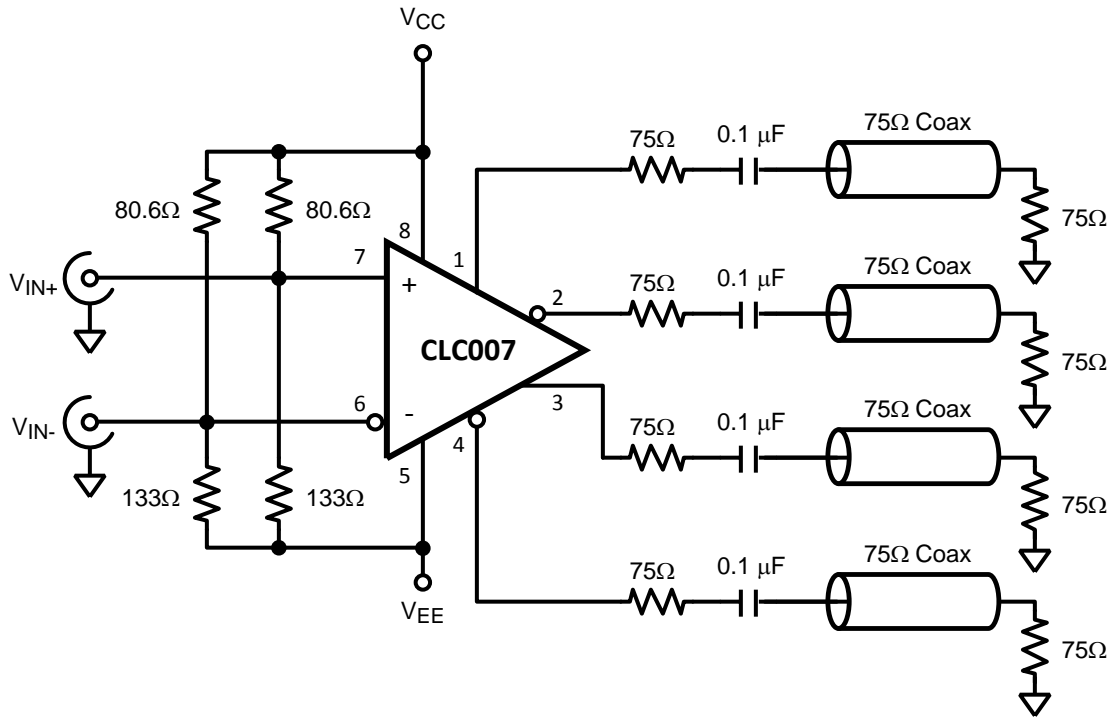

These devices have limited built-in ESD protection. The leads should be shorted together or the device placed in conductive foam during storage or handling to prevent electrostatic damage to the MOS gates.

## ABSOLUTE MAXIMUM RATINGS <sup>(1)(2)</sup>

Supply Voltage		6V
Output Current		30 mA
Maximum Junction Temperature		+125°C
Storage Temperature Range		-65°C to +150°C
Lead Temperature (Soldering 10 Second)		+300°C
ESD Rating (Human body Model)		1000V
Package Thermal Resistance	$\theta_{JA}$ 8-pin SOIC	+160°C
	$\theta_{JC}$ 8-pin SOIC	+105°C/W
Reliability Information	MTTF	254 Mhr

- (1) Absolute Maximum Ratings are those values beyond which the safety of the device cannot be ensured. They are not meant to imply that the devices should be operated at these limits. The table of [ELECTRICAL CHARACTERISTICS](#) specifies conditions of device operation.
- (2) If Military/Aerospace specified devices are required, please contact the Texas Instruments Sales Office/ Distributors for availability and specifications.

## RECOMMENDED OPERATING CONDITIONS

Supply Voltage ( $V_{CC} - V_{EE}$ )	+4.5V to +5.5V
--------------------------------------	----------------

## ELECTRICAL CHARACTERISTICS

( $V_{CC} = 0V$ ,  $V_{EE} = -5V$ ; unless otherwise specified).

Parameter	Conditions	Typ +25°C	Min/Max +25°C	Min/Max 0°C to +70°C	Min/Max -40°C to +85°C	Units
<b>STATIC PERFORMANCE</b>						
Supply Current, Loaded	See <sup>(1)</sup>	39	—	—	—	mA
Supply Current, Unloaded	See <sup>(2)</sup>	34	28/45	26/47	26/47	mA
Output HIGH Voltage ( $V_{OH}$ )	See <sup>(2)</sup>	-1.7	-2.0/1.4	-2.0/1.4	-2.0/1.4	V
Output Low Voltage ( $V_{OL}$ )	See <sup>(2)</sup>	-3.3	-3.6/3.0	-3.6/3.0	-3.6/3.0	V
Input Bias Current		10	30	50	50	μA
Output Swing	See <sup>(2)</sup>	1.65	1.55/1.75	1.53/1.77	1.51/1.79	V
Common Mode Input Range Upper Limit		-0.7	-0.8	-0.8	-0.8	V
Common Mode Input Range Lower Limit		-2.6	-2.5	-2.5	-2.5	V
Minimum Differential Input Swing		200	200	200	200	mV
Power Supply Rejection Ratio <sup>(2)</sup>		26	20	20	20	dB
<b>AC PERFORMANCE</b>						
Output Rise and Fall Time	See <sup>(1)(2)(3)</sup>	650	425/955	400/1100	400/1100	ps
Overshoot		5				%
Propagation Delay		1.0				ns
Duty Cycle Distortion		50				ps
Residual Jitter		25	—	—	—	ps <sub>pp</sub>
<b>MISCELLANEOUS PERFORMANCE</b>						
Input Capacitance		1.0				pF
Output Resistance		10				Ω
Output Inductance		6				nH

(1) Measured with both outputs driving 150Ω, AC coupled at 270 Mbps.

(2) Spec is 100% tested at +25°C

(3) Measured between the 20% and 80% levels of the waveform.

## OPERATION

### Input Interfacing

The CLC007 has high impedance, emitter-follower buffered, differential inputs. Single-ended signals may also be input. Transmission lines supplying input signals must be properly terminated close to the CLC007. Either A.C. or D.C. coupling as in [Figure 4](#) or [Figure 5](#) may be used. [Figure 4](#), [Figure 6](#), and [Figure 7](#) show how Thevenin-equivalent resistor networks are used to provide input termination and biasing. The input D.C. common-mode voltage range is 0.8V to 2.5V below the positive power supply ( $V_{CC}$ ). Input signals plus bias should be kept within the specified common-mode range. For an 800 mV<sub>P-P</sub> input signal, typical input bias levels range from 1.2V to 2.1V below the positive supply.

Load Type	Resistor to $V_{CC}$ (R1)	Resistor to $V_{EE}$ (R2)
ECL, 50Ω, 5V, $V_T=2V$	82.5Ω	124Ω
ECL, 50Ω, 5.2V, $V_T=2V$	80.6Ω	133Ω
ECL, 75Ω, 5V, $V_T=2V$	124Ω	187Ω
ECL, 75Ω, 5.2V, $V_T=2V$	121Ω	196Ω
800 mV <sub>P-P</sub> , 50Ω, 5V, $V_T=1.6V$	75.0Ω	154Ω
800 mV <sub>P-P</sub> , 75Ω, 5V, $V_T=1.6V$	110Ω	232Ω
800 mV <sub>P-P</sub> , 2.2 KΩ, 5V, $V_T=1.6V$	3240Ω	6810Ω

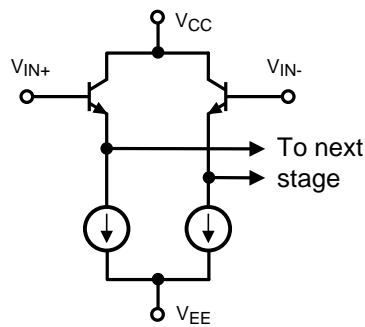

Figure 3. Input Stage

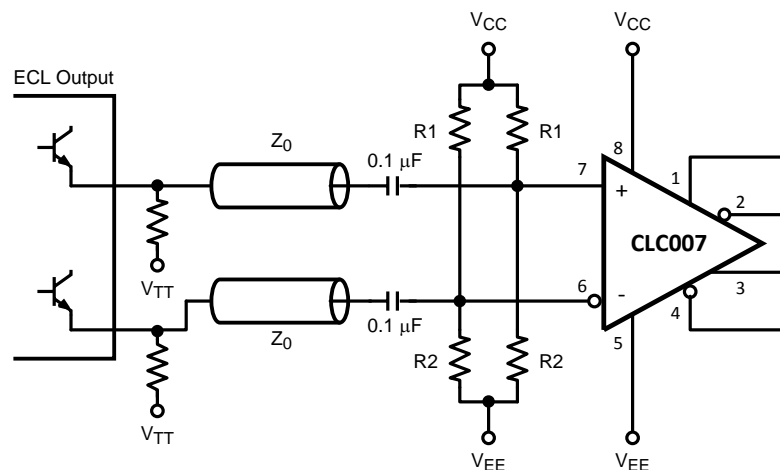

Figure 4. AC Coupled Input

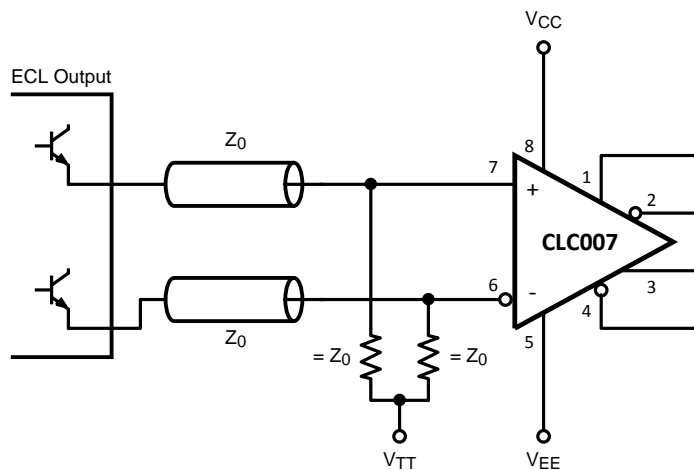

Figure 5. DC Coupled Input

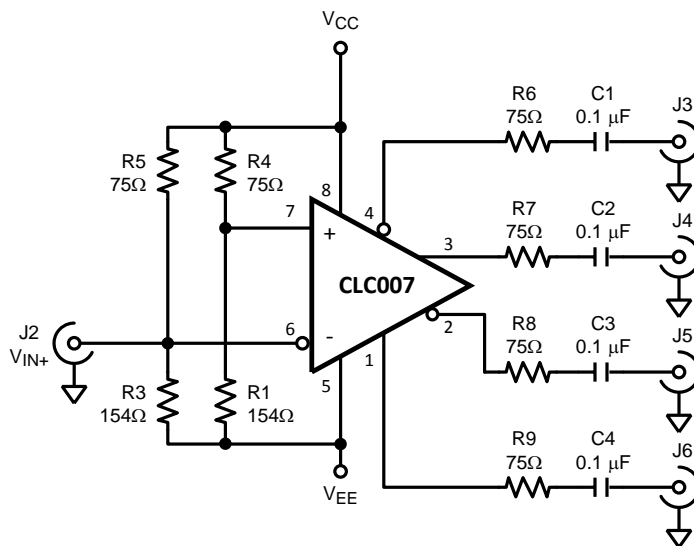
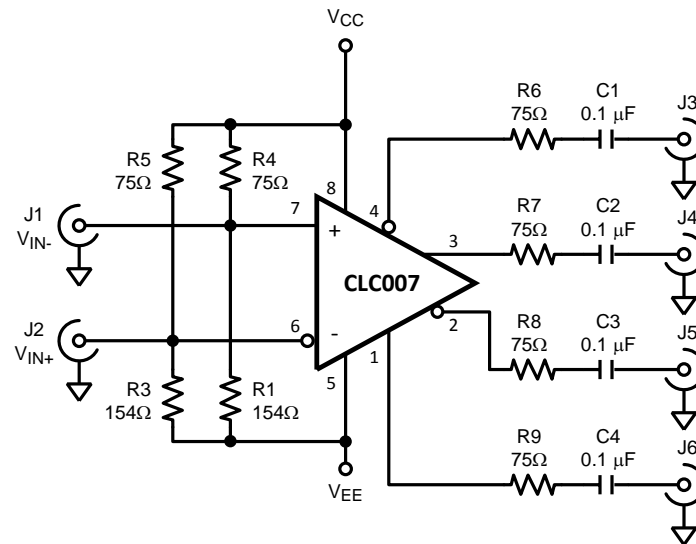

Figure 6. Single Ended 50Ω ECL Input



**Figure 7. Differential 50Ω ECL Input**

### Output Interfacing

The CLC007's class AB output stage, [Figure 8](#), requires no standing current in the output transistors and therefore requires no biasing or pull-down resistors. Advantages of this arrangement are lower power dissipation and fewer external components. The output may be either D.C. or A.C. coupled to the load. A bandgap voltage reference sets output voltage levels which are compatible with F100K and 10K ECL when correctly terminated. The outputs do not have the same output voltage temperature coefficient as 10K. Therefore, noise margins will be reduced over the full temperature range when driving 10K ECL. Noise margins will not be affected when interfacing to F100K since F100K is fully voltage and temperature compensated.

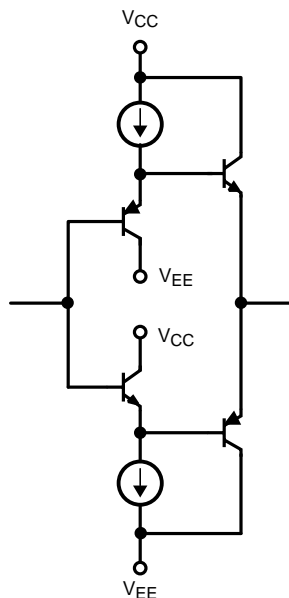

**Figure 8. Output Stage**

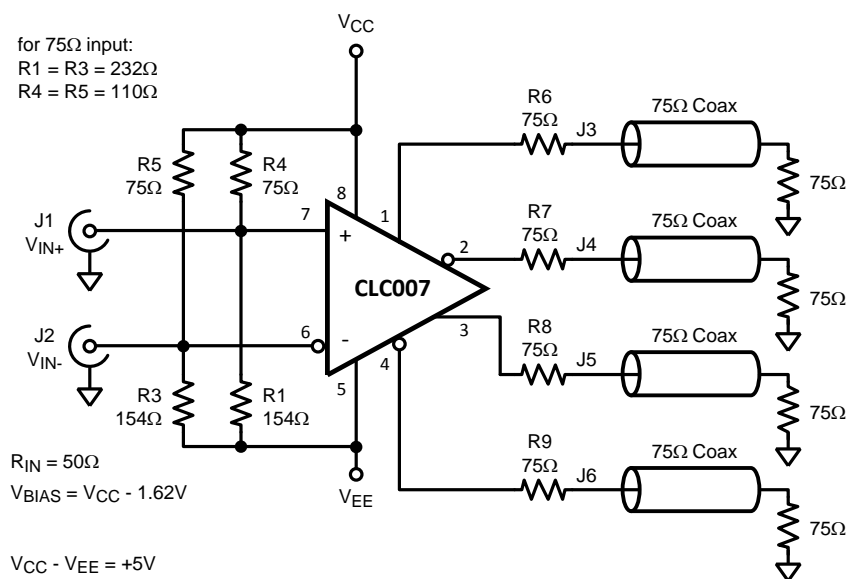
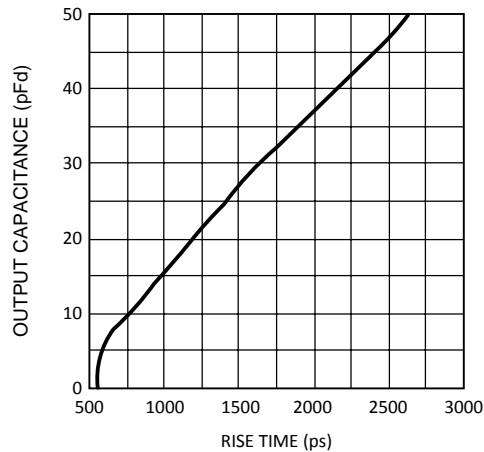

Figure 9. Differential Input DC Coupled Output

## Output Rise And Fall Times

Output load capacitance can significantly affect output rise and fall times. The effect of load capacitance, stray or otherwise, may be reduced by placing the output back-match resistor close to the output pin and by minimizing all interconnecting trace lengths. Figure 10 shows the effect on risetime of parallel load capacitance across a 150Ω load.



**Figure 10. Rise Time vs  $C_L$**

## PCB Layout Recommendations

Printed circuit board layout affects the performance of the CLC007. The following guidelines will aid in achieving satisfactory device performance.

- Use a ground plane or power/ground plane sandwich design for optimum performance.
- Bypass device power with a 0.01  $\mu\text{F}$  monolithic ceramic capacitor in parallel with a 6.8  $\mu\text{F}$  tantalum electrolytic capacitor located no more than 0.1" (2.5 mm) from the device power pins.
- Provide short, symmetrical ground return paths for:
  - Inputs,
  - Supply bypass capacitors and
  - The output load.
- Provide short, grounded guard traces located
  - Under the centerline of the package,
  - 0.1" (2.5 mm) from the package pins
  - On both top and bottom of the board with connecting vias.





---

**REVISION HISTORY**

<b>Changes from Revision D (April 2013) to Revision E</b>	<b>Page</b>
<hr/> <ul style="list-style-type: none"><li>• Changed layout of National Data Sheet to TI format .....</li></ul>	<hr/> <b>8</b>

**PACKAGING INFORMATION**

Orderable Device	Status (1)	Package Type	Package Drawing	Pins	Package Qty	Eco Plan (2)	Lead finish/ Ball material (6)	MSL Peak Temp (3)	Op Temp (°C)	Device Marking (4/5)	Samples
CLC007BM/NOPB	ACTIVE	SOIC	D	8	95	RoHS & Green	SN	Level-1-260C-UNLIM	-40 to 85	CLC00 7BM>D	
CLC007BMX/NOPB	ACTIVE	SOIC	D	8	2500	RoHS & Green	SN	Level-1-260C-UNLIM	-40 to 85	CLC00 7BM>D	

(1) The marketing status values are defined as follows:

**ACTIVE:** Product device recommended for new designs.

**LIFEBUY:** TI has announced that the device will be discontinued, and a lifetime-buy period is in effect.

**NRND:** Not recommended for new designs. Device is in production to support existing customers, but TI does not recommend using this part in a new design.

**PREVIEW:** Device has been announced but is not in production. Samples may or may not be available.

**OBSOLETE:** TI has discontinued the production of the device.

(2) **RoHS:** TI defines "RoHS" to mean semiconductor products that are compliant with the current EU RoHS requirements for all 10 RoHS substances, including the requirement that RoHS substance do not exceed 0.1% by weight in homogeneous materials. Where designed to be soldered at high temperatures, "RoHS" products are suitable for use in specified lead-free processes. TI may reference these types of products as "Pb-Free".

**RoHS Exempt:** TI defines "RoHS Exempt" to mean products that contain lead but are compliant with EU RoHS pursuant to a specific EU RoHS exemption.

**Green:** TI defines "Green" to mean the content of Chlorine (Cl) and Bromine (Br) based flame retardants meet JS709B low halogen requirements of <=1000ppm threshold. Antimony trioxide based flame retardants must also meet the <=1000ppm threshold requirement.

(3) MSL, Peak Temp. - The Moisture Sensitivity Level rating according to the JEDEC industry standard classifications, and peak solder temperature.

(4) There may be additional marking, which relates to the logo, the lot trace code information, or the environmental category on the device.

(5) Multiple Device Markings will be inside parentheses. Only one Device Marking contained in parentheses and separated by a "~" will appear on a device. If a line is indented then it is a continuation of the previous line and the two combined represent the entire Device Marking for that device.

(6) Lead finish/Ball material - Orderable Devices may have multiple material finish options. Finish options are separated by a vertical ruled line. Lead finish/Ball material values may wrap to two lines if the finish value exceeds the maximum column width.

**Important Information and Disclaimer:**The information provided on this page represents TI's knowledge and belief as of the date that it is provided. TI bases its knowledge and belief on information provided by third parties, and makes no representation or warranty as to the accuracy of such information. Efforts are underway to better integrate information from third parties. TI has taken and continues to take reasonable steps to provide representative and accurate information but may not have conducted destructive testing or chemical analysis on incoming materials and chemicals. TI and TI suppliers consider certain information to be proprietary, and thus CAS numbers and other limited information may not be available for release.

In no event shall TI's liability arising out of such information exceed the total purchase price of the TI part(s) at issue in this document sold by TI to Customer on an annual basis.



**TAPE AND REEL INFORMATION**

**QUADRANT ASSIGNMENTS FOR PIN 1 ORIENTATION IN TAPE**



\*All dimensions are nominal

Device	Package Type	Package Drawing	Pins	SPQ	Reel Diameter (mm)	Reel Width W1 (mm)	A0 (mm)	B0 (mm)	K0 (mm)	P1 (mm)	W (mm)	Pin1 Quadrant
CLC007BMX/NOPB	SOIC	D	8	2500	330.0	12.4	6.5	5.4	2.0	8.0	12.0	Q1

**TAPE AND REEL BOX DIMENSIONS**

\*All dimensions are nominal

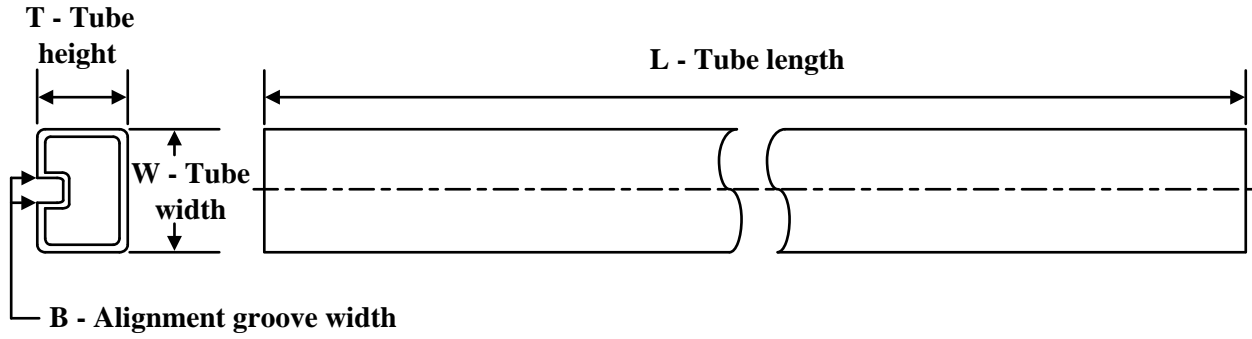
Device	Package Type	Package Drawing	Pins	SPQ	Length (mm)	Width (mm)	Height (mm)
CLC007BMX/NOPB	SOIC	D	8	2500	367.0	367.0	35.0

**TUBE**

\*All dimensions are nominal

Device	Package Name	Package Type	Pins	SPQ	L (mm)	W (mm)	T (μm)	B (mm)
CLC007BM/NOPB	D	SOIC	8	95	495	8	4064	3.05



D0008A

# PACKAGE OUTLINE

SOIC - 1.75 mm max height

SMALL OUTLINE INTEGRATED CIRCUIT

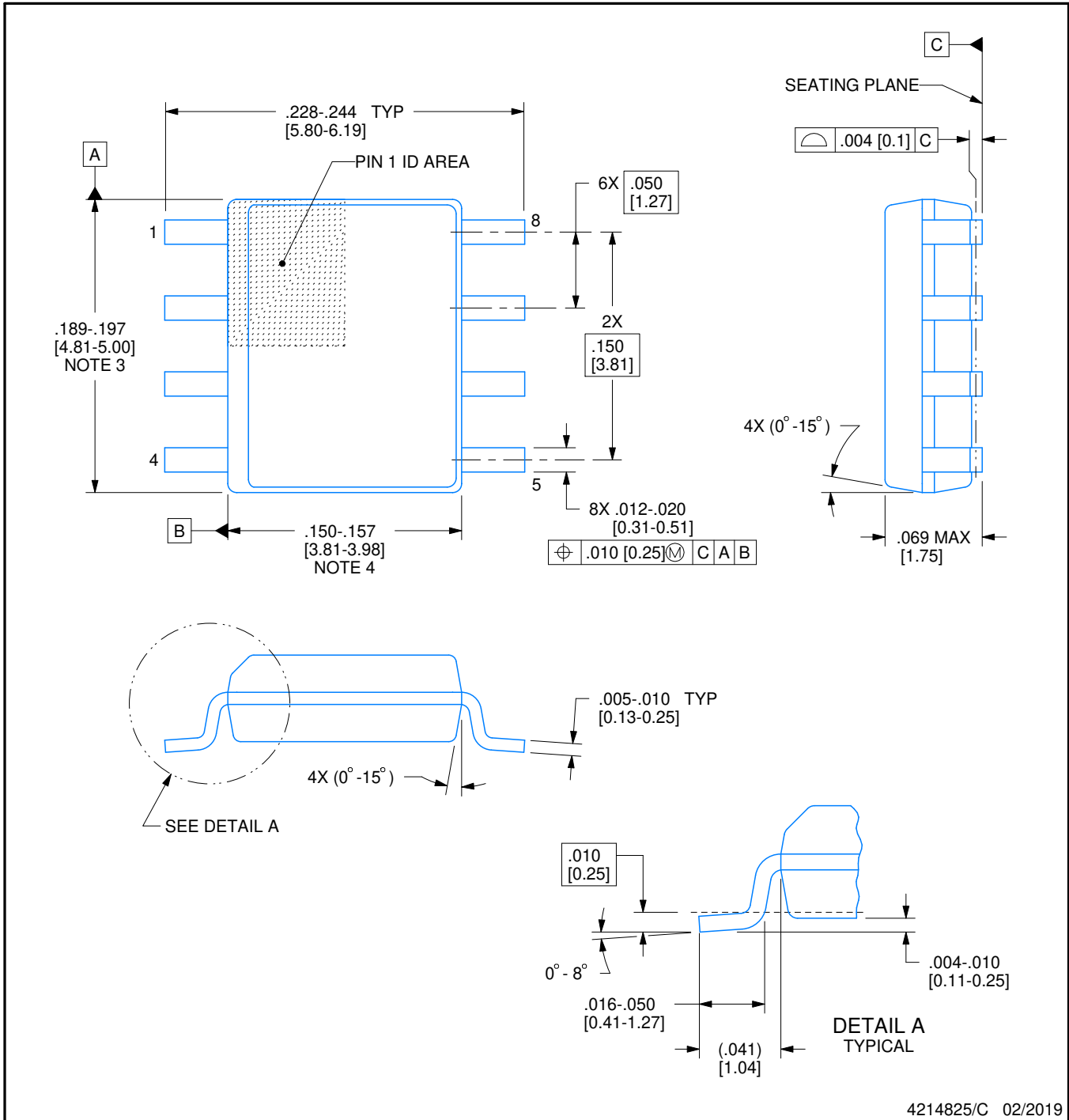

4214825/C 02/2019

NOTES:

- Linear dimensions are in inches [millimeters]. Dimensions in parenthesis are for reference only. Controlling dimensions are in inches. Dimensioning and tolerancing per ASME Y14.5M.
- This drawing is subject to change without notice.
- This dimension does not include mold flash, protrusions, or gate burrs. Mold flash, protrusions, or gate burrs shall not exceed .006 [0.15] per side.
- This dimension does not include interlead flash.
- Reference JEDEC registration MS-012, variation AA.

# EXAMPLE BOARD LAYOUT

D0008A

SOIC - 1.75 mm max height

SMALL OUTLINE INTEGRATED CIRCUIT



LAND PATTERN EXAMPLE  
EXPOSED METAL SHOWN  
SCALE:8X



SOLDER MASK DETAILS

4214825/C 02/2019

NOTES: (continued)

- 6. Publication IPC-7351 may have alternate designs.
- 7. Solder mask tolerances between and around signal pads can vary based on board fabrication site.



# EXAMPLE STENCIL DESIGN

D0008A

SOIC - 1.75 mm max height

SMALL OUTLINE INTEGRATED CIRCUIT



SOLDER PASTE EXAMPLE  
BASED ON .005 INCH [0.125 MM] THICK STENCIL  
SCALE:8X

4214825/C 02/2019

NOTES: (continued)

8. Laser cutting apertures with trapezoidal walls and rounded corners may offer better paste release. IPC-7525 may have alternate design recommendations.
9. Board assembly site may have different recommendations for stencil design.

## IMPORTANT NOTICE AND DISCLAIMER

TI PROVIDES TECHNICAL AND RELIABILITY DATA (INCLUDING DATA SHEETS), DESIGN RESOURCES (INCLUDING REFERENCE DESIGNS), APPLICATION OR OTHER DESIGN ADVICE, WEB TOOLS, SAFETY INFORMATION, AND OTHER RESOURCES "AS IS" AND WITH ALL FAULTS, AND DISCLAIMS ALL WARRANTIES, EXPRESS AND IMPLIED, INCLUDING WITHOUT LIMITATION ANY IMPLIED WARRANTIES OF MERCHANTABILITY, FITNESS FOR A PARTICULAR PURPOSE OR NON-INFRINGEMENT OF THIRD PARTY INTELLECTUAL PROPERTY RIGHTS.

These resources are intended for skilled developers designing with TI products. You are solely responsible for (1) selecting the appropriate TI products for your application, (2) designing, validating and testing your application, and (3) ensuring your application meets applicable standards, and any other safety, security, regulatory or other requirements.

These resources are subject to change without notice. TI grants you permission to use these resources only for development of an application that uses the TI products described in the resource. Other reproduction and display of these resources is prohibited. No license is granted to any other TI intellectual property right or to any third party intellectual property right. TI disclaims responsibility for, and you will fully indemnify TI and its representatives against, any claims, damages, costs, losses, and liabilities arising out of your use of these resources.

TI's products are provided subject to [TI's Terms of Sale](#) or other applicable terms available either on [ti.com](http://ti.com) or provided in conjunction with such TI products. TI's provision of these resources does not expand or otherwise alter TI's applicable warranties or warranty disclaimers for TI products.

TI objects to and rejects any additional or different terms you may have proposed.

Mailing Address: Texas Instruments, Post Office Box 655303, Dallas, Texas 75265  
Copyright © 2022, Texas Instruments Incorporated