

PRODUCT NO.

JSC 96358

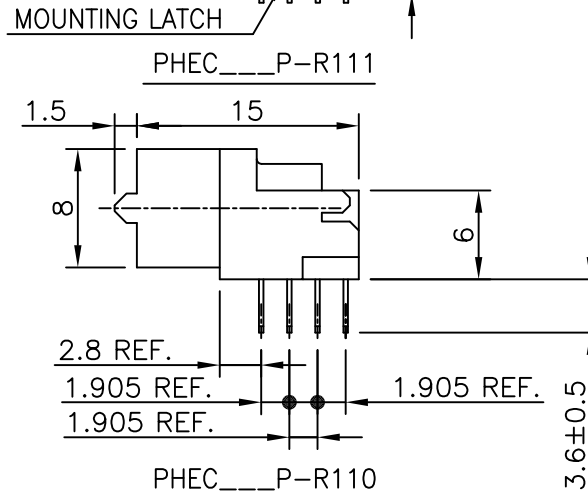

RECOMMENDED PC BOARD  
THICKNESS : 1.6 ±0.2  
HOLE PATTERN (COMPONENT SIDE)

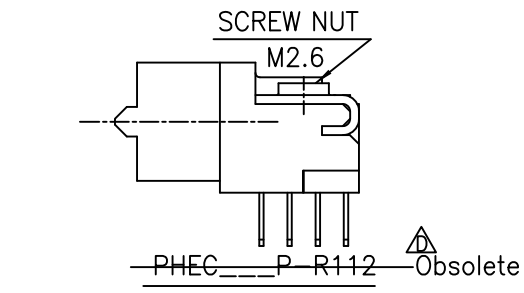
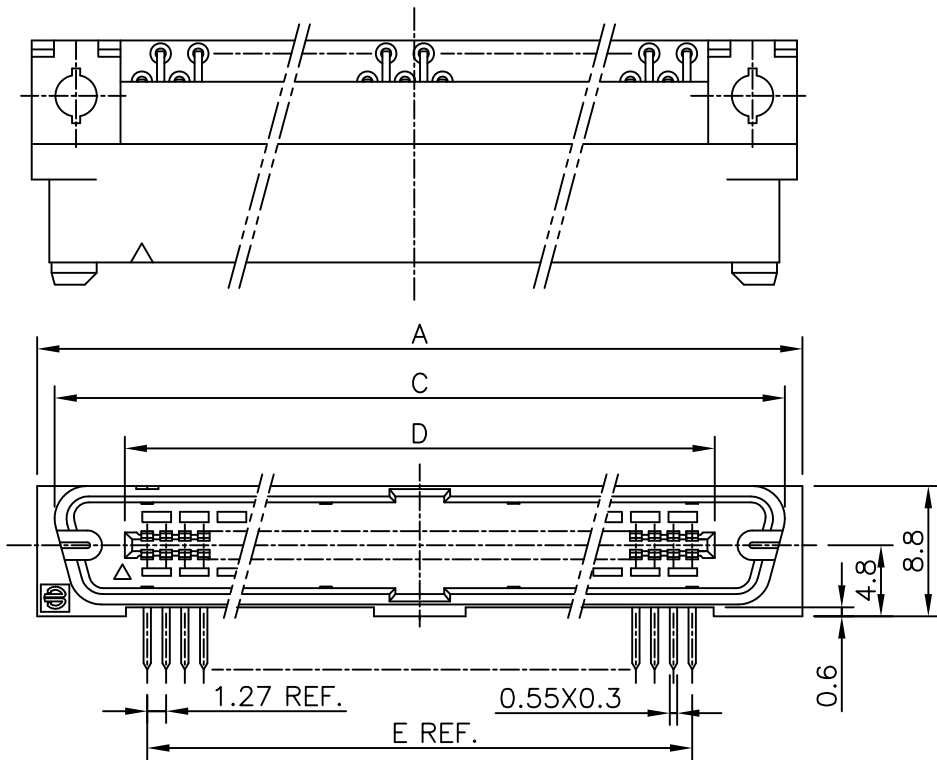
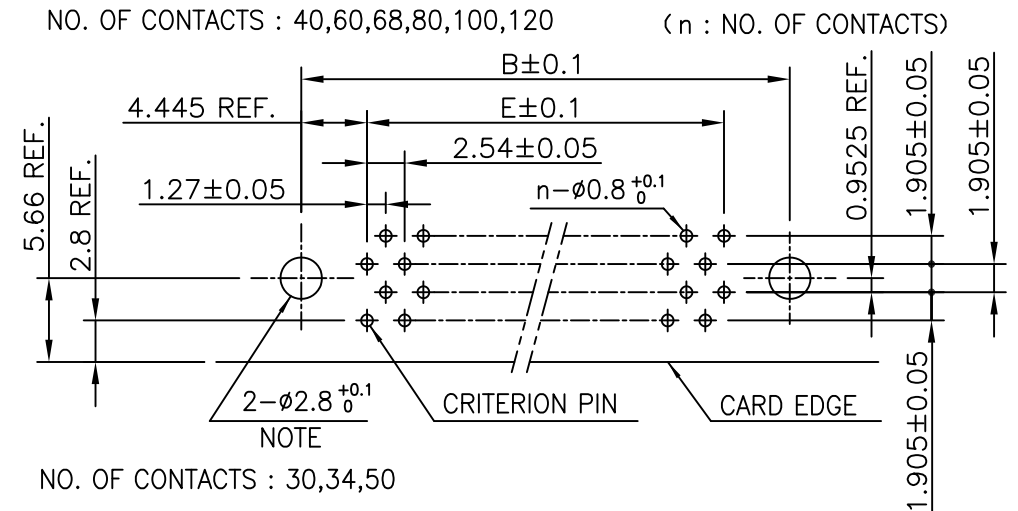

NO. OF CONTACTS : 30,34,50

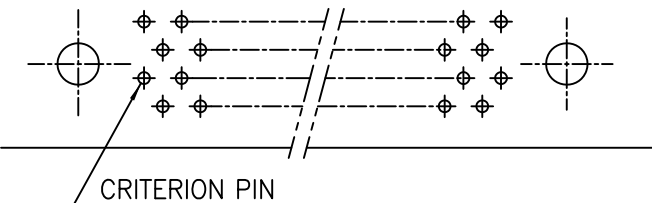

NOTE : THROUGH-HOLES FOR MOUNTING LATCHES ALSO SHOULD BE PLATED.

NO. OF CONTACTS : 40,60,68,80,100,120

CRITERION PIN

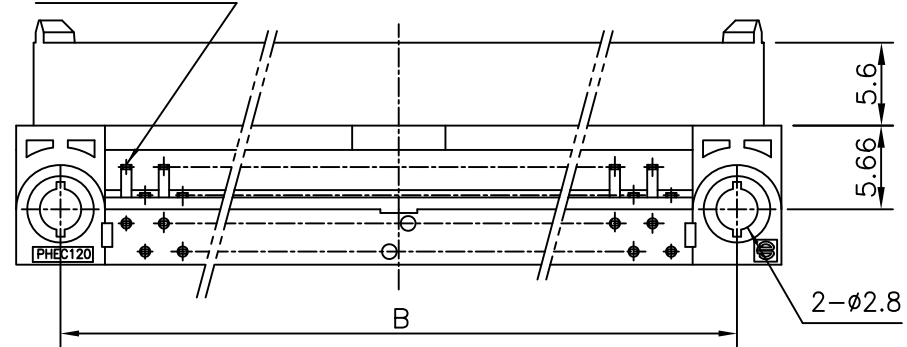

NO. OF CONTACTS : 30,34,50

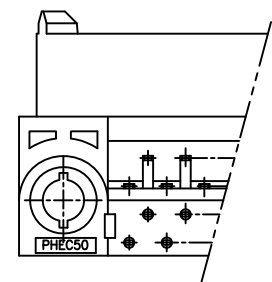

CAT. NO.	NO. OF CONTACTS (MATING SIDE)	DIMENSIONS				
		A	B	C	D	E
PHEC30P-R11_LF	15/ROW X 2 ROWS	32.67	26.67	30.30	20.42	17.78
PHEC34P-R11_LF	17/ROW X 2 ROWS	35.21	29.21	32.84	22.96	20.32
PHEC40P-R11_LF	20/ROW X 2 ROWS	39.02	33.02	36.65	26.77	24.13
PHEC50P-R11_LF	25/ROW X 2 ROWS	45.37	39.37	43.00	33.12	30.48
PHEC60P-R11_LF	30/ROW X 2 ROWS	51.72	45.72	49.35	39.47	36.83
PHEC68P-R11_LF	34/ROW X 2 ROWS	56.80	50.80	54.43	44.55	41.91
PHEC80P-R11_LF	40/ROW X 2 ROWS	64.42	58.42	62.05	52.17	49.53
PHEC100P-R11_LF	50/ROW X 2 ROWS	77.12	71.12	74.75	64.87	62.23
PHEC120P-R11_LF	60/ROW X 2 ROWS	89.82	83.82	87.45	77.57	74.93

NOTES

- BODY MATERIAL : NYLON GLASS FILLED (UL94V-0), COLOR BLACK
- TERMINAL MATERIAL : PHOSPHOR BRONZE
- MOUNTING LATCH MATERIAL : PHOSPHOR BRONZE
- LOCATOR MATERIAL : PBT GLASS FILLED
- SCREW NUT : STEEL
- TERMINAL FINISH  
CONTACT AREA : GOLD FLASH 0.1μm min. OVER NICKEL UNDERLAYER  
SOLDER TAILS : PURE Sn 2μm min. OVER NICKEL UNDERLAYER
- MOUNTING LATCH FINISH : PURE Sn 2μm min. OVER NICKEL UNDERLAYER
- SCREW FINISH : NICKEL
- THIS PRODUCT MEETS EUROPEAN UNION DIRECTIVES AND OTHER COUNTRY REGULATIONS AS DESCRIBED IN GS-22-008
- THE HOUSING WILL WITHSTAND EXPOSURE TO 260 DEGREE PEAK TEMPERATURE FOR 10 SECONDS IN A WAVE SOLDER APPLICATION WITH A 1.6mm MINIMUM THICK CIRCUIT BOARD.

mat'l. code		surface ISO 1302		tolerance ISO 406 ISO 1101		projection		product family PHEC		CODE JP	
ltr		description		ecn no		dr		date		title	
A		RELEASED		J05-0186		S.O		3/29/'05		PRINTED CIRCUIT CONNECTOR (CAT.NO.PHEC ___ P-R11_LF)	
B		REVISED		J07-0047		S.O		1/25/'07		MM	
C		REVISED		J07-0458		S.O		9/11/'07		scale N/A	
D		EOL of R112LF		ELX-J-17067		S.W		2/27/'14		dwg no sheet 1 of 1 size	
						dr		S.Watanabe 2/27/'14		JSC 96358 A3	
						enr		S.Watanabe 2/27/'14		type Customer Drawing	
						chr		K.Ito 2/27/'14			
						appd		Y.Kameda 2/27/'14			
sheet index		revision sheet		D 1						Rev. D	