



RF360
Europe GmbH

SAW components

SAW duplexer

Small cell & femtocell
LTE band 13

Series/type:	B8005
Ordering code:	B39781B8005P810
Date:	January 23, 2018
Version:	2.2

RF360 products mentioned within this document are products of RF360 Europe GmbH and other subsidiaries of RF360 Holdings Singapore Pte. Ltd. (collectively, the "RF360 Subsidiaries").

RF360 Europe GmbH, Anzinger Str. 13, München, Germany

© 2019 RF360 Europe GmbH and/or its affiliated companies. All rights reserved.



RF360
Europe GmbH

These materials, including the information contained herein, may be used only for informational purposes by the customer. The RF360 Subsidiaries assume no responsibility for errors or omissions in these materials or the information contained herein. The RF360 Subsidiaries reserve the right to make changes to the product(s) or information contained herein without notice. The materials and information are provided on an AS IS basis, and the RF360 Subsidiaries assume no liability and make no warranty or representation, either expressed or implied, with respect to the materials, or any output or results based on the use, application, or evaluation of such materials, including, without limitation, with respect to the non-infringement of trademarks, patents, copyrights or any other intellectual property rights or other rights of third parties.

No use of this documentation or any information contained herein grants any license, whether express, implied, by estoppel or otherwise, to any intellectual property rights, including, without limitation, to any patents owned by QUALCOMM Incorporated or any of its subsidiaries.

Not to be used, copied, reproduced, or modified in whole or in part, nor its contents revealed in any manner to others without the express written permission of RF360 Europe GmbH.

Qualcomm is a trademark of Qualcomm Incorporated, registered in the United States and other countries. Other product and brand names may be trademarks or registered trademarks of their respective owners.

This technical data may be subject to U.S. and international export, re-export, or transfer ("export") laws. Diversion contrary to U.S. and international law is strictly prohibited.

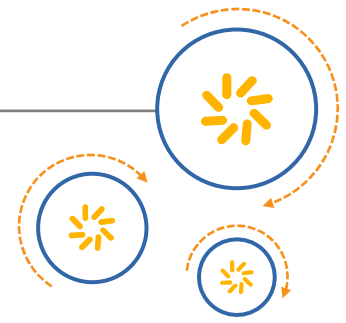

RF360 Europe GmbH
A Qualcomm – TDK Joint Venture

SAW components

SAW duplexer

Small cell & femtocell
LTE band 13

Series/type:	B8005
Ordering code:	B39781B8005P810
Date:	January 23, 2018
Version:	2.2

RF360 products mentioned within this document are offered by RF360 Europe GmbH and other subsidiaries of RF360 Holdings Singapore Pte. Ltd. (collectively, the “RF360 Subsidiaries”).

RF360 Holdings Singapore Pte. Ltd. is a joint venture of Qualcomm Global Trading Pte. Ltd. and EPCOS AG.

RF360 Europe GmbH, Anzinger Str. 13, München, Germany

© 2018 RF360 Europe GmbH and/or its affiliated companies. All rights reserved.

These materials, including the information contained herein, may be used only for informational purposes by the customer. The RF360 Subsidiaries assume no responsibility for errors or omissions in these materials or the information contained herein. The RF360 Subsidiaries reserve the right to make changes to the product(s) or information contained herein without notice. The materials and information are provided on an AS IS basis, and the RF360 Subsidiaries assume no liability and make no warranty or representation, either expressed or implied, with respect to the materials, or any output or results based on the use, application, or evaluation of such materials, including, without limitation, with respect to the non-infringement of trademarks, patents, copyrights or any other intellectual property rights or other rights of third parties.

No use of this documentation or any information contained herein grants any license, whether express, implied, by estoppel or otherwise, to any intellectual property rights, including, without limitation, to any patents owned by QUALCOMM Incorporated or any of its subsidiaries.

Not to be used, copied, reproduced, or modified in whole or in part, nor its contents revealed in any manner to others without the express written permission of RF360 Europe GmbH.

Qualcomm and Qualcomm RF360 are trademarks of Qualcomm Incorporated, registered in the United States and other countries. RF360 is a trademark of Qualcomm Incorporated. Other product and brand names may be trademarks or registered trademarks of their respective owners.

This technical data may be subject to U.S. and international export, re-export, or transfer (“export”) laws. Diversion contrary to U.S. and international law is strictly prohibited.

SAW components	B8005
SAW duplexer	751 / 782 MHz

Data sheet

Table of contents

1 Application	4
2 Features	4
3 Package	5
4 Pin configuration	5
5 Matching circuit	6
6 Characteristics	7
7 Maximum ratings	10
8 Transmission coefficients	11
9 Reflection coefficients	14
10 EVMS	15
11 Packing material	17
12 Marking	21
13 Soldering profile	22
14 Annotations	23
15 Cautions and warnings	24
Important notes	25

SAW components

B8005

SAW duplexer

751 / 782 MHz

Data sheet

1 Application

- Low-loss SAW duplexer for LTE small cell & femtocell systems (Band 13)
- Usable pass band 10 MHz
- Low insertion attenuation
- Low insertion ripple
- High power durability
- Rx = uplink = 777 – 787 MHz
- Tx = downlink = 746 – 756 MHz

2 Features

- Industrial grade qualified family
- Package size 2.5±0.1 mm × 2.0±0.1 mm
- Package height 0.5 mm (max.)
- Approximate weight 0.01 g
- RoHS compatible
- Package for Surface Mount Technology (SMT)
- Ni/Au-plated terminals
- Electrostatic Sensitive Device (ESD)
- Moisture Sensitivity Level 2a (MSL2a)



Figure 1: Picture of component with example of product marking.

SAW components **B8005**

SAW duplexer **751 / 782 MHz**

Data sheet

3 Package

BOTTOM VIEW

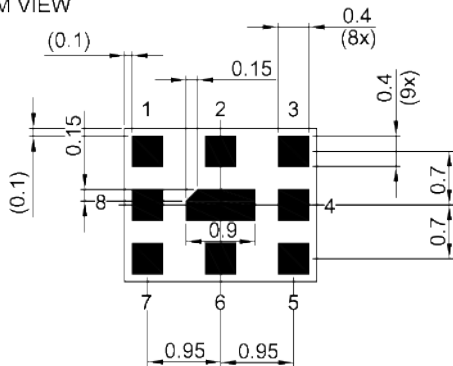

Pad and pitch tolerance ±0.05

SIDE VIEW

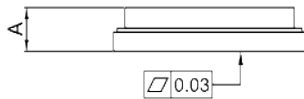

TOP VIEW

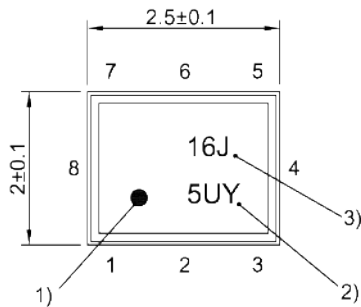

- 1) Marking for pad number 1
- 2) Example of encoded lot number
- 3) Example of encoded filter type number

Land pattern THRU VIEW

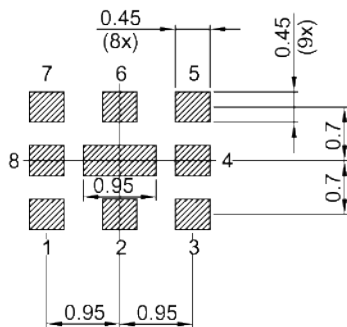

Landing pad tolerance -0.02

Figure 2: Drawing of package with package height A = 0.5 mm (max.). See Sec. Package information (p. 24).

4 Pin configuration

- 1 TX
- 3 RX
- 6 ANT
- 2, 4, 5, 7, 8, 9 Ground

Data sheet

5 Matching circuit

- $L_{p6} = 17 \text{ nH}$

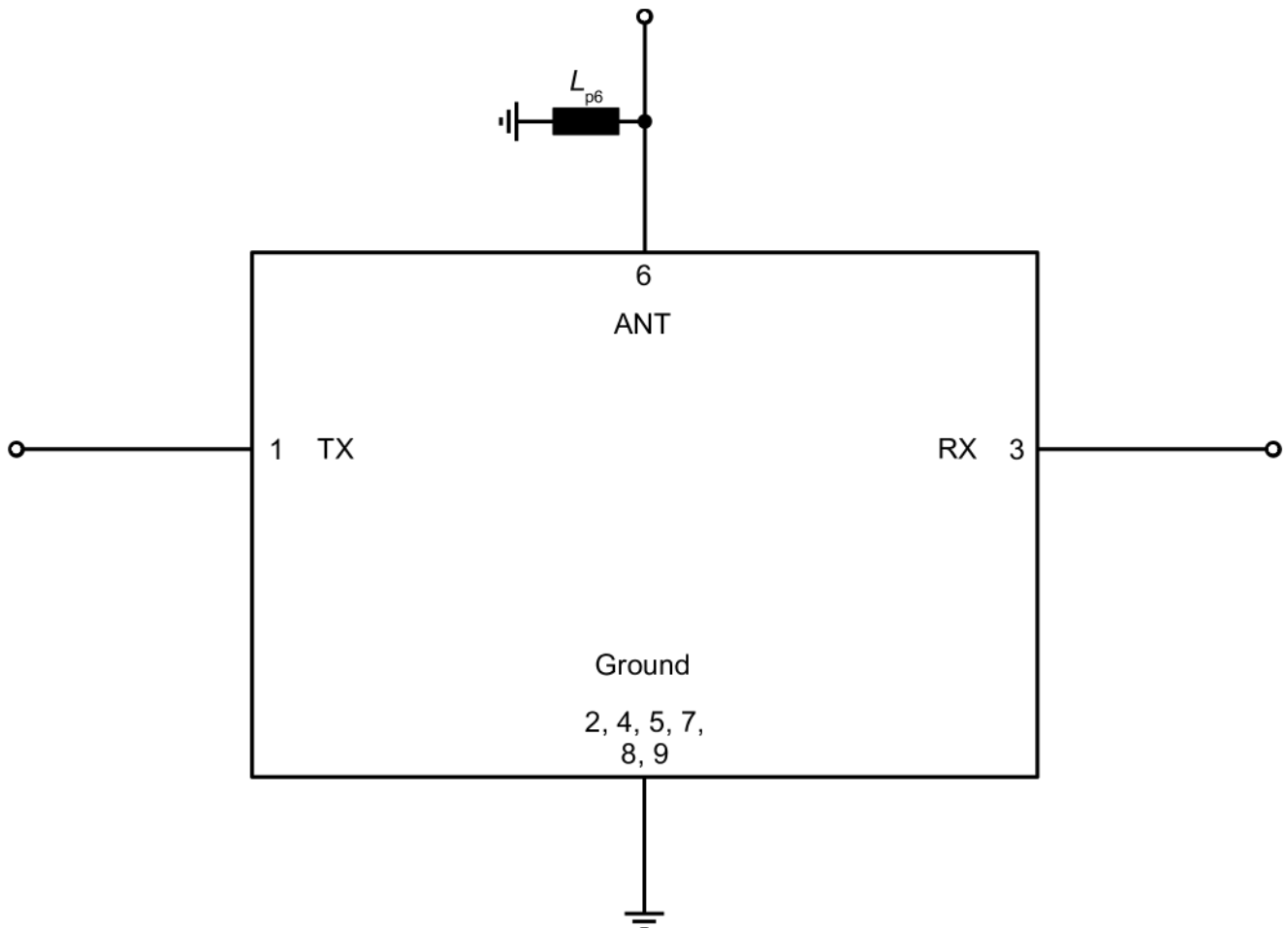

Figure 3: Schematic of matching circuit.

SAW components

B8005

SAW duplexer

751 / 782 MHz

Data sheet

6 Characteristics

6.1 TX – ANT

Temperature range for specification	T_{SPEC}	= -10 °C ... +85 °C
TX terminating impedance	Z_{TX}	= 50 Ω
ANT terminating impedance	Z_{ANT}	= 50 Ω with par. 17 nH ¹⁾
RX terminating impedance	Z_{RX}	= 50 Ω

Characteristics TX – ANT			min. for T_{SPEC}	typ. @ +25 °C	max. for T_{SPEC}	
Center frequency		f_C	—	751	—	MHz
Maximum insertion attenuation	746... 756	MHz	—	1.6	2.0	dB
Amplitude ripple (p-p)	746... 756	MHz	—	0.4	1.0	dB
Maximum VSWR		VSWR _{max}				
@ TX port	746... 756	MHz	—	1.5	1.8	
@ ANT port	746... 756	MHz	—	1.4	1.8	
Maximum error vector magnitude	748.5... 753.5	MHz	—	1.6	2.5	%
Minimum attenuation		α_{min}				
	10... 150	MHz	40	55	—	dB
	150... 350	MHz	35	45	—	dB
	350... 650	MHz	30	38	—	dB
	698... 716	MHz	35	38	—	dB
	716... 722	MHz	38	43	—	dB
	777... 787	MHz	54	58	—	dB
	788... 798	MHz	45	52	—	dB
	798... 849	MHz	35	43	—	dB
	1492... 1543	MHz	35	39	—	dB
	1554... 1574	MHz	35	39	—	dB
	1574... 1606	MHz	35	40	—	dB
	1710... 1770	MHz	35	40	—	dB
	1850... 1915	MHz	35	40	—	dB
	1920... 1980	MHz	35	40	—	dB
	2200... 2690	MHz	33	38	—	dB
	2690... 3800	MHz	25	43	—	dB
	5150... 5850	MHz	5	25	—	dB

¹⁾ See Sec. Matching circuit (p. 6).

²⁾ Error Vector Magnitude (EVM) based on definition in 3GPP TS 25.141.

SAW components

B8005

SAW duplexer

751 / 782 MHz

Data sheet

6.2 ANT – RX

Temperature range for specification	T_{SPEC}	= -10 °C ... +85 °C
TX terminating impedance	Z_{TX}	= 50 Ω
ANT terminating impedance	Z_{ANT}	= 50 Ω with par. 17 nH ¹⁾
RX terminating impedance	Z_{RX}	= 50 Ω

Characteristics ANT – RX			min. for T_{SPEC}	typ. @ +25 °C	max. for T_{SPEC}	
Center frequency		f_C	—	782	—	MHz
Maximum insertion attenuation	777... 787	MHz	—	1.9	2.5	dB
Amplitude ripple (p-p)	777... 787	MHz	—	0.6	1.5	dB
Maximum VSWR						
@ ANT port	777... 787	MHz	—	1.5	1.8	
@ RX port	777... 787	MHz	—	1.6	1.8	
Maximum error vector magnitude	779.5... 784.5	MHz	—	2.2	3.0	%
Minimum attenuation						
	10... 150	MHz	40	55	—	dB
	150... 350	MHz	35	45	—	dB
	350... 650	MHz	30	37	—	dB
	728... 746	MHz	35	50	—	dB
	746... 756	MHz	50	57	—	dB
	758... 768	MHz	28	30	—	dB
	808... 818	MHz	35	47	—	dB
	859... 894	MHz	35	45	—	dB
	1452... 1492	MHz	40	52	—	dB
	1554... 1574	MHz	40	52	—	dB
	1574... 1606	MHz	45	52	—	dB
	1670... 1675	MHz	40	50	—	dB
	1930... 1995	MHz	40	48	—	dB
	2110... 2170	MHz	40	49	—	dB
	2300... 2361	MHz	28	33	—	dB
	2361... 2690	MHz	30	42	—	dB
	3300... 3800	MHz	15	22	—	dB
	5150... 5850	MHz	5	12	—	dB

¹⁾ See Sec. Matching circuit (p. 6).

²⁾ Error Vector Magnitude (EVM) based on definition in 3GPP TS 25.141.

SAW components

B8005

SAW duplexer

751 / 782 MHz

Data sheet

6.3 TX – RX

Temperature range for specification	T_{SPEC}	= -10 °C ... +85 °C
TX terminating impedance	Z_{TX}	= 50 Ω
ANT terminating impedance	Z_{ANT}	= 50 Ω with par. 17 nH ¹⁾
RX terminating impedance	Z_{RX}	= 50 Ω

Characteristics TX – RX			min. for T_{SPEC}	typ. @ +25 °C	max. for T_{SPEC}	
Minimum isolation	α_{min}	746... 756 MHz	50	60	—	dB
		777... 787 MHz	52	58	—	dB

¹⁾ See Sec. Matching circuit (p. 6).

SAW components

B8005

SAW duplexer

751 / 782 MHz

Data sheet

7 Maximum ratings

Operable temperature	$T_{OP} = -40\text{ °C} \dots +95\text{ °C}$	
Storage temperature	$T_{STG}^{1)} = -40\text{ °C} \dots +95\text{ °C}$	
DC voltage	$ V_{DC} ^{2)} = 0\text{ V}$	
ESD voltage		
	$V_{ESD}^{3)} = 50\text{ V}$	Machine model.
	$V_{ESD}^{4)} = 100\text{ V}$	Human body model.
Input power	P_{IN}	
@ TX port: 746 ... 756 MHz	28 dBm ⁵⁾	5 MHz LTE downlink signal (25 RB) for 100000 h @ 55 °C. P_{IN} 28 dBm average – 39 dBm peak. Source and load impedance 50Ω.
@ TX port: other frequency ranges	10 dBm	Source and load impedance 50Ω.
Operating lifetime with output power at antenna 746 ... 756 MHz	$P_{OUT}^{6)} = 24\text{ dBm}$	Continuous wave for 100000 h @ 55 °C. Source and load impedance 50Ω.

¹⁾ Not valid for packaging material. Storage temperature for packaging material is -25 °C to +40 °C.

²⁾ In case of applied DC voltage blocking capacitors are mandatory.

³⁾ According to JESD22-A115B (MM – Machine Model), 10 negative & 10 positive pulses.

⁴⁾ According to JESD22-A114F (HBM – Human Body Model), 1 negative & 1 positive pulse.

⁵⁾ Expected lifetime according to power durability tests, and wear out models.

⁶⁾ According to accelerated high temperature operating life (HTOL) test.

Data sheet

8 Transmission coefficients

8.1 TX – ANT

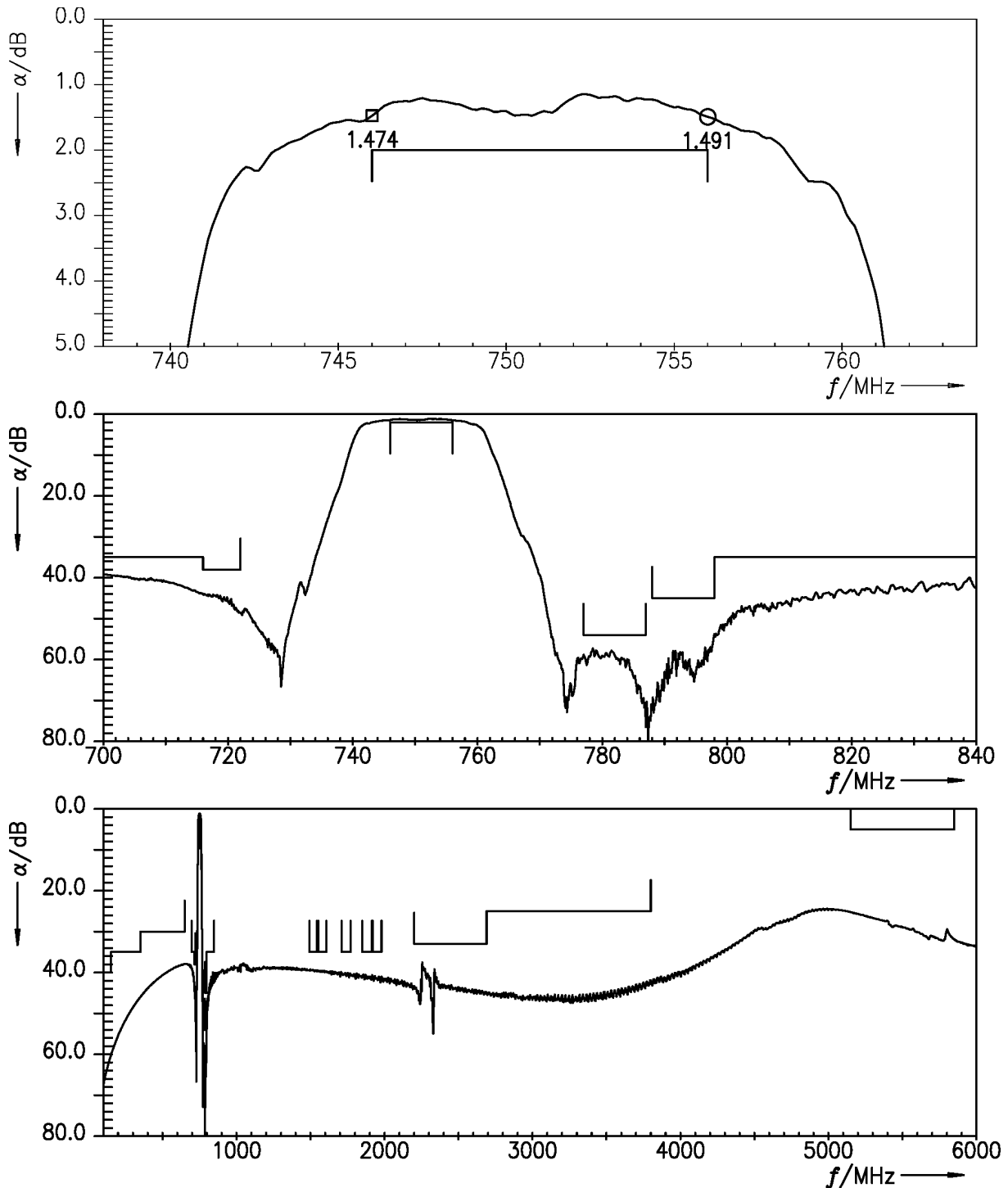

Figure 4: Attenuation TX – ANT.

SAW components **B8005**
SAW duplexer **751 / 782 MHz**

Data sheet

8.2 ANT – RX

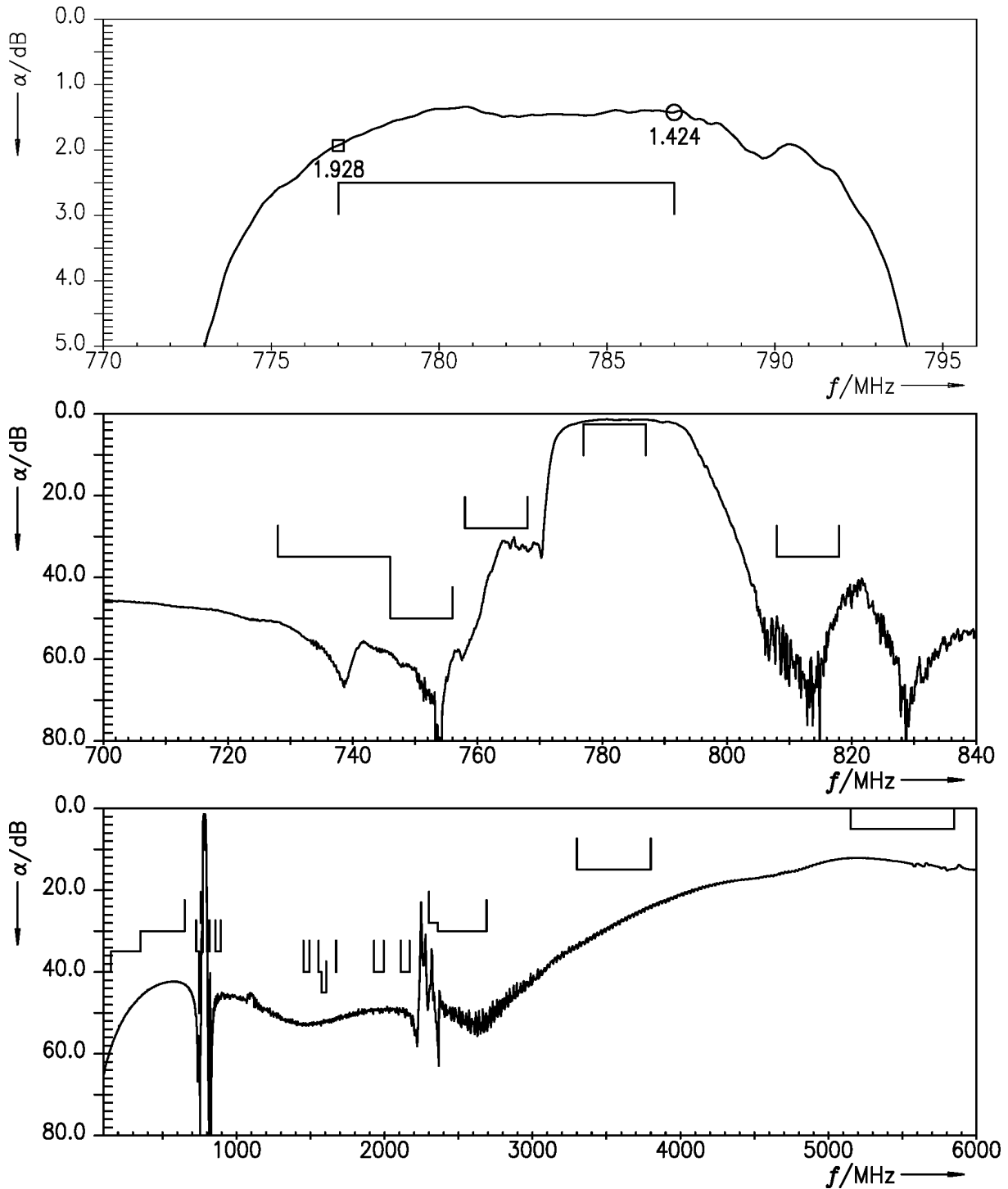

Figure 5: Attenuation ANT – RX.

SAW components **B8005**
SAW duplexer **751 / 782 MHz**

Data sheet

8.3 TX – RX

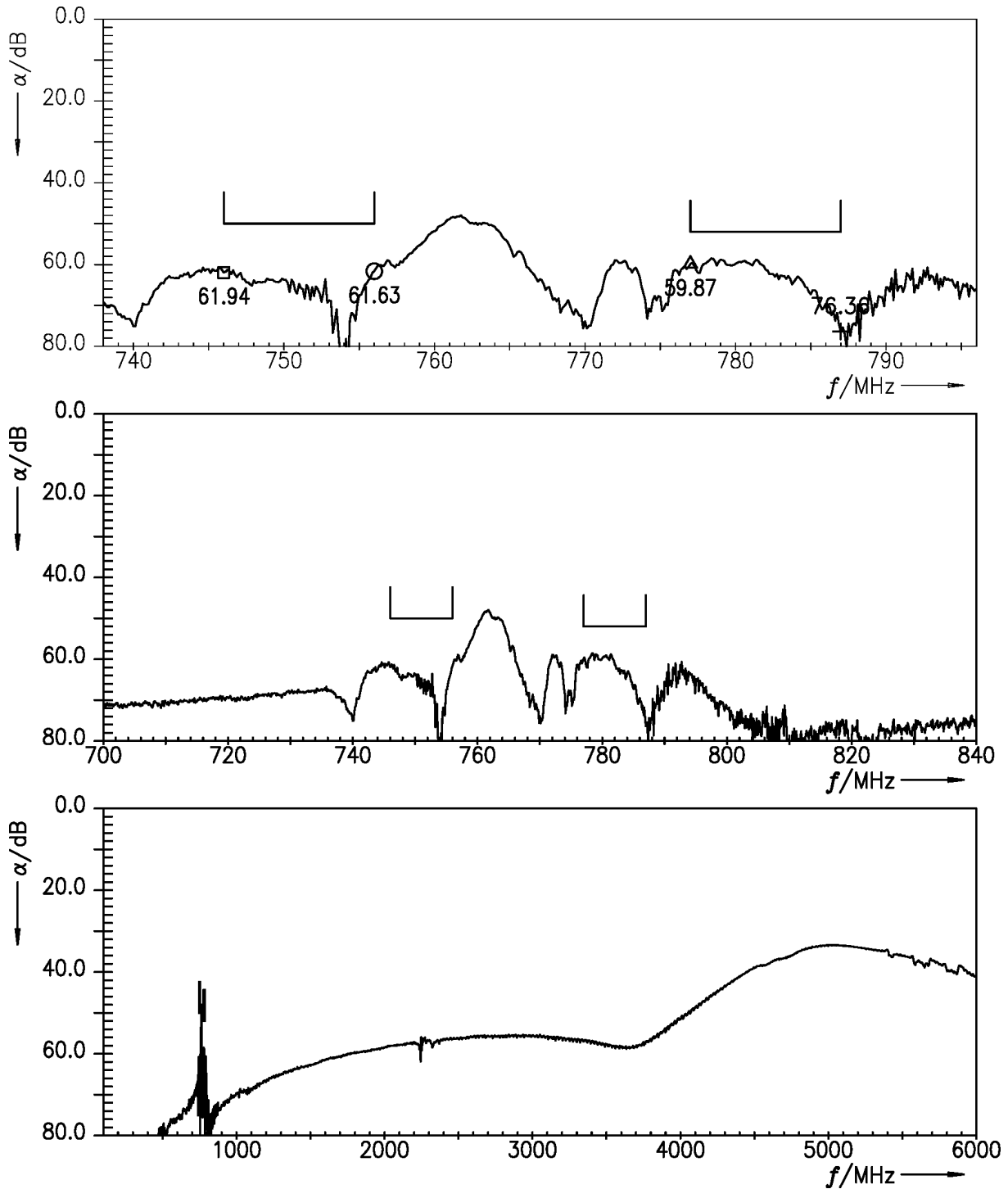

Figure 6: Isolation TX – RX.

Data sheet

9 Reflection coefficients

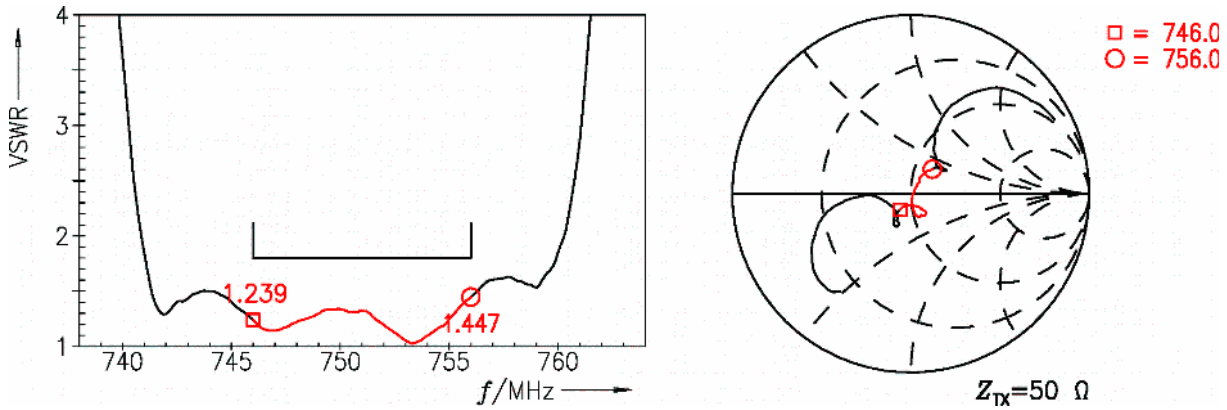

Figure 7: Reflection coefficient at TX port.

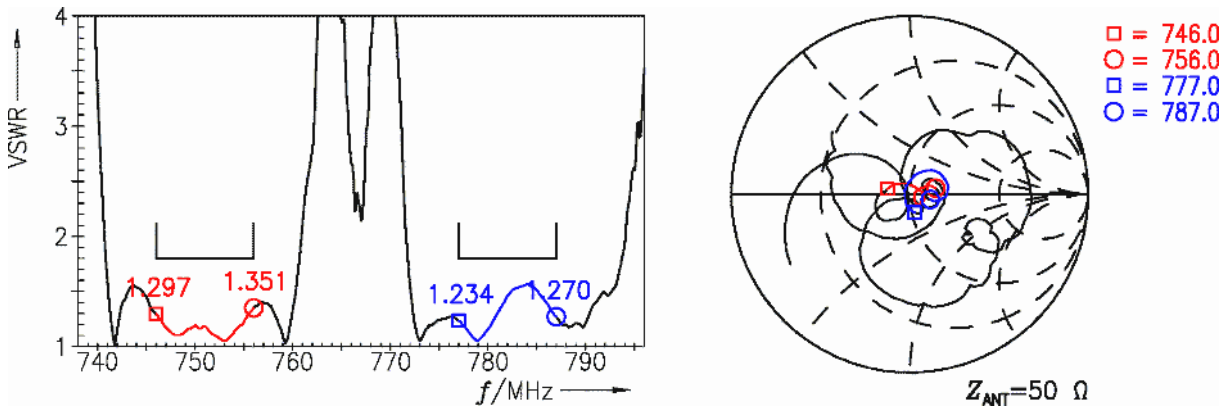

Figure 8: Reflection coefficient at ANT port.

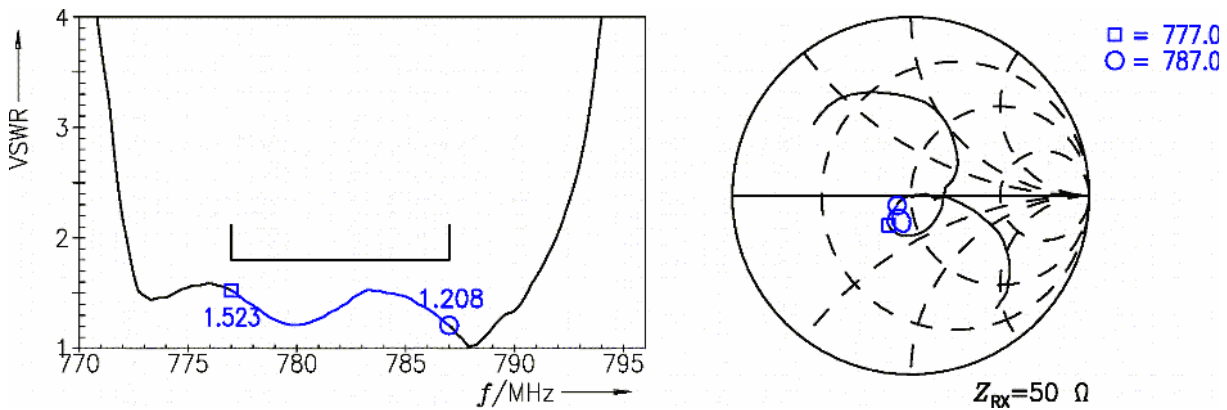

Figure 9: Reflection coefficient at RX port.

SAW components	B8005
SAW duplexer	751 / 782 MHz

Data sheet

10 EVMs

10.1 TX – ANT

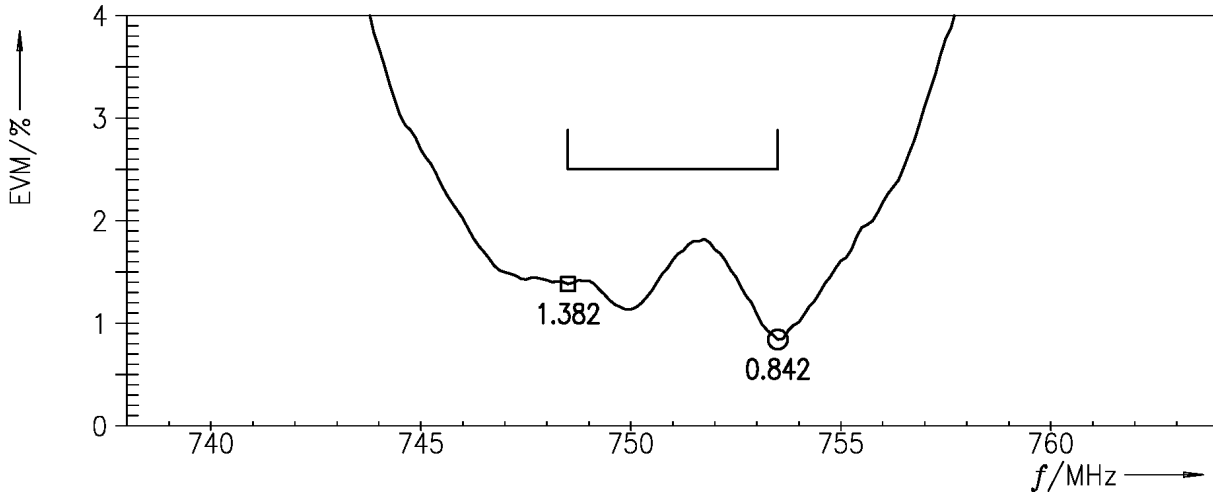
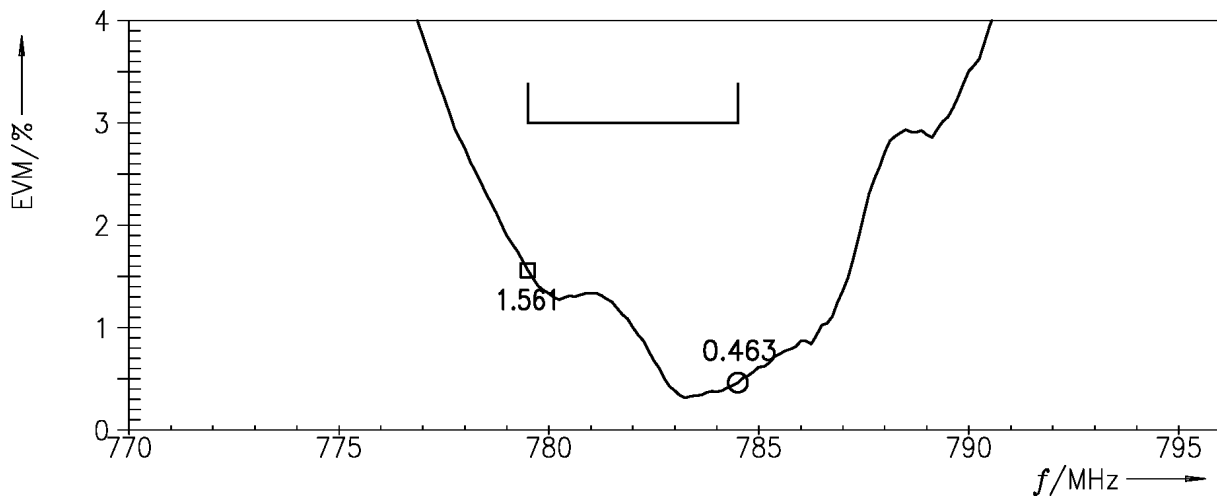

Figure 10: Error vector magnitude TX – ANT.

Data sheet

10.2 ANT – RX

**Figure 11:** Error vector magnitude ANT – RX.

SAW components **B8005**

SAW duplexer **751 / 782 MHz**

Data sheet

11 Packing material

11.1 Tape

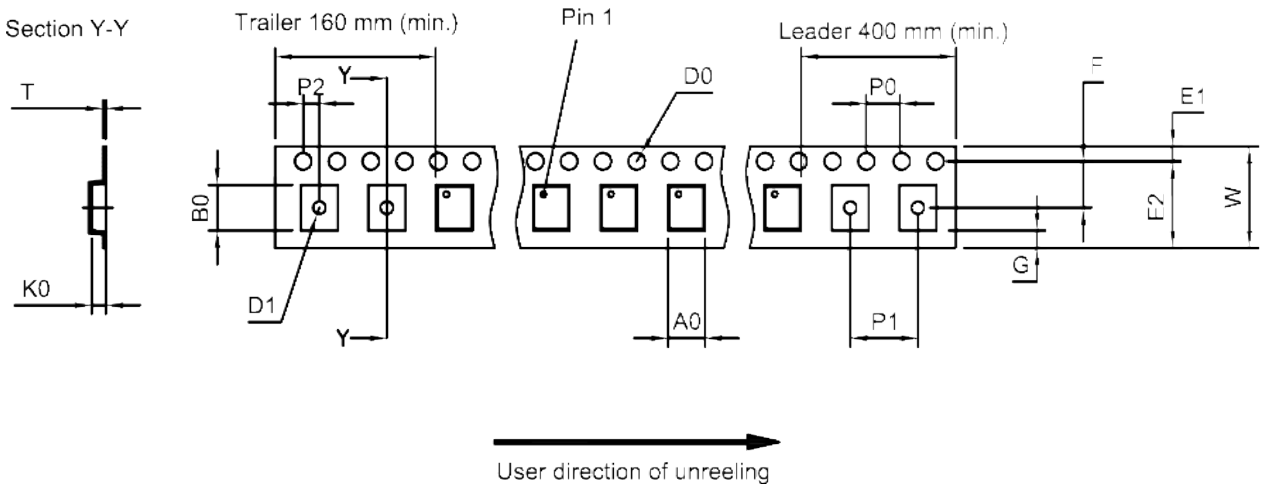

Figure 12: Drawing of tape (first-angle projection) with tape dimensions according to Table 1.

A ₀	2.25±0.05 mm	E ₂	6.25 mm (min.)	P ₁	4.0±0.1 mm
B ₀	2.75±0.05 mm	F	3.5±0.05 mm	P ₂	2.0±0.05 mm
D ₀	1.5+0.1/-0 mm	G	0.75 mm (min.)	T	0.25±0.03 mm
D ₁	1.0 mm (min.)	K ₀	0.6±0.05 mm	W	8.0+0.3/-0.1 mm
E ₁	1.75±0.1 mm	P ₀	4.0±0.1 mm		

Table 1: Tape dimensions.

SAW components	B8005
SAW duplexer	751 / 782 MHz

Data sheet

11.2 Reel with diameter of 180 mm

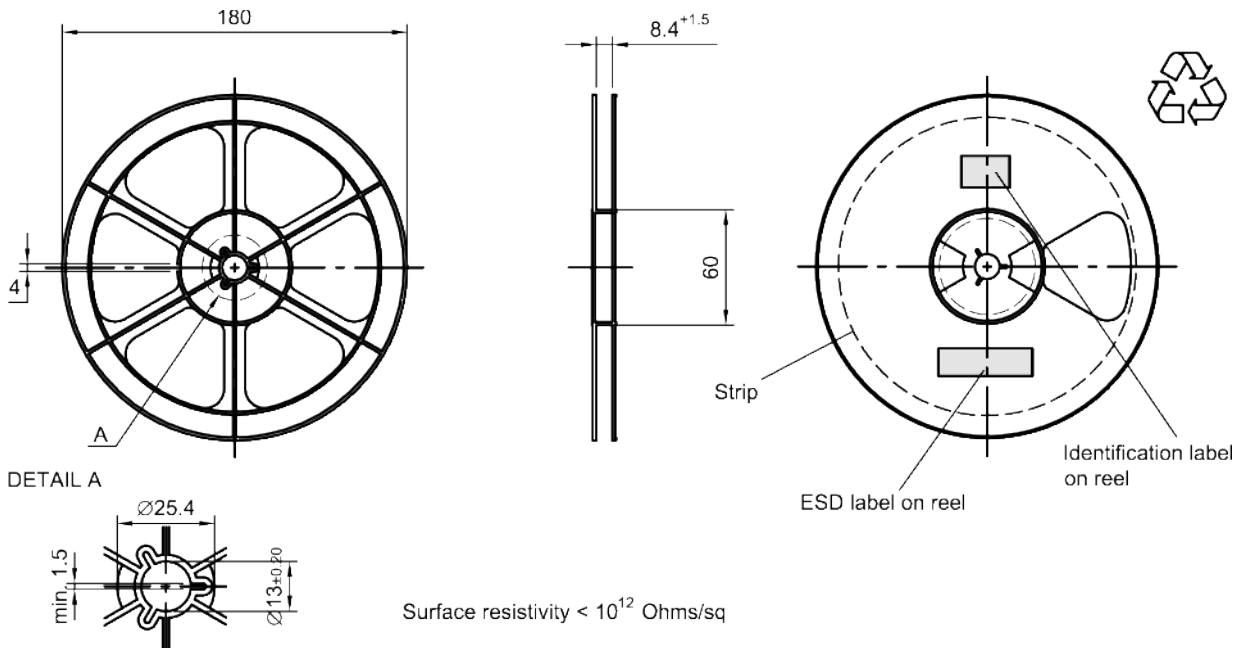

Figure 13: Drawing of reel (first-angle projection) with diameter of 180 mm.

Dimensions [mm]

X = 220+5

Y = 235+5

Sealing area 10±3

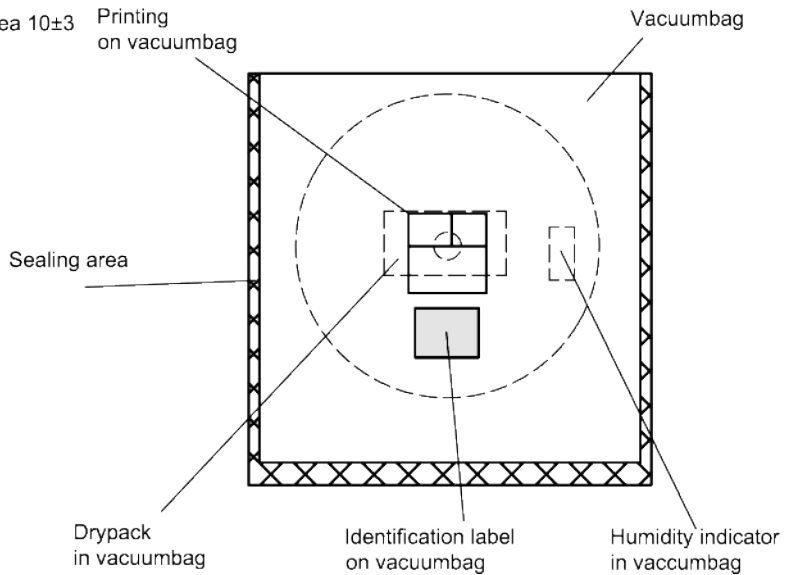

Figure 14: Drawing of moisture barrier bag (MBB) for reel with diameter of 180 mm.

SAW components **B8005**
SAW duplexer **751 / 782 MHz**

Data sheet

Dimensions [mm]
 L = 188
 B = 188
 H = 30
 Tolerance ±5

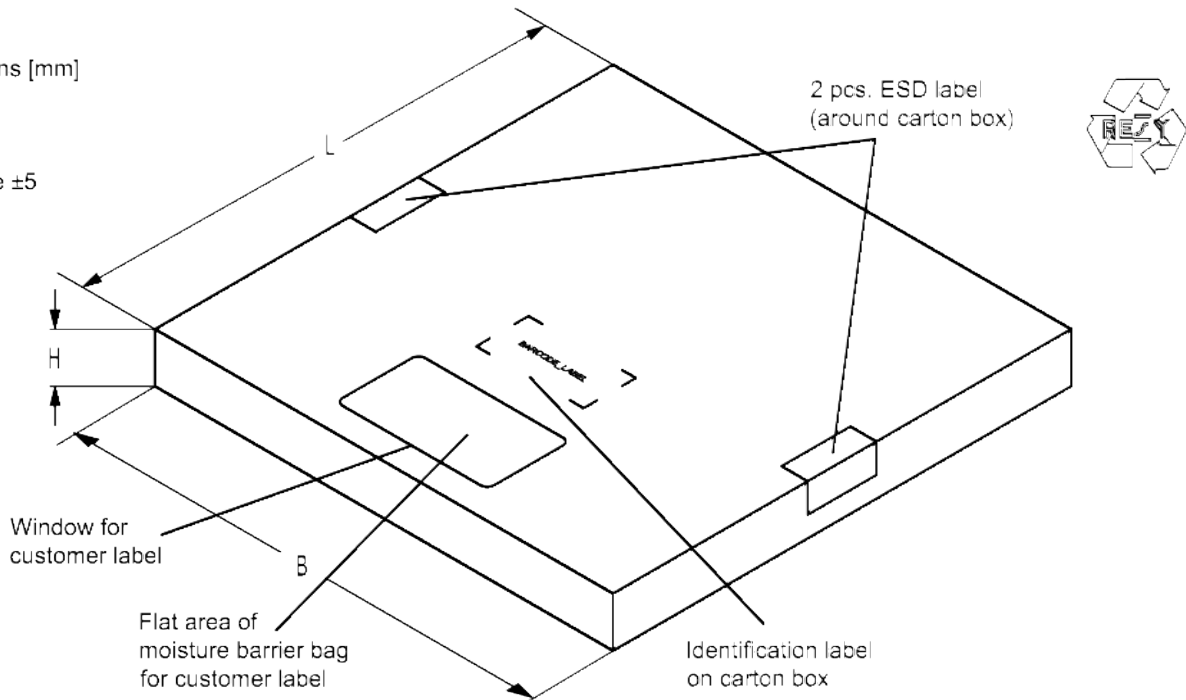

Figure 15: Drawing of folding box for reel with diameter of 180 mm.

11.3 Reel with diameter of 330 mm

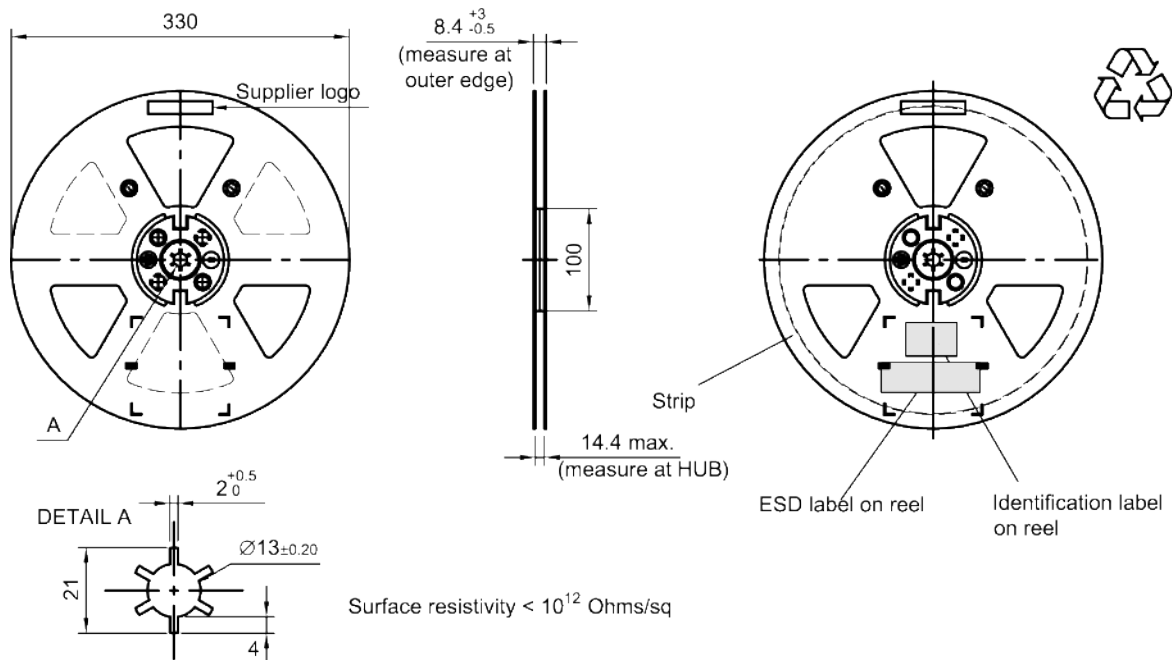

Figure 16: Drawing of reel (first-angle projection) with diameter of 330 mm.

SAW components **B8005**
SAW duplexer **751 / 782 MHz**

Data sheet

Dimensions [mm]
 X = 400+5
 Y = 418+5
 Sealing area 10±3

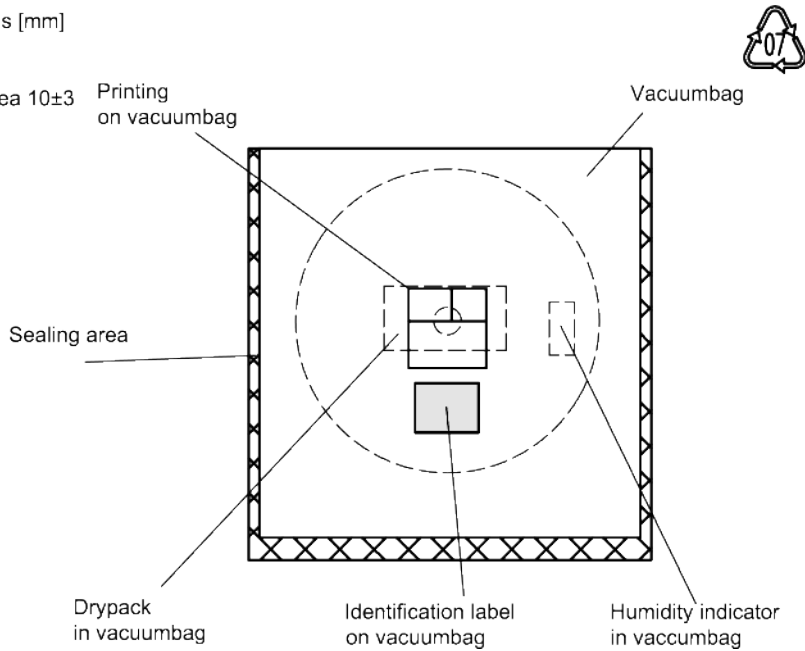

Figure 17: Drawing of moisture barrier bag (MBB) for reel with diameter of 330 mm.

Dimensions [mm]
 L = 335
 B = 338
 H = 36 (for 8 mm tape width)
 40 (for 12 mm tape width)
 Tolerance ±5

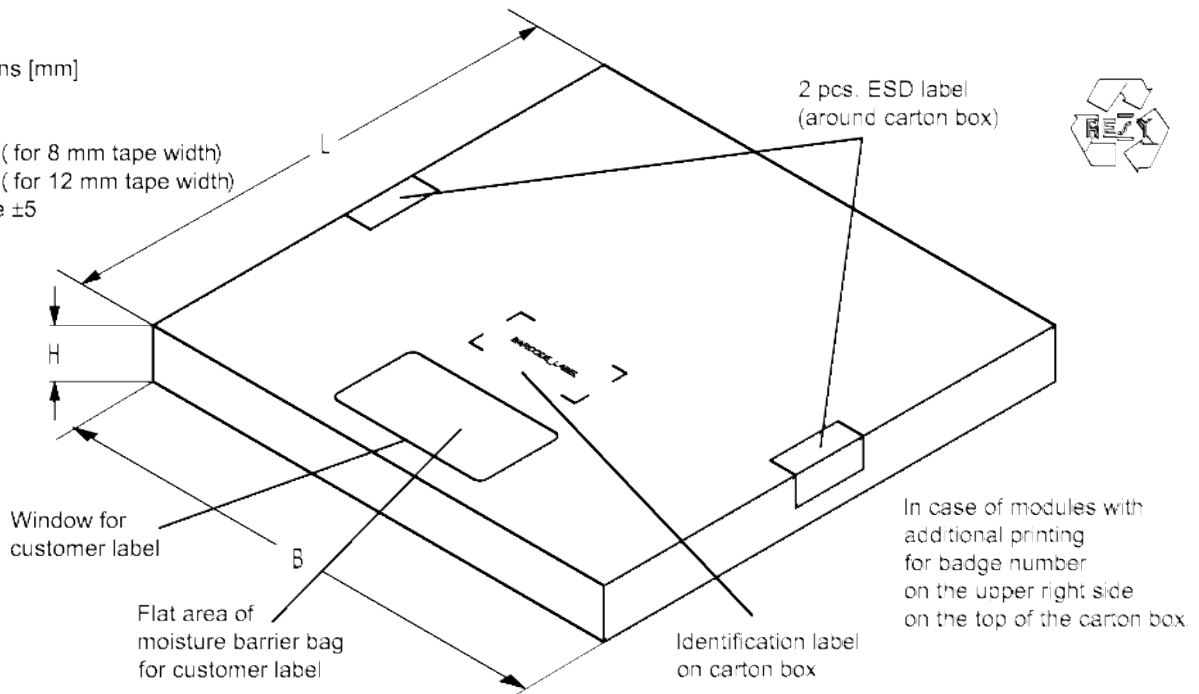

Figure 18: Drawing of folding box for reel with diameter of 330 mm.

SAW components

B8005

SAW duplexer

751 / 782 MHz

Data sheet

12 Marking

Products are marked with product type number and lot number encoded according to Table 2:

■ Type number:

The 4 digit type number of the ordering code, e.g., B3xxxxB**1234**xxxx,
is encoded by a special BASE32 code into a 3 digit marking.

Example of decoding	type number marking on device	in decimal code.
	16J	1234
	$1 \times 32^2 + 6 \times 32^1 + 18 (=J) \times 32^0$	1234

The BASE32 code for product type B8005 is 7T5.

■ Lot number:

The last 5 digits of the lot number, e.g., **12345**,
are encoded based on a special BASE47 code into a 3 digit marking.

Example of decoding lot number marking on device		in decimal code.
	5UY	12345
	$5 \times 47^2 + 27 (=U) \times 47^1 + 31 (=Y) \times 47^0$	12345

Adopted BASE32 code for type number			
Decimal value	Base32 code	Decimal value	Base32 code
0	0	16	G
1	1	17	H
2	2	18	J
3	3	19	K
4	4	20	M
5	5	21	N
6	6	22	P
7	7	23	Q
8	8	24	R
9	9	25	S
10	A	26	T
11	B	27	V
12	C	28	W
13	D	29	X
14	E	30	Y
15	F	31	Z

Adopted BASE47 code for lot number			
Decimal value	Base47 code	Decimal value	Base47 code
0	0	24	R
1	1	25	S
2	2	26	T
3	3	27	U
4	4	28	V
5	5	29	W
6	6	30	X
7	7	31	Y
8	8	32	Z
9	9	33	b
10	A	34	d
11	B	35	f
12	C	36	h
13	D	37	n
14	E	38	r
15	F	39	t
16	G	40	v
17	H	41	\
18	J	42	?
19	K	43	{
20	L	44	}
21	M	45	<
22	N	46	>
23	P		

Table 2: Lists for encoding and decoding of marking.

Data sheet

13 Soldering profile

The recommended soldering process is in accordance with IEC 60068-2-58 – 3rd edit and IPC/JEDEC J-STD-020B.

ramp rate	≤ 3 K/s
preheat	125 °C to 220 °C, 150 s to 210 s, 0.4 K/s to 1.0 K/s
$T > 220$ °C	30 s to 70 s
$T > 230$ °C	min. 10 s
$T > 245$ °C	max. 20 s
$T \geq 255$ °C	–
peak temperature T_{peak}	250 °C +0/-5 °C
wetting temperature T_{min}	230 °C +5/-0 °C for 10 s ± 1 s
cooling rate	≤ 3 K/s
soldering temperature T	measured at solder pads

Table 3: Characteristics of recommended soldering profile for lead-free solder (Sn95.5Ag3.8Cu0.7).

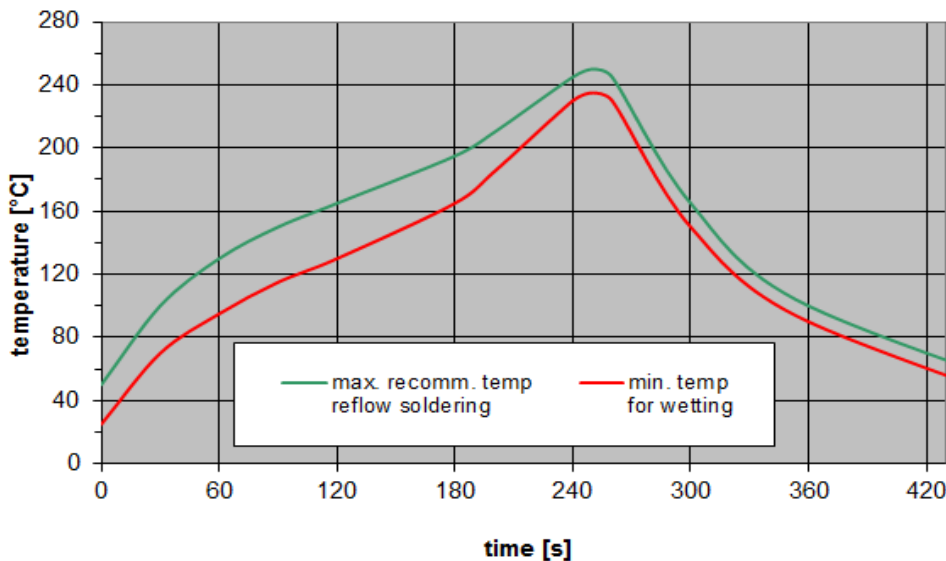

Figure 19: Recommended reflow profile for convection and infrared soldering – lead-free solder.

Data sheet

14 Annotations

14.1 Matching coils

See TDK inductor pdf-catalog <http://www.tdk.co.jp/tefe02/coil.htm#aname1> and Data Library for circuit simulation <http://www.tdk.co.jp/etvcl/index.htm>.

14.2 RoHS compatibility

ROHS-compatible means that products are compatible with the requirements according to Art. 4 (substance restrictions) of Directive 2011/65/EU of the European Parliament and of the Council of June 8th, 2011, on the restriction of the use of certain hazardous substances in electrical and electronic equipment ("Directive") with due regard to the application of exemptions as per Annex III of the Directive in certain cases.

14.3 Scattering parameters (S-parameters)

The pin/port assignment is available in the headers of the S-parameter files. Please contact your local RF360 sales office.

14.4 Ordering codes and packing units

Ordering code	Packing unit
B39781B8005P810	5000 pcs

Table 4: Ordering codes and packing units.

Data sheet

15 Cautions and warnings

15.1 Display of ordering codes for RF360 products

The ordering code for one and the same product can be represented differently in data sheets, data books, other publications and the website of RF360, or in order-related documents such as shipping notes, order confirmations and product labels. The varying representations of the ordering codes are due to different processes employed and do not affect the specifications of the respective products. Detailed information can be found on the Internet under www.rf360jv.com/orderingcodes.

15.2 Material information

Due to technical requirements components may contain dangerous substances. For information on the type in question please also contact one of our sales offices.

For information on recycling of tapes and reels please contact one of our sales offices.

15.3 Moldability

Before using in overmolding environment, please contact your local RF360 sales office.

15.4 Package information

Landing area

The printed circuit board (PCB) land pattern (landing area) shown is based on RF360 internal development and empirical data and illustrated for example purposes, only. As customers' SMD assembly processes may have a plenty of variants and influence factors which are not under control or knowledge of RF360, additional careful process development on customer side is necessary and strongly recommended in order to achieve best soldering results tailored to the particular customer needs.

Dimensions

Unless otherwise specified all dimensions are understood using unit millimeter (mm).

Dimensions do not include burrs.

Projection method

Unless otherwise specified first-angle projection is applied.

Important notes

The following applies to all products named in this publication:

1. Some parts of this publication contain **statements about the suitability of our products for certain areas of application**. These statements are based on our knowledge of typical requirements that are often placed on our products in the areas of application concerned. We nevertheless expressly point out **that such statements cannot be regarded as binding statements about the suitability of our products for a particular customer application**. As a rule, RF360 Europe GmbH and its affiliates are either unfamiliar with individual customer applications or less familiar with them than the customers themselves. For these reasons, it is always ultimately incumbent on the customer to check and decide whether an RF360 product with the properties described in the product specification is suitable for use in a particular customer application.
2. We also point out that **in individual cases, a malfunction of electronic components or failure before the end of their usual service life cannot be completely ruled out in the current state of the art, even if they are operated as specified**. In customer applications requiring a very high level of operational safety and especially in customer applications in which the malfunction or failure of an electronic component could endanger human life or health (e.g. in accident prevention or life-saving systems), it must therefore be ensured by means of suitable design of the customer application or other action taken by the customer (e.g. installation of protective circuitry or redundancy) that no injury or damage is sustained by third parties in the event of malfunction or failure of an electronic component.
3. **The warnings, cautions and product-specific notes must be observed.**
4. In order to satisfy certain technical requirements, **some of the products described in this publication may contain substances subject to restrictions in certain jurisdictions (e.g. because they are classed as hazardous)**. Useful information on this will be found in our Material Data Sheets on the Internet (www.rf360jv.com/material). Should you have any more detailed questions, please contact our sales offices.
5. We constantly strive to improve our products. Consequently, **the products described in this publication may change from time to time**. The same is true of the corresponding product specifications. Please check therefore to what extent product descriptions and specifications contained in this publication are still applicable before or when you place an order. We also **reserve the right to discontinue production and delivery of products**. Consequently, we cannot guarantee that all products named in this publication will always be available.
The aforementioned does not apply in the case of individual agreements deviating from the foregoing for customer-specific products.