

© 1963 BY AMP INCORPORATED. ALL RIGHTS RESERVED. AMP PRODUCTS COVERED BY PATENTS AND/OR PATENTS PENDING. APPROVED PER GOVT CONTRACT NO.

REVISIONS				
ZONE	LTR	DESCRIPTION	DATE	APPROVED
✓	M	REV. SEE PER 0600-3683-95	TA	10-95 J.WARNER
	N	ECO-08-020973	PY	11-08 JW

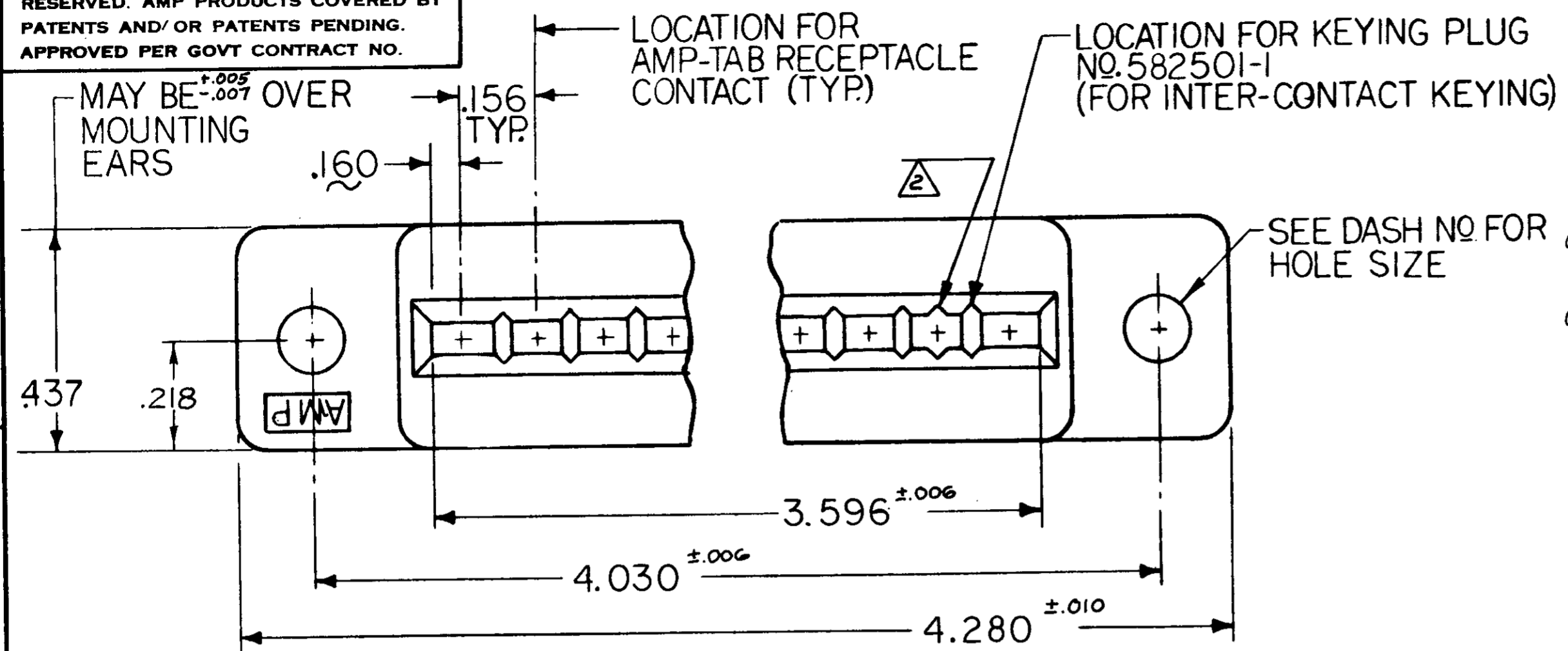

582695-1 I. AS SHOWN WITH .128 DIA. MOUNTING HOLES.  
~~582695-2 I. SAME AS -1 EXCEPT, WITH MOLDED-IN BUSHING (SEE DETAIL)~~  
~~582695-3 I. SAME AS -1 EXCEPT CAVITY IDENTIFICATION TO BE ALL NUMERIC USING ONLY EVEN NUMBERS. (SEE DETAIL "B")~~

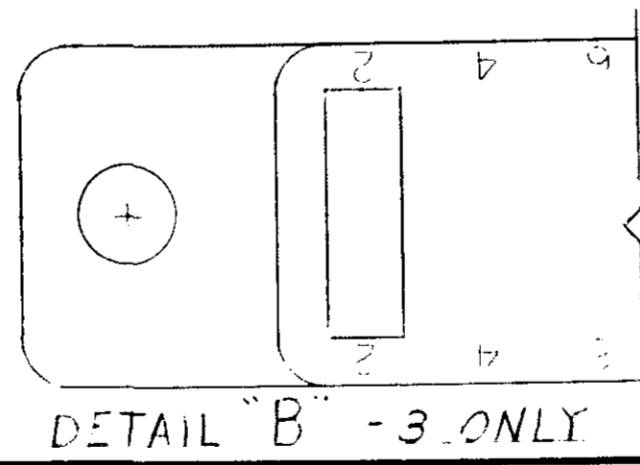
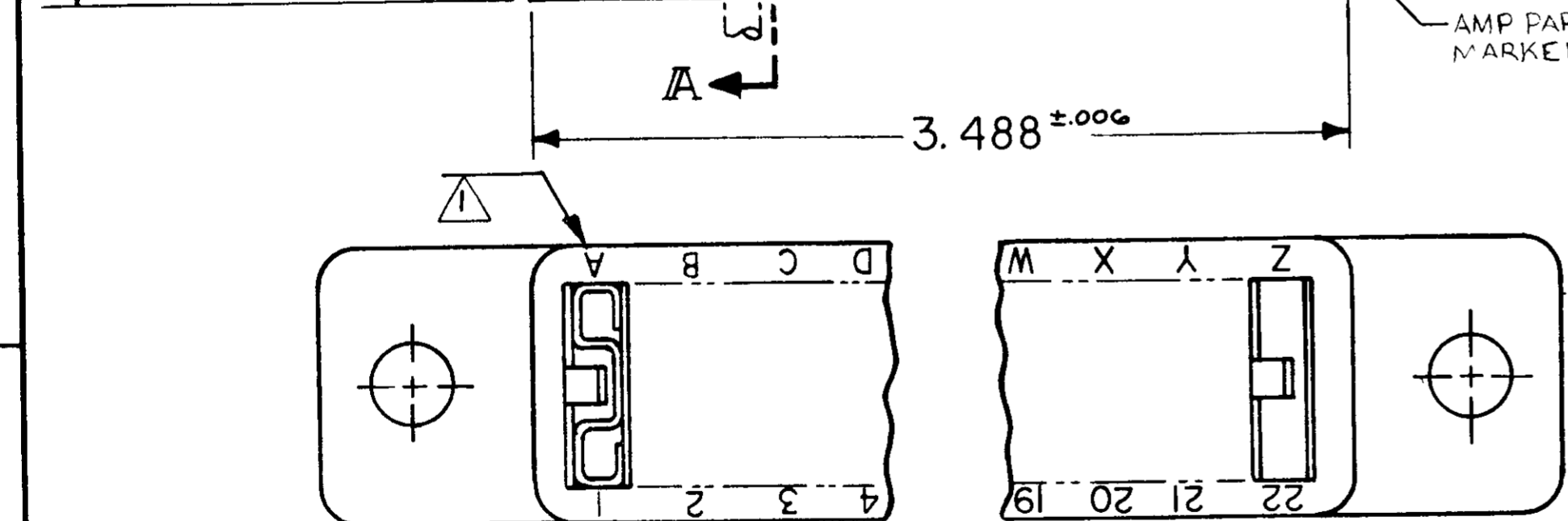
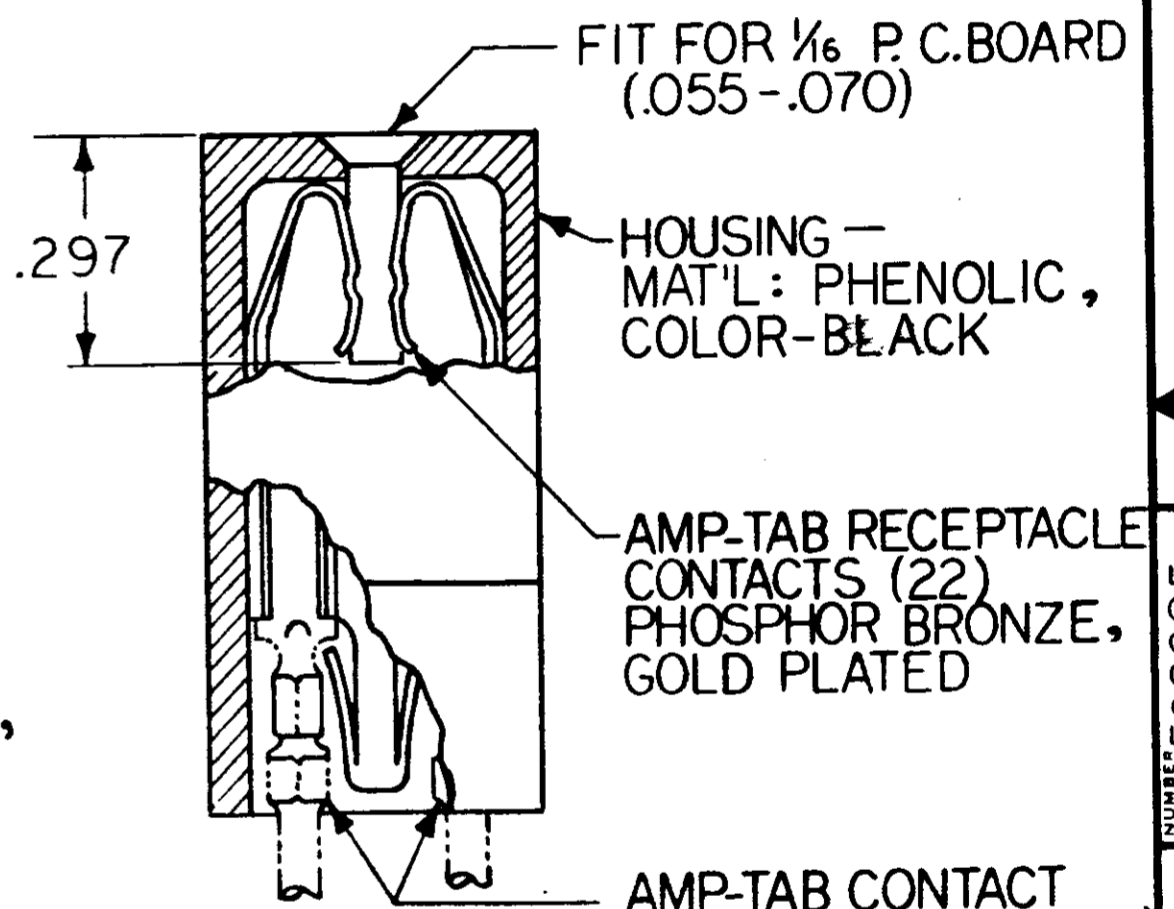
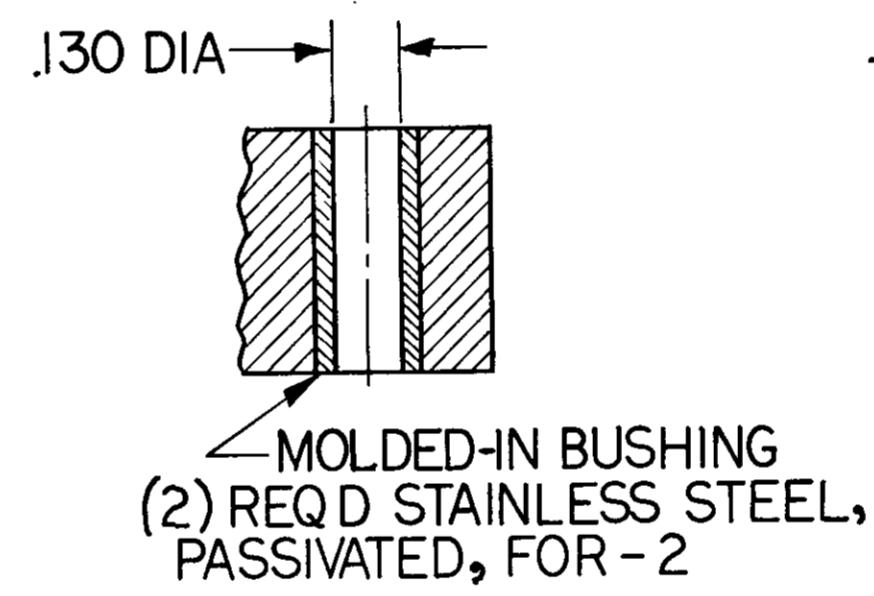
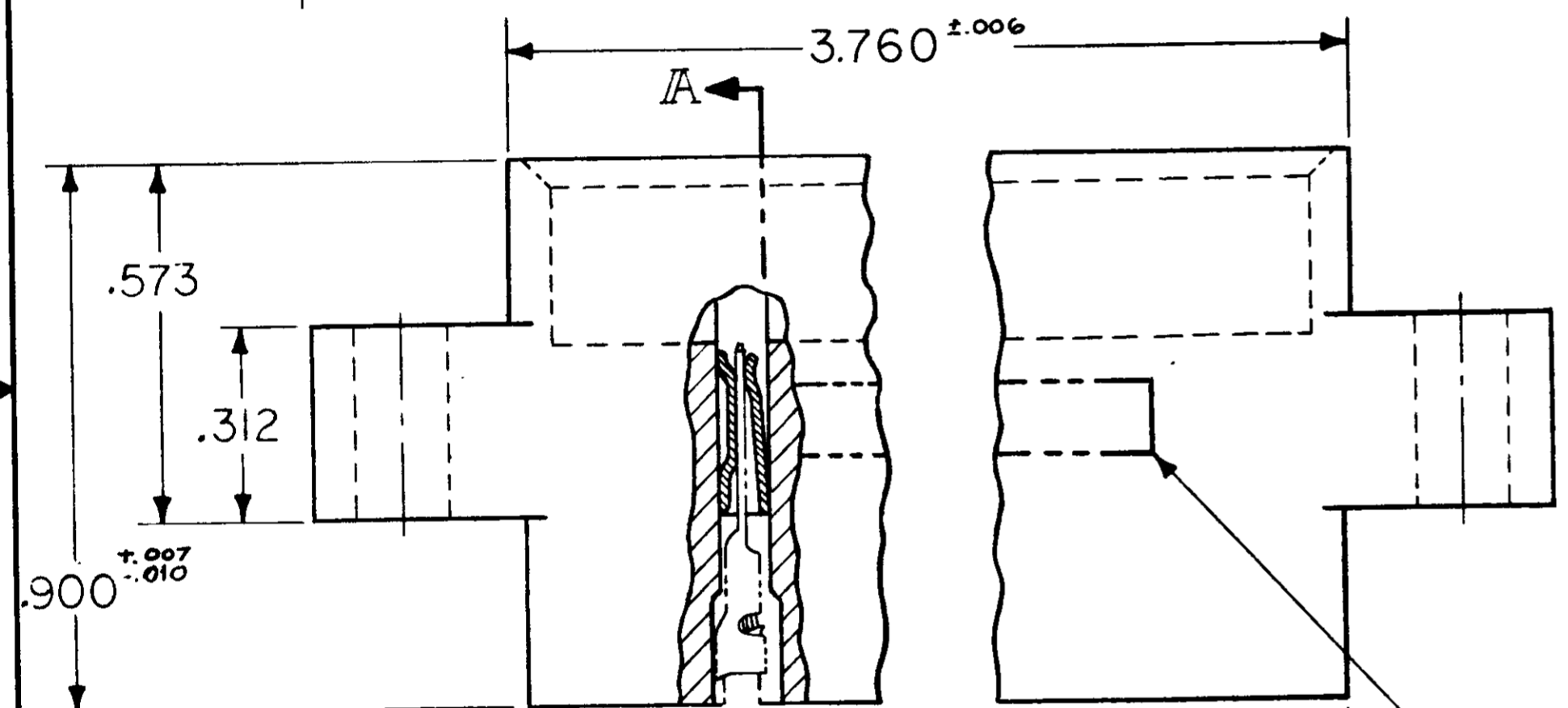

UNLESS OTHERWISE SPECIFIED DIMENSIONS ARE IN INCHES TOLERANCES ON		CONTRACT NO.		AMP INCORPORATED HARRISBURG, PENNSYLVANIA	
FRACTIONS	DECIMALS	ANGLES	DR	DATE	NAME
±	±.005	±	J. Asich		TRADE MARK
MATERIAL	SEE CALLOUT	HEAT TREAT	CHK	DATE	CONTRACT NO.
			S.S. Heide		AMP INCORPORATED
			DSGN ENGR		HARRISBURG, PENNSYLVANIA
			APPD		CONNECTOR, AMP-TAB, DUAL, 22 POS., .156 CTRS.
			DSGN APPD		
FINISH	SEE CALLOUT	OTHER APPD			
SIZE	CODE IDENT NO	NUMBER	REV		
C	00779	582695	N		
SCALE	4 - 1	WT	CALC	ACTUAL	SHEET

CUSTOMER DRAWING