

Seismic Center		±0.03	Group 1	Group 2	Group 3	
Cylinder		±0.03	Entry	X	X.X	X.XX
Coaxiality		±0.03	Tolerance	±0.1	±0.05	±0.03
Concentric		±0.03	Angle	±1.0°	±0.5°	±0.3°

REVISION		
NO.	CHANGE CONTENTS	CHANGE CAUSE

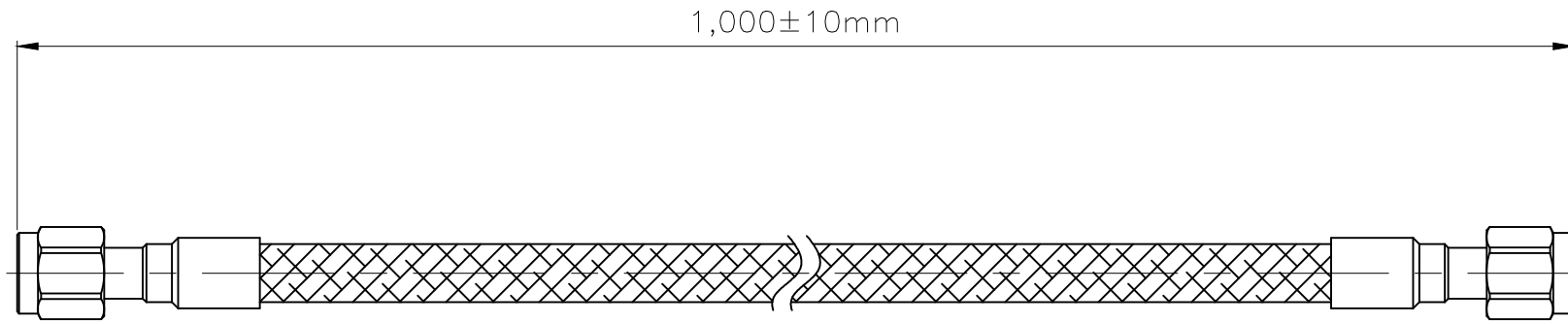

Connector P/N : 2P92MSH-002
[Old P/N : K(M)_SH40_01]

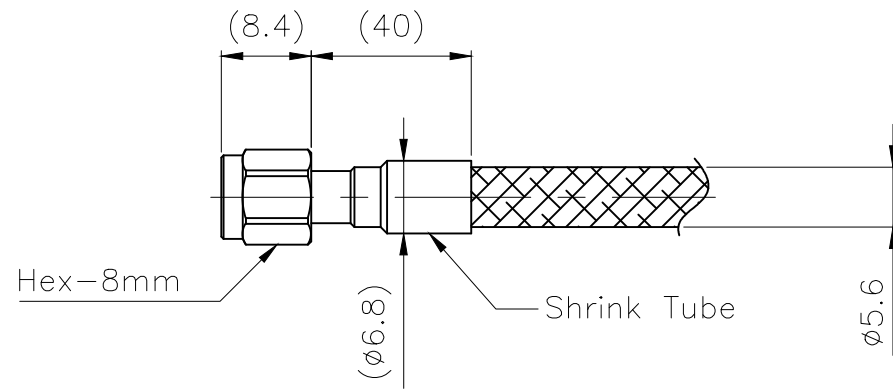

Cable P/N : 9A40



Specifications MIL-C-17 : Cable MIL-PRF-39012 : Connectors MIL-G-45204 : Gold Plating, Electrodeposited MIL-I-23053 : Insulation Sleeving etc. MIL-P-46179 : Plastic Molding etc. MIL-R-46198 : Resin, Polyimide etc.	Materials (Cable) 1. Cable Center Conductor Solid SPC (ASTM B 298) 2. Cable Dielectric Low Density PTFE in accordance with the applicable paragraph of MIL C 17 3. Cable Inner Shield SPC Flat Wire (ASTM B 298) 4. Cable Outer Shield SPC Round Wire (ASTM B 298) 5. Cable Jacket Ruggedized Aramid Yarn
Military Standards MIL-STD-202 : Test Method MIL-STD-810 : Test Method for Environmental MIL-STD-1344 : Test Method for Connectors	Cable Constriction
Materials (Connector) 1. Body Stainless Steel (ASTM A 582), Passivated Brass (C3604)(ASTM B 16), Au Plated 2. Center Conductor BeCu (C1720)(ASTM B 196), Au Plated 3. Insulator PEI0113 (ASTM D 5205) 4. Coupling Nut Stainless Steel (ASTM A 582), Passivated	Electrical Characteristics (Cable) 1. Impedance : 50Ω 2. Capacitance : 88 pF/m, 26.8 pF/ft 3. Velocity of Propagation : 77 % 4. Delay : 4.34 ns/m, 1.32 ns/ft 6. Insertion Loss : - 2.60dB/m @40GHz Typ. -2.86dB/m @40GHz Min. 7. RF Leakage : -100dB
Insertion loss graph (Cable) Insertion Loss per meter[m] Cable : 9A40 / 9540 	Mechanical Characteristics (Cable) 1. Minimum Bend Radius (One turn) : 25mm 2. Temperature Range : -50 / +125 3. Weight Nominal : 48.6 g/m
Insertion Loss per feet[FT] Cable : 9A40 / 9540 	Electrical Characteristics (Connector) 1. Impedance : 50Ω 2. Frequency : DC to 40GHz 3. VSWR : 1.30 : 1 @40GHz Typ. 1.35 : 1 @40GHz Max. 4. Insertion Loss : -0.10dB/EA @40GHz 5. RF Leakage : -100dB

MATERIAL			DRAW	DESIGN	CHECK	APPRO.	TITLE	2P92MSH-9A40-2P92MSH-1m	
FINISH			JH.Kang	/	SJ.Ahn	JM.Park	Sales Drawing		
TOLERANCE	Decimal	Angle	22.02.21		22.02.21	22.02.21	P/N	CAA6A6CBZ002	
SCALE	1/1	UNITmm	MODEL		Cable Ass'y				A4
REVISION	00	SHEET	1/1						