

Tolerances
 1-20=+/-0.2
 20-30=+/-0.3
 30-40=+/-0.4
 40-50=+/-0.5
 50-100=+/-0.75
 100-300=+/-1.5
 Angles=+/-1
 Dimensions are in Millimeters

Revisions Description/Approved/Date	Approved M.H.	Date 03/24/99
	Checked M.H.	Date 03/24/99
	Drawn K.R.E.	Date 03/23/99
NOTES (plating thickness in micro-inches): 1. Per QQ-B-626 2. Per QQ-S-764 3. Per QQ-C-530 4. Per QQ-B-750 5. Per MIL-P-19468 6. Per ZZ-R-765 7. Per WW-T-799 8. Gold pl. 50 min. over nickel pl. 50 min. over copper strike 9. Nickel pl. 100 min. over copper strike 10. Per QQ-P-35 11. Gold pl. 30 min. over nickel pl. 50 min. over copper strike		

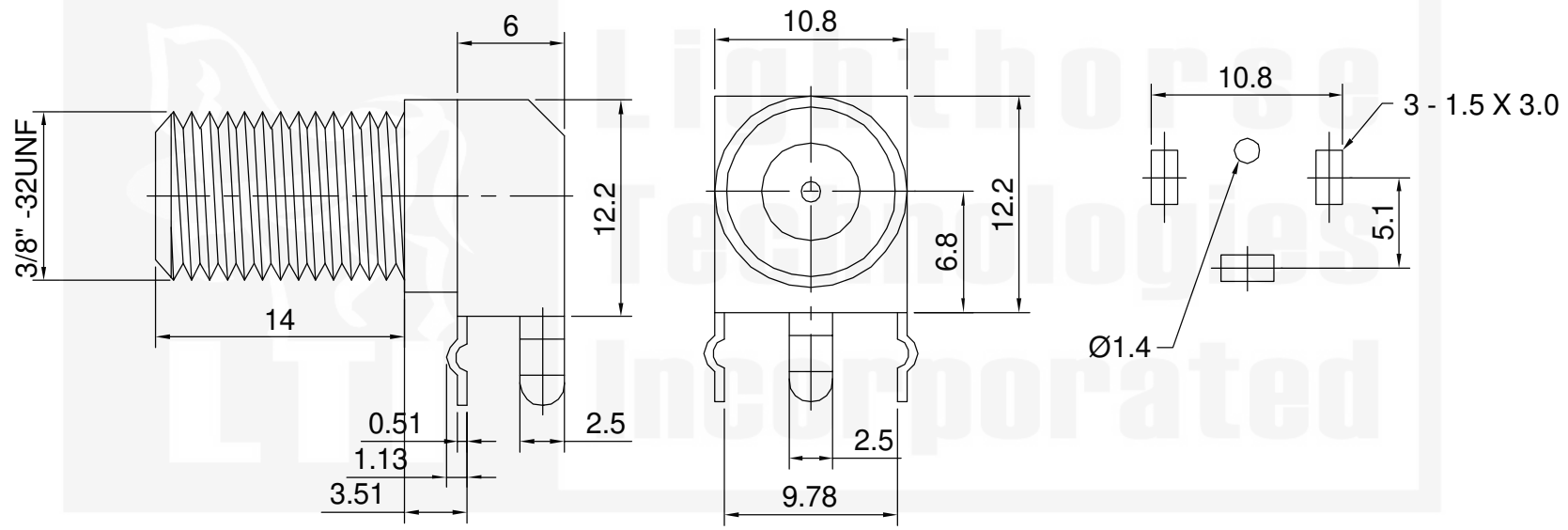

ITEM	MATERIAL	FINISH
Connector Body	Brass, Note 1	Nickel, Note 9
Center Contact: Female	Brass, Note 1	Nickel
Insulation	Polypropylene	None
Ferrule	--	--
Gasket	--	--
Hex Nut	--	--
Lock Washer	--	--

Light horse Technologies, Inc.
 4907 Morena Boulevard, #1411
 San Diego, California 92117

Part Number:
LTI-FLF54NP-3L

Description F right angle PCB jack, 3 leg version		
Scale 2:1	Drawing No. F/FLF54NP-3L	File Name FSF54-3L