

APPROVAL SHEET

RFLPF Series – 1005(0402)- RoHS Compliance

MULTILAYER CERAMIC LOW PASS FILTER

Halogens Free Product

1695 ~ 2180 MHz Working Frequency

P/N: RFLPF1005040F0T

*Contents in this sheet are subject to change without prior notice.

Approval sheet

FEATURES

1. Miniature footprint: 1.0 X 0.5 X 0.4 mm³.
2. Low Profile Thickness
3. Low Insertion loss
4. LTCC process

APPLICATIONS

1. 1695~2180 MHz Working Frequency.

CONSTRUCTION

Top view

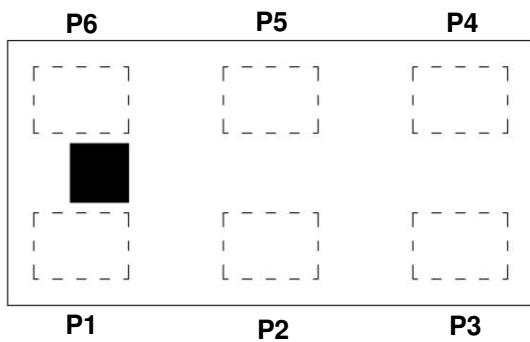

PIN	Connection
1	*NC
2	GND
3	*NC
4	I/O port
5	GND
6	I/O port

*NC : No connect.

DIMENSIONS

Figure	Symbol	Dimension (mm)
Top view 	L	1.00 ± 0.10
	W	0.50 ± 0.10
	T	0.50 max.
Side view 	A	0.18 ± 0.05
	B	0.18 ± 0.05
	C	0.05 ± 0.05
Bottom view 	D	0.125 ± 0.05
	E	0.15 ± 0.05
	F	0.05 ± 0.05

ELECTRICAL CHARACTERISTICS

RFLPF1005040F0T	Specification
Frequency Range	1695 ~ 2180 MHz
Insertion Loss	0.6 dB max. at 25 °C 0.8 dB max. at - 40 ~ + 85 °C
Attenuation	20 dB min. @ 3350 ~ 4360 MHz 45 dB min. @ 5085 ~ 6540 MHz
Return Loss	10 dB min.
Characteristics Impedance	50 Ω
Moisture sensitivity levels	LEVEL 1 (Refer to : IPC/JEDEC J-STD-020)

Operating & Storage Condition (Component)

Operation Temperature Range: -40 ~ +85 °C

Storage Temperature Range: -40 ~ +85 °C

Storage Condition before Soldering (Included packaging material)

Storage Temperature Range: +5 ~ +40 °C

Humidity: 30 to 70% relative humidity

Typical Electrical Chart

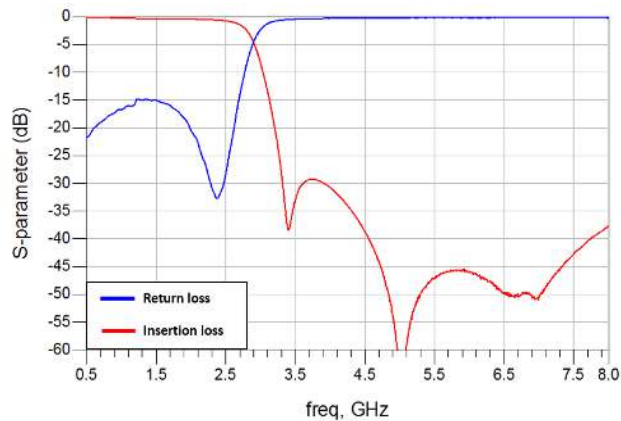

LAND PATTERN

Figure

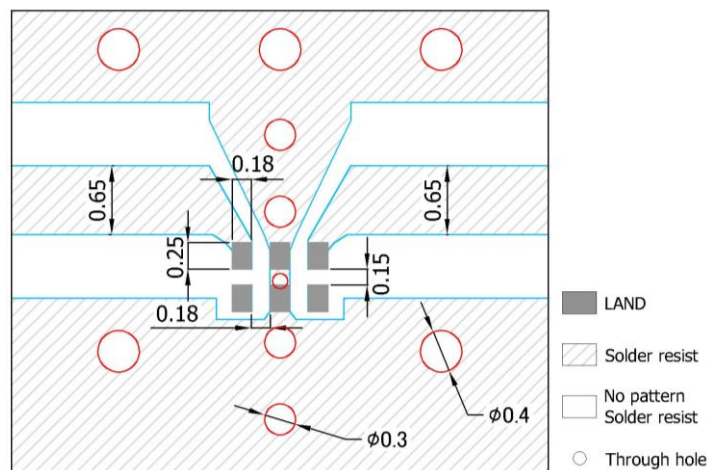

*Don't connect NC pin (pin1 and pin3) to I/O or GND.

Unit : mm

Line width to be designed to match 50 Ω characteristic impedance, depending on PCB material and thickness.

RELIABILITY TEST

Test item	Test condition / Test method	Specification
Solderability JIS C 0050-4.6 JESD22-B102D	*Solder bath temperature : $235 \pm 5^{\circ}\text{C}$ *Immersion time : 2 ± 0.5 sec Solder : Sn3Ag0.5Cu for lead-free	At least 95% of a surface of each terminal electrode must be covered by fresh solder.
Resistance to soldering heat JIS C 0050-5.4	*Preheating temperature : $120\sim 150^{\circ}\text{C}$, 1 minute. *Solder temperature : $270\pm 5^{\circ}\text{C}$ *Immersion time : 10 ± 1 sec Solder : Sn3Ag0.5Cu for lead-free Measurement to be made after keeping at room temperature for 24 ± 2 hrs	No mechanical damage. Electrical specification shall satisfy the descriptions in electrical characteristics under the operational temperature range within $-40\sim 85^{\circ}\text{C}$. Loss of metallization on the edges of each electrode shall not exceed 25%.
Drop Test JIS C 0044 Customer's specification.	*Height : 75 cm *Test Surface : Rigid surface of concrete or steel. *Times : 6 surfaces for each units ; 2 times for each side.	No mechanical damage. Electrical specification shall satisfy the descriptions in electrical characteristics under the operational temperature range within $-40\sim 85^{\circ}\text{C}$.
Vibration JIS C 0040	*Frequency : $10\text{Hz}\sim 55\text{Hz}\sim 10\text{Hz}(1\text{min})$ *Total amplitude : 1.5mm *Test times : 6hrs.(Two hrs each in three mutually perpendicular directions)	No mechanical damage. Electrical specification shall satisfy the descriptions in electrical characteristics under the operational temperature range within $-40\sim 85^{\circ}\text{C}$.
Adhesive Strength of Termination JIS C 0051- 7.4.3	*Pressurizing force : 5N (LGA terminal series) ; $5\text{N}(\leq 0603)$; 10N(>0603) *Test time : 10 ± 1 sec	No remarkable damage or removal of the termination.
Bending test JIS C 0051- 7.4.1	The middle part of substrate shall be pressurized by means of the pressurizing rod at a rate of about 1 mm/s per second until the deflection becomes 1mm/s and then pressure shall be maintained for 5 ± 1 sec. Measurement to be made after keeping at room temperature for 24 ± 2 hours	No mechanical damage. Electrical specification shall satisfy the descriptions in electrical characteristics under the operational temperature range within $-40\sim 85^{\circ}\text{C}$.

Approval sheet

<p>Temperature cycle JIS C 0025</p>	<ol style="list-style-type: none"> 1. 30±3 minutes at -40°C±3°C, 2. 10~15 minutes at room temperature, 3. 30±3 minutes at +85°C±3°C, 4. 10~15 minutes at room temperature, <p>Total 100 continuous cycles</p> <p>Measurement to be made after keeping at room temperature for 24±2 hrs</p>	<p>No mechanical damage.</p> <p>Electrical specification shall satisfy the descriptions in electrical characteristics under the operational temperature range within -40 ~ 85°C.</p>
<p>High temperature JIS C 0021</p>	<p>*Temperature : 85°C±2°C</p> <p>*Test duration : 1000+24/-0 hours</p> <p>Measurement to be made after keeping at room temperature for 24±2 hrs</p>	<p>No mechanical damage.</p> <p>Electrical specification shall satisfy the descriptions in electrical characteristics under the operational temperature range within -40 ~ 85°C.</p>
<p>Humidity (steady conditions) JIS C 0022</p>	<p>*Humidity : 90% to 95% R.H.</p> <p>*Temperature : 40±2°C</p> <p>*Time : 1000+24/-0 hrs.</p> <p>Measurement to be made after keeping at room temperature for 24±2 hrs</p> <p>※ 500hrs measuring the first data then 1000hrs data</p>	<p>No mechanical damage.</p> <p>Electrical specification shall satisfy the descriptions in electrical characteristics under the operational temperature range within -40 ~ 85°C.</p>
<p>Low temperature JIS C 0020</p>	<p>*Temperature : -40°C±2°C</p> <p>*Test duration : 1000+24/-0 hours</p> <p>Measurement to be made after keeping at room temperature for 24±2 hrs</p>	<p>No mechanical damage.</p> <p>Electrical specification shall satisfy the descriptions in electrical characteristics under the operational temperature range within -40 ~ 85°C.</p>

SOLDERING CONDITION

Typical examples of soldering processes that provide reliable joints without any damage are given in Fig 2,

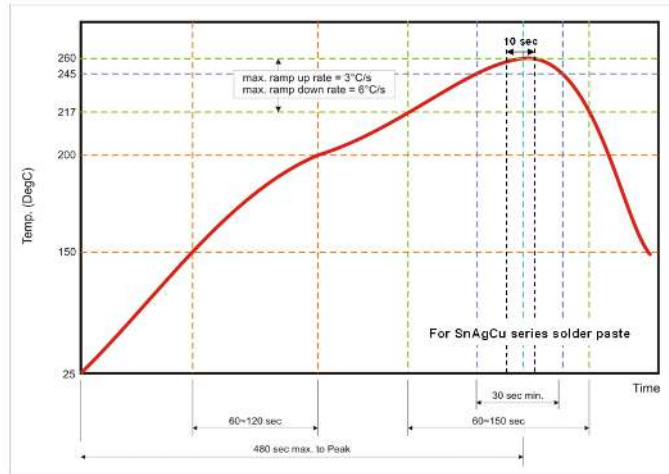

Fig 2. Infrared soldering profile

ORDERING CODE

RF	LPF	100504	0	F	0	T
Walsin RF device	Product Code LPF : Low Pass Filter	Dimension code Per 2 digits of Length, Width e.g:100504: L=1.0mm, W= 0.5mm, T= 0.4mm.	Unit of dimension 0 : 0.1 mm 1 : 1.0 mm	Application F: 1695~2180 MHz	Specification Design Code	Packing T : Reeled

Minimum Ordering Quantity: 4000 pcs per reel.

PACKAGING

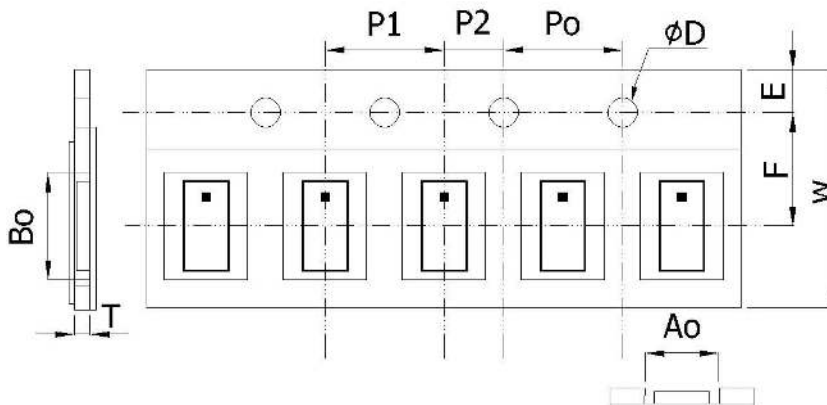

Paper Tape specifications (unit :mm)

Index	Ao	Bo	φD	T	W
Dimension (mm)	0.67 ± 0.10	1.14 ± 0.10	1.55 ± 0.05	0.42 ± 0.10	8.0 ± 0.10
Index	E	F	Po	P1	P2
Dimension (mm)	1.75 ± 0.10	3.50 ± 0.05	4.00 ± 0.10	4.00 ± 0.10	2.00 ± 0.05

Reel dimensions

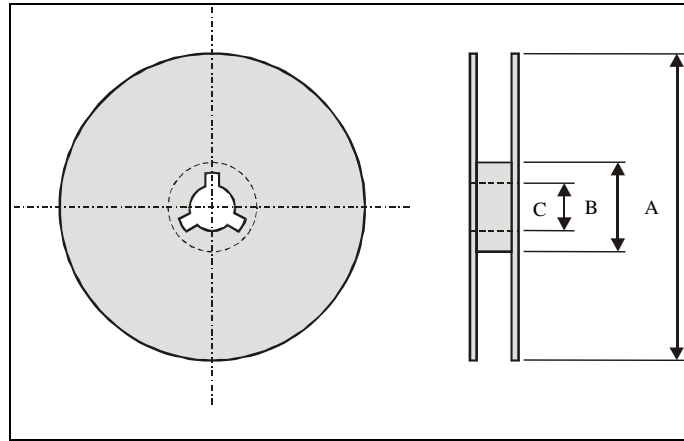

Index	A	B	C
Dimension (mm)	Φ178.0	Φ60.0	Φ13.0

Taping Quantity:4000 pieces per 7" reel

CAUTION OF HANDLING**Limitation of Applications**

Please contact us before using our products for the applications listed below which require especially high reliability for the prevention of defects, which might directly cause damage to the third party's life, body or property.

- (1) Aircraft equipment
- (2) Aerospace equipment
- (3) Undersea equipment
- (4) Medical equipment
- (5) Disaster prevention / crime prevention equipment
- (6) Traffic signal equipment
- (7) Transportation equipment (vehicles, trains, ships, etc.)
- (8) Applications of similar complexity and /or reliability requirements to the applications listed in the above.

Storage condition

- (1) Products should be used in 6 months from the day of WALSIN outgoing inspection.
- (2) Storage environment condition.
 - Products should be storage in the warehouse on the following conditions.
 - Temperature : +5 to +40°C
 - Humidity : 30 to 70% relative humidity
 - Don't keep products in corrosive gases such as sulfur. Chlorine gas or acid or it may cause oxidization of electrode, resulting in poor solderability.
 - Products should be storage on the palette for the prevention of the influence from humidity, dust and son on.
 - Products should be storage in the warehouse without heat shock, vibration, direct sunlight and so on.
 - Products should be storage under the airtight packaged condition.