

ABIDE BY ROHS

■ Specification :

- 1.Rating:
Voltage :12V AC/DC max.,2V DC min.
Current: 10mA AC/DC max.,10μA DC min.
- 2.Contact Resistance : 100mΩ Max
- 3.Insulation Resistance :100MΩ min (500V)
- 4.Withstand Voltage : AC100V(50-60Hz)
for 1 minute
- 5.Contact:All the Surface plating Ni,then gold plating for contact Area, Tin plating for welding area
- 6.Mating Force :3.0kgf max
- 7.Mechanical Life :100 Cycles

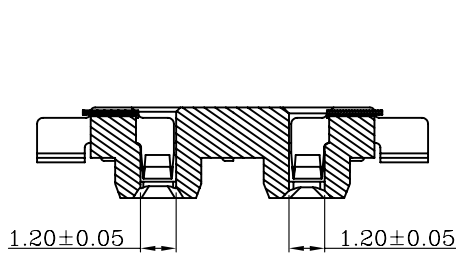
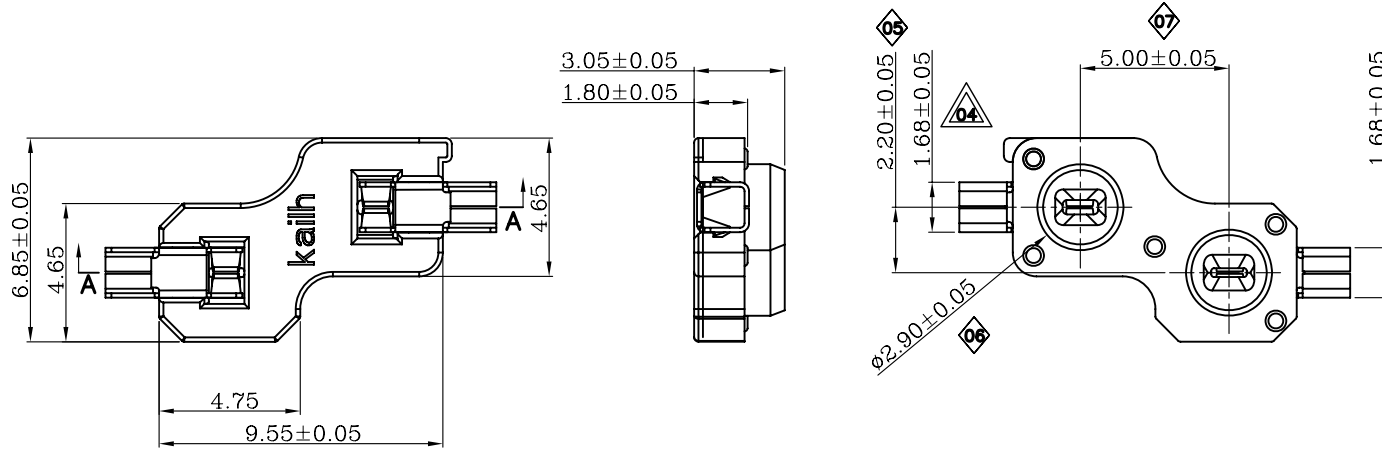
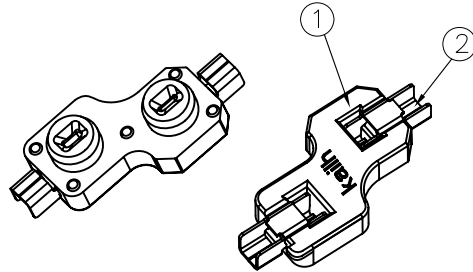
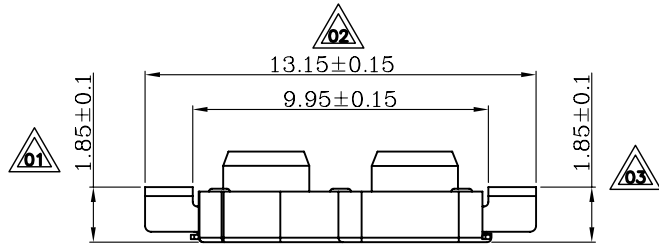

SECTION A-A

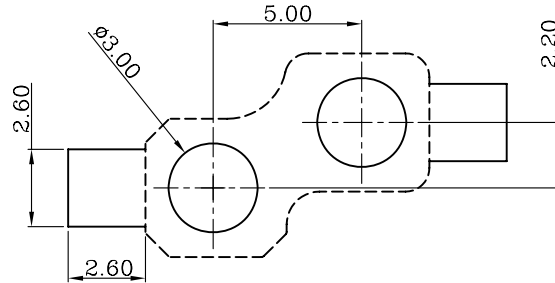

PCB LAYOUT

② contact	2	Copper Alloy				
① Base	1	Nylon	Black			
ITEM	PART NAME	TER'NO	QTY.	MATERIAL	FINISHING	REMARK

APPROVALS		DATE	DONGGUAN CITY KAIHUA ELECTRONICS CO.,LTD Kaih		
DRAWN	huyuanfeng	2017-01-26			

CHECKED		TITLE:	PG1350 KeySwitches Contact		
APPROVALS		PART NO.	CPG135001S30		

TOLERANCES ARE	30<L	±0.30	ANGLE	UNIT: mm	SCALE: 1:1	PROJ:
	10<L≤30	±0.20				
	5<L≤10	±0.15				
	L≤5	±0.10	±2'	DRAWING NO.	KHA-PG1350-005EN	SHEET 1 OF 1

ECN NO.	REV.	DATE.	DESCRIPTION.	CHANGE.	CHECK.	APPRO.
	A		NEW			



凱華電子
KAIHUA EEELETRONICS

Document Number:

KH-PS-1702-35

产品规格书

Product Specification

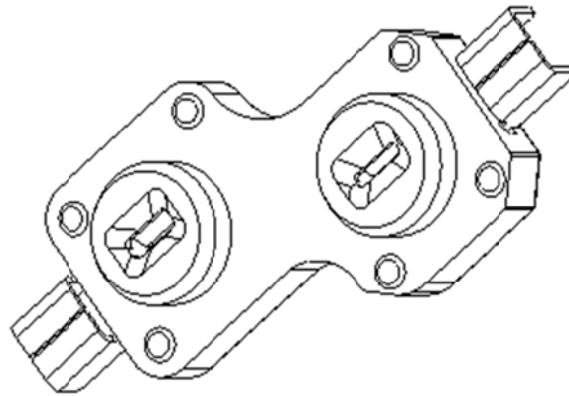

P/N: _____

CPG135001S30

Title :

1350 Connector

Rev.	ECN	Release and Revision Description:	Prepared By /Date:	Checked By/Date:	Approved By/Date:
A	_____	New releasing 初版发行			



P/N: CPG135001S30	DOC. No.: KH-PS-1702-35	Rev.: A	Page: 2/10
----------------------	----------------------------	------------	---------------

Content

目录

1. Scope/范围:.....	3
2. Product Application/产品应用 :	3
3. Technology Parameters/技术参数	3
4. Ratings/额定性能要求.....	3
5. Profile Dimensions /外形尺寸	4
6. Electrical Performance/电气性能	5
7. Mechanical Performance/机械性能.....	6
8. Environmental Performance/环境性能.....	7
9. Recommended PCB Layout/推荐的 PCB 安装焊盘规格	8
10. Packaging/包装.....	8
11. Precaution/注意事项	9



P/N: CPG135001S30	DOC. No.: KH-PS-1702-35	Rev.: A	Page: 3/10
-----------------------------	-----------------------------------	-------------------	----------------------

1. Scope/范围:

This Product Specification covers the requirement of Mechanical keyboard Connector switch on product performance, test methods and quality assurance provisions.
本规格书内容涵盖机械键盘连接器产品的要求，包括性能指标、测试方法及质量保证方面等。

2. Product Application/产品应用:

Mainly applied on computer keyboards,cash registers equipment and Man-Machine interface.

主要适用于电脑，收银机，工业设备和人机界面

3. Technology Parameters/技术参数

Ambient Humidity 工作湿度:	45~95% R.H.;
Operating Temperature Range 使用温度范围:	-10℃~+60℃;
Storage Temperature Range 保存温度范围:	-20℃~+70℃;
Normal Condition:	
Ambient temperature 环境温度:	20±2℃
Relative humidity 相对湿度:	85%±5% R.H.;
Air pressure 气压:	86~101KPa;
Contact Resistance 接触阻抗:	100 mΩ Max;
Solder Ability 可焊性:	260±5℃,3±0.5s;
Withstand Soldering Temperature 耐焊接热:	260±5℃,5±1s;

4. Ratings/额定性能要求

Rating Voltare 额定电压:	12V AC/DC max; 2V DC min
Rating Current 额定电流	10mA AC/DC max; 10uA DC min
InsulationResistance 绝缘电阻:	≥100MΩ/DC 500V;
Withstand Voltage 耐电压:	AC 100V 1 Minute;
Mechanical Life 机械寿命:	100Cycles .
Profile Dimensions /外形尺寸	

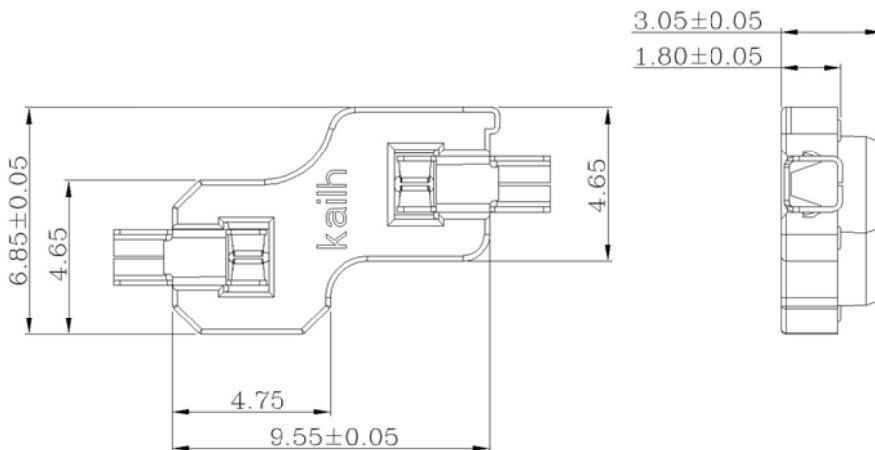



5. Electrical Performance/电气性能

Item 项目	Description 项目描述	Test Condition 测试条件	Requirement 规格要求
6.1	Contact Resistance 接触电阻	Static load: (Operation force)x2, which is applied on the center of Switch stem. 静态负载: 动作力的 2 倍, 施加在手柄中心. Measurement tool: Contact resistance Meter. 测量工具: 微电流接触电阻计(1KHz, 20mV,5~50mA)	100mΩ Max 100mΩ 以下
6.2	Insulation Resistance 绝缘电阻	Apply a Voltage of DC 500 V for 1 minute, according to the below method. (1) Between terminals. (2) Between terminal and Body. 输入 500V DC 电压 1 分钟, 按如下接触方法测试: (1) 端子与端子之间. (2) 端子与外壳之间.	100MΩ Min 100 兆欧以上
6.3	Dielectric withstanding voltage 耐电压	Apply a Voltage of AC 100 V (50~60Hz) for 1 minute, according to the below method. (1) Between terminals. (2) Between terminal and Body. 输入 100V AC 电压 1 分钟, 按如下接触方法测试: (1) 端子与端子之间. (2) 端子与外壳之间.	No evidence of breakdown 无瞬断、击穿等破坏.

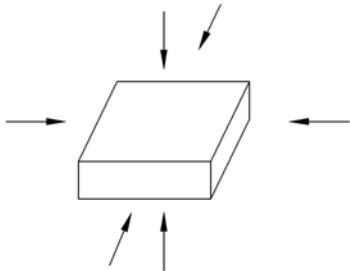

6. Mechanical Performance/机械性能

Item 项目	Description 项目描述	Test Condition 测试条件	Requirement 规格要求
7.1	Mating force 插入力	At 16in/minute.actuation speed	Mating force 插入力 3KG max
7.2	Unmating force 拔出力	At 16in/minute.actuation speed	Unmating force 拔出力 200gf min
7.3	Shock 机械冲击	<p>Measured by according to the below condition: (1) Acceleration: 80g 加速度 (2) Cycles of test:3 cycles each in 6 directions, for a total of 18 cycles. 试验次数: 每个方向 3 次, 6 个方向共 18 次.</p> 	Appearance: No abnormality. 外观无异常
7.4	Life Test 寿命测试	<p>(1) without load 无负载 (2) Mating force: Maximum value of operation force. 插入力: 操作力规格值的上限. (3) Cycles: 100 Min 操作次数: 100 次以上</p>	<p>Contact resistance: 1000 mΩ Max 接触电阻: 1000 毫欧以下 Bouncing: 10ms Max</p>



7. Environmental Performance/环境性能

Item 项目	Description 项目描述	Test Condition 测试条件	Requirement 规格要求												
8.1	Cold test 耐寒性	(1) Temperature : - 20±2℃ 温度: - 20±2℃ (2) Duration of test: 48h 持续时间: 48 小时 (3) Take off a drop water 去掉水珠 (4) Standard conditions after test : 1h 试验后的放置条件: 1 小时	Contact resistance: 200mΩ Max 接触电阻 200mΩ 以下												
8.2	Heat test 耐热性	(1) Temperature : 70±2℃ 温度: 70±2℃ (2) Duration of test: 48h 持续时间: 48 小时 (3) Take off a drop water 去掉水珠 (4) Standard conditions after test : 1h 试验后的放置条件: 1 小时	Contact resistance: 200mΩ Max Shall meet : No. 6.2 接触电阻 200mΩ 以下 满足: No. 6.2												
8.3	Temperature cycle 温度循环	(1) Test cycles:20 cycles 试验周期: 5 个周期 (2) Standard condition after test:1h 试验后的放置条件: 1 小时 <table border="1" data-bbox="432 1346 987 1536"> <thead> <tr> <th></th> <th>Temperature 温度</th> <th>Duration of test 持续时间</th> </tr> </thead> <tbody> <tr> <td rowspan="4">1 cycle 一次循环</td> <td>20±5℃</td> <td>1h</td> </tr> <tr> <td>-20±5℃</td> <td>1h</td> </tr> <tr> <td>20±5℃</td> <td>1h</td> </tr> <tr> <td>70±5℃</td> <td>1h</td> </tr> </tbody> </table>		Temperature 温度	Duration of test 持续时间	1 cycle 一次循环	20±5℃	1h	-20±5℃	1h	20±5℃	1h	70±5℃	1h	Contact resistance: 200mΩ Max Shall meet : No. 6.2 接触电阻 200mΩ 以下 满足: No. 6.2
	Temperature 温度	Duration of test 持续时间													
1 cycle 一次循环	20±5℃	1h													
	-20±5℃	1h													
	20±5℃	1h													
	70±5℃	1h													
8.4	Soldering heat test 耐焊接热	Soldering area: T/2 of PWB thickness. (PWB: T=1.6mm) 焊接面积: 印刷基板的 1/2 厚度处 Soldering temperature: 260±5℃ Soldering time: 5±0.5s 焊接温度: 260±5℃ 焊接时间: 5±0.5 秒	Appearance: No abnormality. 外观无异常												



8.5

Solderability
可焊性

- Hand soldering 手工焊接:
Please practice according to below condition:
(1) Soldering Temperature : $350 \pm 5^{\circ}\text{C}$
焊接温度: $350 \pm 5^{\circ}\text{C}$
(2) Continual soldering time: $3 \pm 0.5\text{s}$
连续焊接时间: 3 ± 0.5 秒
(3) Capacity of soldering iron: $\leq 20\text{w}$
电烙铁功率: 20 瓦以下
- Automatic Reflow soldering 自动回流焊接:
For the product of SMT, according to below condition:

SMT 回流焊温度曲线图

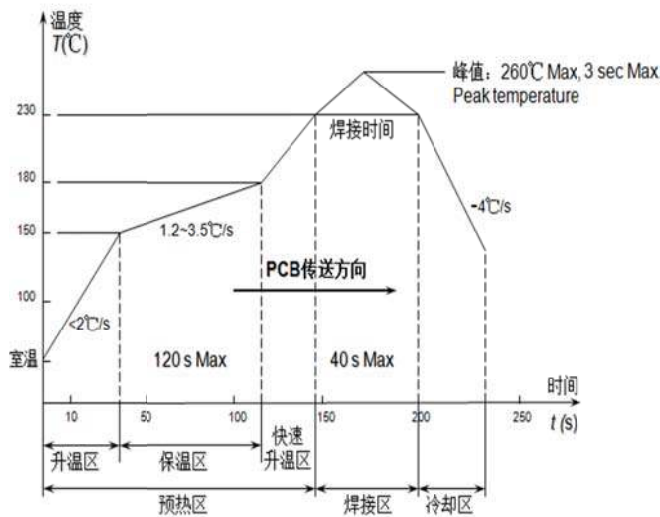

At least 95% of surface area of immersed portion shall be covered by solder.
侵焊面积大于 95%以上。

8.6

Humidity test
耐湿性

- Temperature : $60 \pm 2^{\circ}\text{C}$
温度: $60 \pm 2^{\circ}\text{C}$
- relative humidity: 90~95% R.H.
相对湿度: 90~95% R.H.
- Duration of test: 48h
持续时间: 48 小时
- Take off a drop water
去掉水珠
- Standard conditions after test: 1h
试验后的放置条件: 1 小

Contact resistance:
 $200\text{m}\Omega$ Max
Shall meet :
No. 6.2
接触电阻 $200\text{m}\Omega$ 以下
满足:
No. 6.2



P/N: CPG135001S30	DOC. No.: KH-PS-1702-35	Rev.: A	Page: 8/10
-----------------------------	-----------------------------------	-------------------	----------------------

8.7	Salt Spray 盐雾测试	<p>Apply the following environment to test: 根据下列条件进行测试:</p> <p>(1) Temperature : 35±5°C 温度: 35±5°C;</p> <p>(2) Salt water density: 5±1% 盐水浓度: 5±1%;</p> <p>(3) Duration: 12 hours 持续时间: 12 小时;</p> <p>(4) After test, the salt deposit shall be removed by running water. 实验后将盐沉积物用水冲掉</p>	<p>Appearance: No corrosion spot, no crack, no base plate naked. 外观: 无腐蚀点, 无裂纹, 无裸露基材.</p> <p>Contact Resistance: 200 mΩ Max 接触电阻: 200 毫欧以下</p>
8.8	Withstand K ₂ S 硫化测试	<p>Apply the following environment to test: 根据下列条件进行测试</p> <p>(1) Temperature: 35±5°C 温度: 35±5°C</p> <p>(2) K₂S Density: 2%; 硫化钾浓度: 2%</p> <p>(3) Duration: 2 minute. 持续时间: 2 分钟</p>	<p>Appearance: No corrosion spot, no crack, no base plate naked. 外观: 无腐蚀点, 无裂纹, 无裸露基材.</p> <p>Contact Resistance: 1000 mΩ Max 接触电阻: 1000 毫欧以下</p>

8. Recommended PCB Layout 推荐的 PCB 安装焊盘规格

(Top View)
(Single face board T=1.6mm)

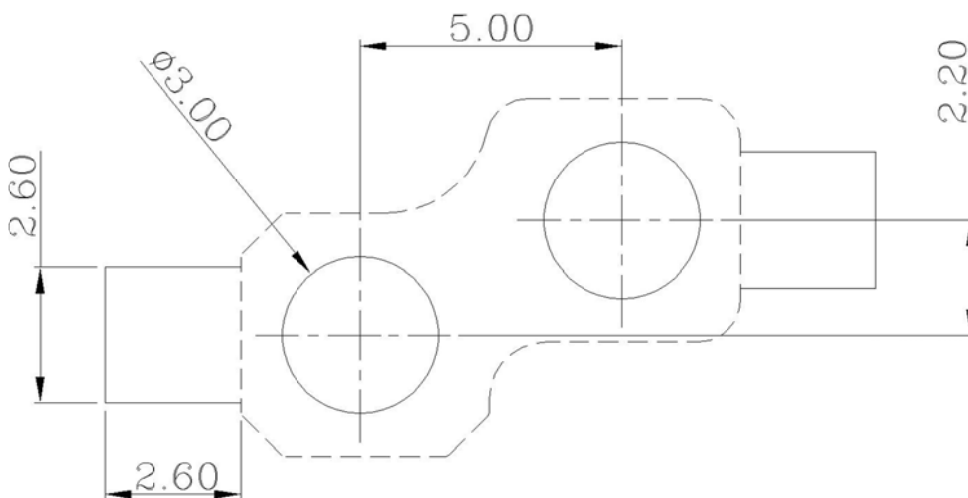



10. Packaging 包装

Packaging type: 13Tray, 26000Pcs/Carton.

包装方式:13 /盘, 26000Pcs/箱.



11.Precaution 注意事项

11.1 Soldering condition 回流焊条件

ITEM 项目	CONDITION 条件	
Preheating zone 预热区	Heating zone 升温区	Speed < 2°C/S, Preheating time 15 S Max, temperature 150°C 速度 < 2°C/S, 预热时间 15 S 最多, 温度 150°C
	Heatpreservati on area 保温区	Speed 1.2~3.5°C/S, Preheating time 120 S Max, temperature 180°C 速度 1.2~3.5°C/S, 预热时间 120 S 最多, 温度 180°C
	Fast heating zone 快速升温区	Speed 3.5~4.5°C/S, Preheating time 140 S Max, temperature 230°C 速度 3.5~4.5°C/S, 预热时间 140 S 最多, 温度 230°C
Weld area 焊接区	Welding time 40 S Max, welding temperature peak value, 3 sec Max. 焊接时间 40 S 最多, 焊接温度峰值 260°C 最大, 3 S 最多	
Area of flux 助焊剂面积	1/2 Max of PWB Thickness 印刷基板厚度的 1/2 以内	
Temperature of solder 焊锡温度	260 ± 5°C 260 ± 5°C	
Number of soldering 焊接次数	2 time Max (But should down heat of the first soldering) 2 次以内	
Printed wiring board 印刷基板	Single side copper-clad laminates 单面铜箔	

- (1) After reflow, be careful not to clean switches with solvent
回流焊后, 注意不要用溶剂清洗.
- (2) Under the condition of using soldering iron, soldering temperature shall be 350°C max within 3 sec.
在使用烙铁的情况下, 焊锡温度应在 350°C 以下, 焊接时间 3 秒以内.



P/N: CPG135001S30	DOC. No.: KH-PS-1702-35	Rev.: A	Page: 10/10
----------------------	----------------------------	------------	----------------

11.2 Notes 注意点

- (1) Please be cautious not to give excessive static load connector.
注意不要施加超负荷的压力或晃动连接器.
- (2) Connector be careful not to stack up P. W. B. after switches were soldered.
连接器焊接以后,印刷基板注意不要叠放.
- (3) Preservation under high temperature and high humidity or corrosive gas should be avoided
Especially. When you need to preserve for a long period, do not open the carton.
保管时尤其应注意避开高湿高温和有腐蚀性气体的环境.如需长时间保存,请不要打开包装箱.
- (4) Products meet the ROHS & REACH environmental management substances control standards
产品满足 ROHS & REACH 环境管理物质管制标准