

REV	ECN	APP'D
A	6689	<i>[Signature]</i>

NOTES:

- MATERIALS AND FINISH
 TRACK, LOCKING CLAMP, AND END STOP - ALUMINUM ALLOY 6063
 TEMPER T5, PER FED SPEC. QQ-A-200/9, BLACK ANODIZE PER MIL-A-8625
 TYPE II, CLASS 2.
 LOCKING CLAMP SCREW - CORROSION RESISTANT, PASSIVATED, SELF-LOCKING.
 RIVETS - ALUMINUM ALLOY #2117, CHROMATE PER MIL-DTL-5541, CLASS 1A, YELLOW.
- APCD P/N TJT701003 (M81714/5-2) SHOWN.

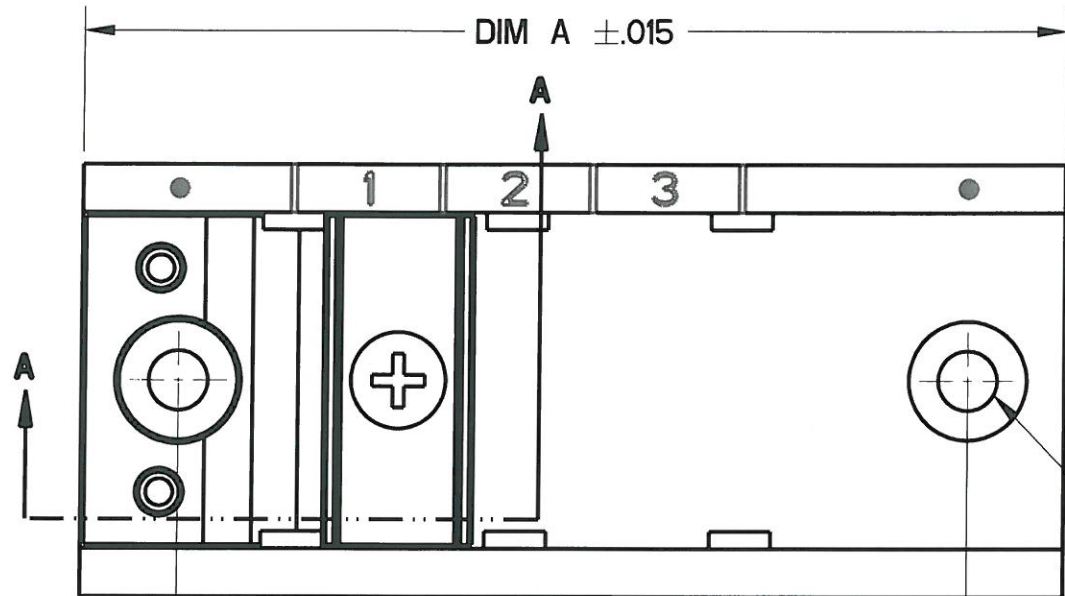

Ø.154 MOUNTING HOLES
 CSK 82° X .307 DIA
 4X

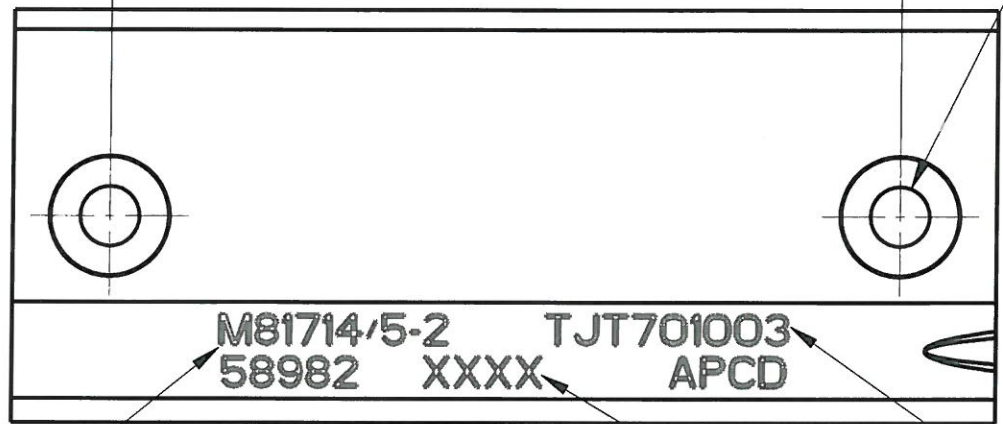
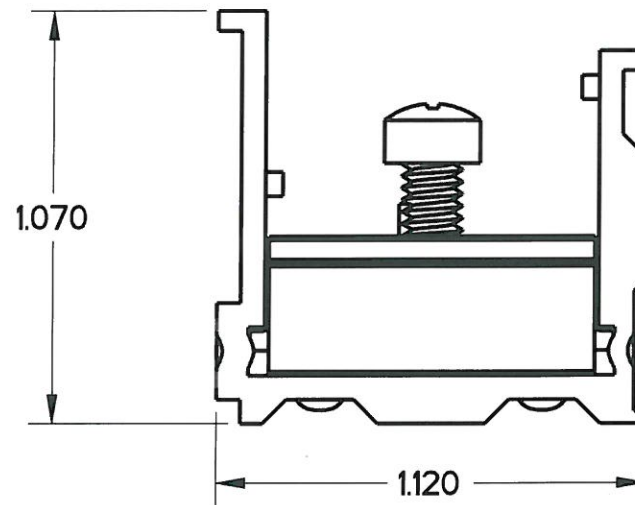

MIL P/N → M81714/5-2 58982
 DATE CODE → XXXX
 APCD P/N → TJT701003 APCD

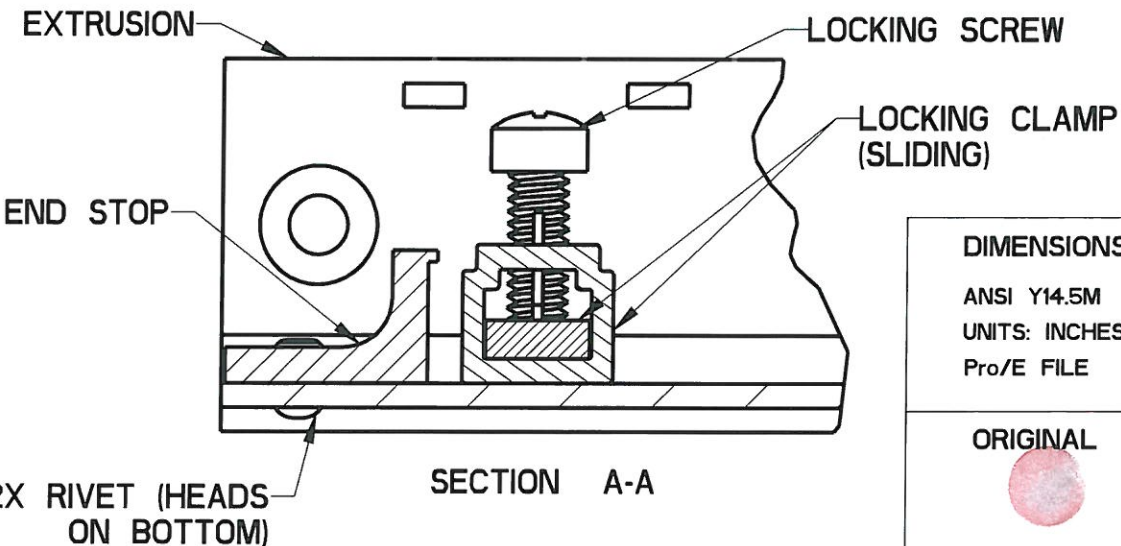

* DIVIDE BY 3 FOR SIZE 12 MODULE MOUNTING

MIL P/N	APCD P/N	MTG POS.	DIM A	DIM L
M81714/5-1	TJT701010	10	5.291	4.791
M81714/5-2	TJT701003	3	2.561	2.061
M81714/5-3	TJT701004	4	2.951	2.451
M81714/5-4	TJT701005	5	3.341	2.841
M81714/5-5	TJT701006	6	3.731	3.231
M81714/5-6	TJT701007	7	4.121	3.621
M81714/5-7	TJT701008	8	4.511	4.011
M81714/5-8	TJT701009	9	4.901	4.401
M81714/5-9	TJT701011	11	5.681	5.181
M81714/5-10	TJT701012	12	6.071	5.571
M81714/5-11	TJT701013	13	6.461	5.961
M81714/5-12	TJT701014	14	6.851	6.351
M81714/5-13	TJT701015	15	7.241	6.741

DIMENSIONS ANSI Y14.5M UNITS: INCHES Pro/E FILE	TOLERANCES .XX ±0.01 .XXX ±0.005 ANGLES ±2.0°	PROJECTION 	Amphenol Pcd SPECIFICATION DRAWING ENGR M. Hai 12-Apr-11	
			ORIGINAL THIS DOCUMENT CONTAINS PROPRIETARY INFORMATION WHICH IS THE CONFIDENTIAL PROPERTY OF AMPHENOL PCD INC. BEVERLY, MA, USA CHKD <i>[Signature]</i> 4/19/11 APPD <i>[Signature]</i> 4/20/11	

TITLE TERMINAL JUNCTION TRACK FEEDBACK - STANDARD M81714/5, SERIES I			
SIZE	DWG NO.	REV	
B	TJT701003	A	
CODE: 58982	SCALE: 2:1	SHEET 1 OF 1	

TJT701003

TJT701003