



Is Now Part of



ON Semiconductor®

To learn more about ON Semiconductor, please visit our website at
www.onsemi.com

Please note: As part of the Fairchild Semiconductor integration, some of the Fairchild orderable part numbers will need to change in order to meet ON Semiconductor's system requirements. Since the ON Semiconductor product management systems do not have the ability to manage part nomenclature that utilizes an underscore (_), the underscore (_) in the Fairchild part numbers will be changed to a dash (-). This document may contain device numbers with an underscore (_). Please check the ON Semiconductor website to verify the updated device numbers. The most current and up-to-date ordering information can be found at www.onsemi.com. Please email any questions regarding the system integration to Fairchild_questions@onsemi.com.

ON Semiconductor and the ON Semiconductor logo are trademarks of Semiconductor Components Industries, LLC dba ON Semiconductor or its subsidiaries in the United States and/or other countries. ON Semiconductor owns the rights to a number of patents, trademarks, copyrights, trade secrets, and other intellectual property. A listing of ON Semiconductor's product/patent coverage may be accessed at www.onsemi.com/site/pdf/Patent-Marking.pdf. ON Semiconductor reserves the right to make changes without further notice to any products herein. ON Semiconductor makes no warranty, representation or guarantee regarding the suitability of its products for any particular purpose, nor does ON Semiconductor assume any liability arising out of the application or use of any product or circuit, and specifically disclaims any and all liability, including without limitation special, consequential or incidental damages. Buyer is responsible for its products and applications using ON Semiconductor products, including compliance with all laws, regulations and safety requirements or standards, regardless of any support or applications information provided by ON Semiconductor. "Typical" parameters which may be provided in ON Semiconductor data sheets and/or specifications can and do vary in different applications and actual performance may vary over time. All operating parameters, including "Typicals" must be validated for each customer application by customer's technical experts. ON Semiconductor does not convey any license under its patent rights nor the rights of others. ON Semiconductor products are not designed, intended, or authorized for use as a critical component in life support systems or any FDA Class 3 medical devices or medical devices with a same or similar classification in a foreign jurisdiction or any devices intended for implantation in the human body. Should Buyer purchase or use ON Semiconductor products for any such unintended or unauthorized application, Buyer shall indemnify and hold ON Semiconductor and its officers, employees, subsidiaries, affiliates, and distributors harmless against all claims, costs, damages, and expenses, and reasonable attorney fees arising out of, directly or indirectly, any claim of personal injury or death associated with such unintended or unauthorized use, even if such claim alleges that ON Semiconductor was negligent regarding the design or manufacture of the part. ON Semiconductor is an Equal Opportunity/Affirmative Action Employer. This literature is subject to all applicable copyright laws and is not for resale in any manner.



FSA1156, FSA1157 Low- R_{ON} , Low-Voltage SPST Analog Switch

Features

- Maximum 0.95Ω R_{ON} for 4.5V Supply at 25°C
- 0.3Ω Maximum R_{ON} Flatness at 4.5V Supply
- Broad V_{CC} Operating Range: 1.65V to 5.5v
- Fast Turn-On and Turn-Off Time
- Over-Voltage Tolerant, TTL-Compatible Control Input
- Available in space-saving 6-lead, MicroPak™ and SC70 Packages

Description

The FSA1156 and FSA1157 are high-performance Single-Pole / Single-Throw (SPST) analog switches. The devices feature ultra-low R_{ON} of 0.75Ω (typical) and operate over a wide V_{CC} range of 1.65 V to 5.5 V. The devices are fabricated with sub-micron CMOS technology to achieve fast switching speeds. The select input is TTL-level compatible. The FSA1156 has normally open operation; the FSA1157 has normally closed operation.

Ordering Information

Part Number	Top Mark	Package Description	Packing Method
FSA1156P6X	156	6-Lead SC70, EIAJ SC88, 1.25mm Wide	3000 Units Tape and Reel
FSA1156L6X	EH	6-Lead MicroPak™, 1.0mm Wide	5000 Units Tape and Reel
FSA1157P6X	157	6-Lead SC70, EIAJ SC88, 1.25mm Wide	3000 Units Tape and Reel
FSA1157L6X	EJ	6-Lead MicroPak™, 1.0mm Wide	5000 Units Tape and Reel

Pin Configurations

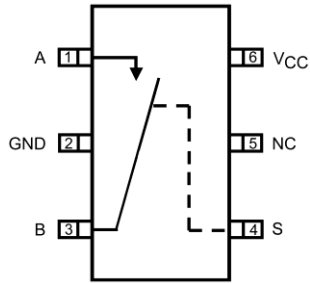

Figure 1. FSA1156 SC70 Top View (Normally Open)

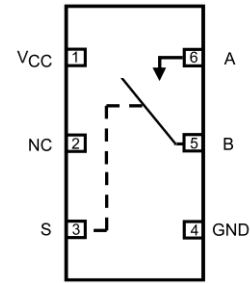

Figure 2. FSA1156 MicroPak™ Top Through View (Normally Open)

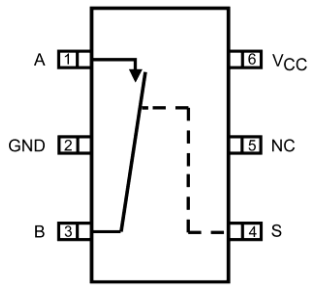

Figure 3. FSA1157 SC70 Top View (Normally Closed)

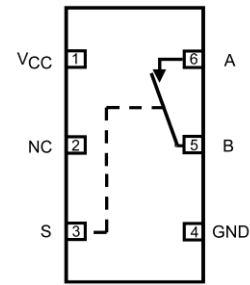

Figure 4. FSA1157 MicroPak™ Top Through View (Normally Closed)

Pin Definitions

Pin# SC70	Pin# Micropak™	Name	Description
1	6	A	Data Ports
2	4	GND	Ground
3	5	B	Data Ports
4	3	S	Control Input
5	2	NC	No Connect
6	1	VCC	Supply Voltage

Truth Table

Control Input (S)	FSA1156	FSA1157
Low	OFF	ON
High	ON	OFF

Absolute Maximum Ratings

Stresses exceeding the absolute maximum ratings may damage the device. The device may not function or be operable above the recommended operating conditions and stressing the parts to these levels is not recommended. In addition, extended exposure to stresses above the recommended operating conditions may affect device reliability. The absolute maximum ratings are stress ratings only.

Symbol	Parameter	Min.	Max.	Unit
V _{CC}	Supply Voltage	-0.5	6.0	V
V _{SW}	Switch Voltage ⁽¹⁾	-0.5	V _{CC} + 0.5	V
V _{IN}	Input Voltage ⁽¹⁾	-0.5	6.0	V
I _{IK}	Input Diode Current		-50	mA
I _{SW}	Switch Current		200	mA
I _{SWPEAK}	Peak Switch Current (Pulse at 1ms Duration, <10% Duty Cycle)		400	mA
P _D	Power Dissipation at 85°C, SC70 Package		180	mW
T _{STG}	Storage Temperature Range	-65	+150	°C
T _J	Maximum Junction Temperature		+150	°C
T _L	Lead Temperature (Soldering, 10 seconds)		+260	°C
ESD	Electrostatic Discharge Capability	Human Body Model, JESD22-A114		8000 V

Note:

1. Input and output negative ratings may be exceeded if input and output diode current ratings are observed.

Recommended Operating Conditions

The Recommended Operating Conditions table defines the conditions for actual device operation. Recommended operating conditions are specified to ensure optimal performance to the datasheet specifications. Fairchild does not recommend exceeding them or designing to Absolute Maximum Ratings.

Symbol	Parameter	Min.	Max.	Unit
V _{CC}	Supply Voltage	1.65	5.50	V
V _{CNTRL}	Control Input Voltage ⁽²⁾	0	V _{CC}	V
V _{SW}	Switch Input Voltage	0	V _{CC}	V
T _A	Operating Temperature	-40	+85	°C
θ _{JA}	Thermal Resistance in Still Air, SC70 Package		350	°C/W

Note:

2. Control input must be held HIGH or LOW and it must not float.

DC Electrical Characteristics

Typical values are at 25°C unless otherwise specified.

Symbol	Parameter	Conditions	V _{CC} (V)	Ambient Temperature (T _A)					Units
				+25°C			-40 to +85°C		
				Min.	Typ.	Max.	Min.	Max.	
V _{IH}	Input Voltage High		2.7 to 3.6				2.0		V
			4.5 to 5.5				2.4		
V _{IL}	Input Voltage Low		2.7 to 3.6					0.6	V
			4.5 to 5.5					0.8	
I _{IN}	Control Input Leakage	V _{IN} =0 V to V _{CC}	2.7 to 3.6				-1.0	1.0	μA
			4.5 to 5.5				-1.0	1.0	
I _{NO(OFF)} , I _{NC(OFF)}	Off Leakage Current	A=1 V, 4.5 V, B=4.5 V, 1 V	5.5	-2		2	20	20	nA
I _{A(ON)}	On Leakage Current	A=1 V, 4.5 V, B=1 V, 4.5 V, or Floating	5.5	-4		4	-40	40	nA
R _{ON}	Switch On Resistance ⁽³⁾	I _{OUT} =100 mA, B=1.5 V	2.7		1.4	2.1		2.5	Ω
		I _{OUT} =100 mA, B=3.5 V	4.5		0.75	0.90		1.00	
R _{FLAT(ON)}	On Resistance Flatness ⁽⁴⁾	I _{OUT} =100 mA, B ₀ =0 V, 0.75 V, 1.5 V	2.7		0.6				Ω
		I _{OUT} =100 mA, B ₀ =0 V, 1 V, 2 V	4.5		0.1	0.2		0.3	
I _{CC}	Quiescent Supply Current	V _{IN} =0 V or V _{CC} , I _{OUT} =0 V	3.6		0.1	0.5		1.0	μA
			5.5		0.1	0.5		1.0	

Notes:

- On resistance is determined by the voltage drop between the A and B pins at the indicated current through the switch.
- Flatness is defined as the difference between the maximum and minimum value of on resistance over the specified range of conditions.

AC Electrical Characteristics

Typical values are at 25°C unless otherwise specified.

Symbol	Parameter	Conditions	V _{CC} (V)	Ambient Temperature (T _A)					Units	Figure
				+25°C			-40 to +85°C			
				Min.	Typ.	Max.	Min.	Max.		
t _{ON}	Turn-On Time	B = 1.5 V, R _L =50 Ω, C _L =35 pF	2.7 to 3.6		30	40		45	ns	Figure 7
		B = 3.0 V, R _L =50 Ω, C _L =35 pF	4.5 to 5.5		15	20		25		
t _{OFF}	Turn-Off Time	B = 1.5 V, R _L =50 Ω, C _L =35 pF	2.7 to 3.6		25	35		45	ns	Figure 7
		B = 3.0 V, R _L =50 Ω, C _L =35 pF	4.5 to 5.5		22	30		40		
Q	Charge Injection	C _L =1.0 nF, V _{GE} =0 V, R _{GEN} =0Ω	2.7 to 3.6		10				pC	Figure 8
			4.5 to 5.5		20					
OIRR	Off Isolation	f=1 MHz, R _L =50 Ω	2.7 to 3.6		-65				dB	Figure 9
			4.5 to 5.5		-65					
BW	-3db Bandwidth	R _L =50 Ω	2.7 to 3.6		300				MHz	Figure 10
			4.5 to 5.5		300					
THD	Total Harmon Distortion	R _L =600 Ω, V _{IN} =0.5 V _{PP} , f=20 Hz to 20 kHz	2.7 to 3.6		0.001				%	Figure 11
			4.5 to 5.5		0.001					

Capacitance

Symbol	Parameter	Conditions	V _{CC} (V)	Ambient Temperature +25°			Units	Figure
				Min.	Typ.	Max.		
C _{IN}	Control Pin Input Capacitance	f=1 MHz	0.0		3		pF	Figure 12
C _{OFF}	B Port Off Capacitance	f=1 MHz	4.5		20		pF	Figure 12
C _{ON}	On Capacitance	f=1 MHz	4.5		65		pF	Figure 12

Typical Performance Characteristics

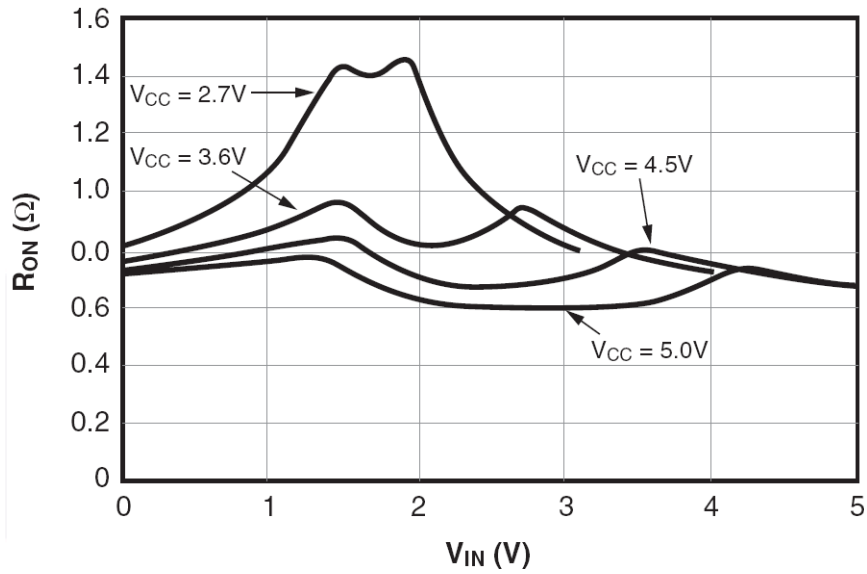

Figure 5. On Resistance vs. Input Voltage, Over Supply Voltage, $T_A=25^\circ C$

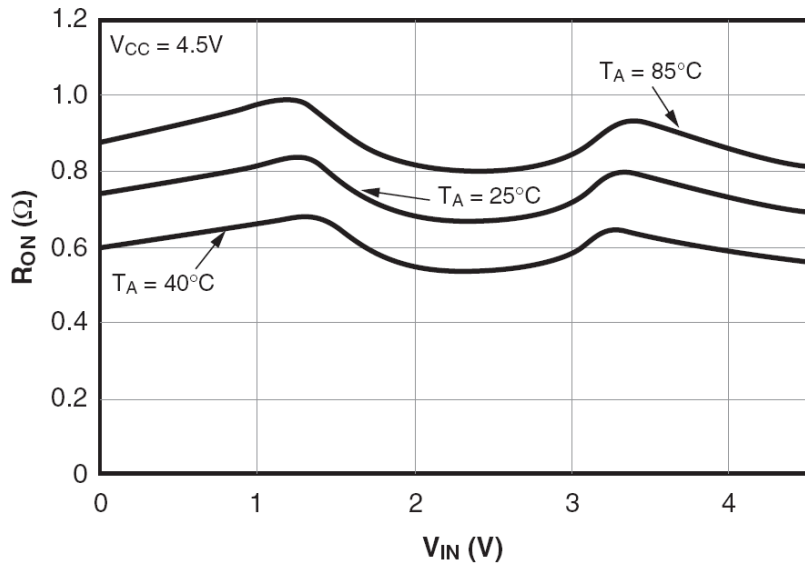
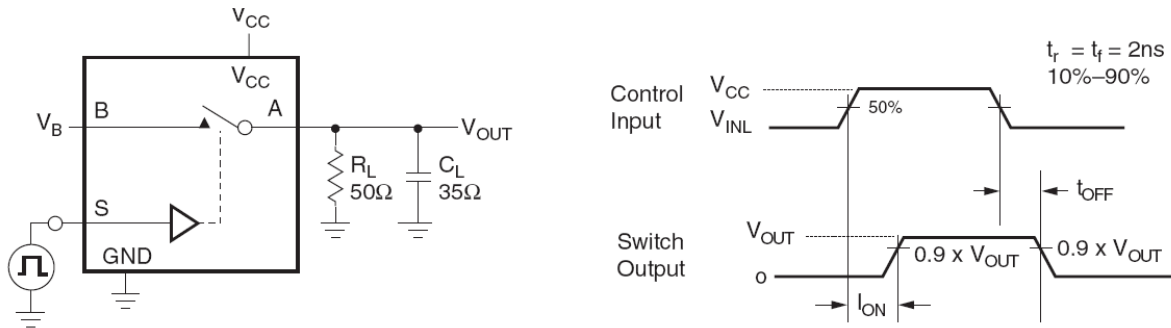

Figure 6. On Resistance vs. Input Voltage, Over Temperature

AC Loadings and Waveforms



C_L Includes Fixture and Stray Capacitance

Logic Input Waveforms Inverted for Switches that have the Opposite Logic Sense

Figure 7. Turn On / Off Timing

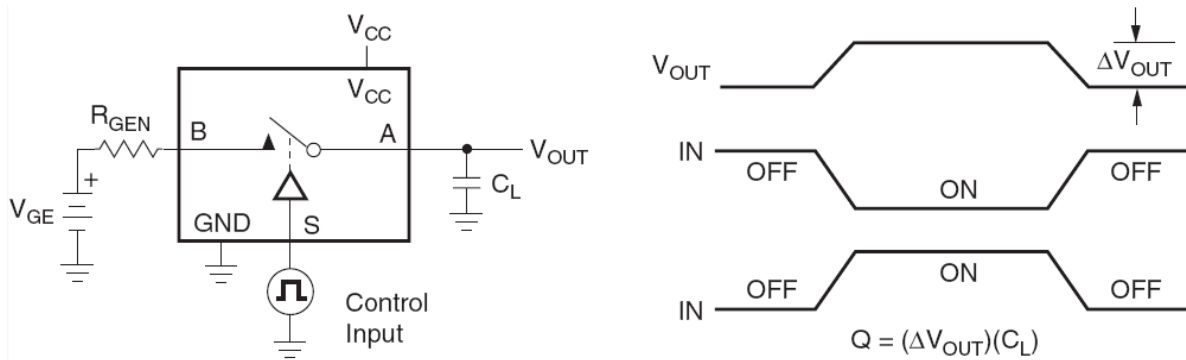

Figure 8. Charge Injection

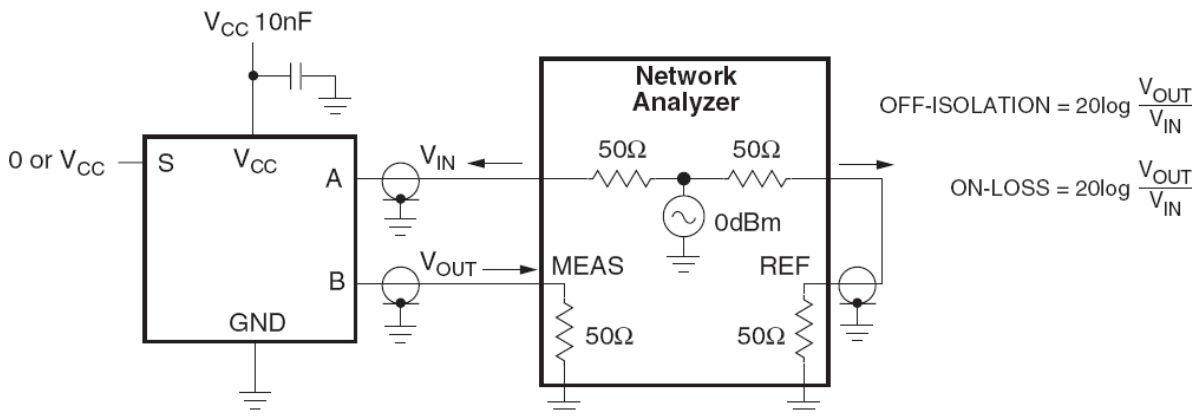

Figure 9. Off Isolation

AC Loadings and Waveforms (Continued)

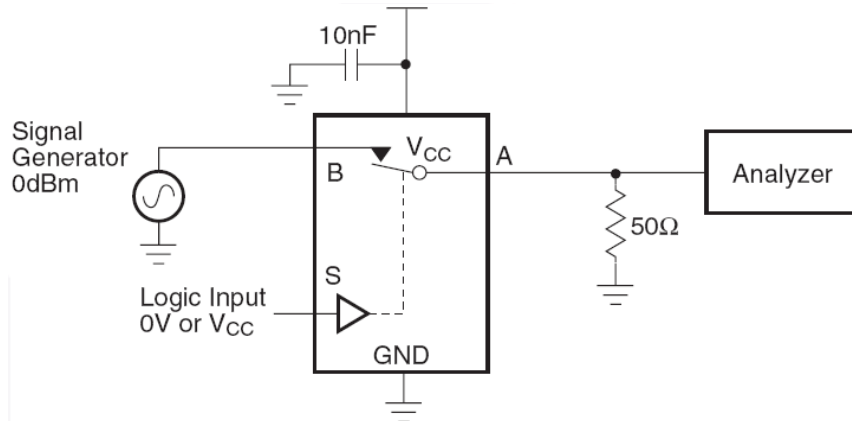

Figure 10. Bandwidth

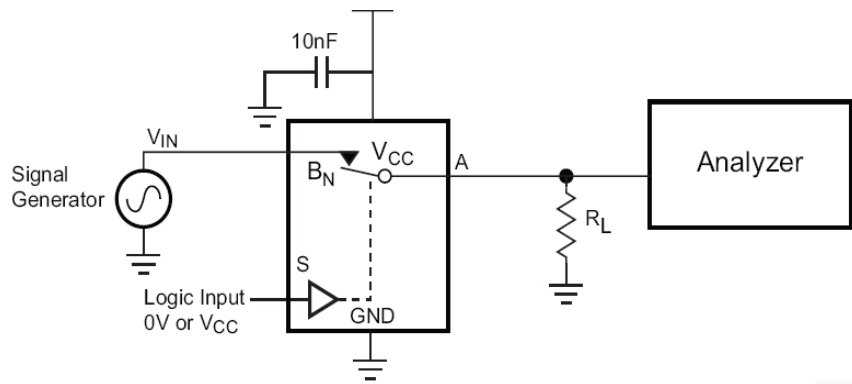

Figure 11. Harmonic Distortion

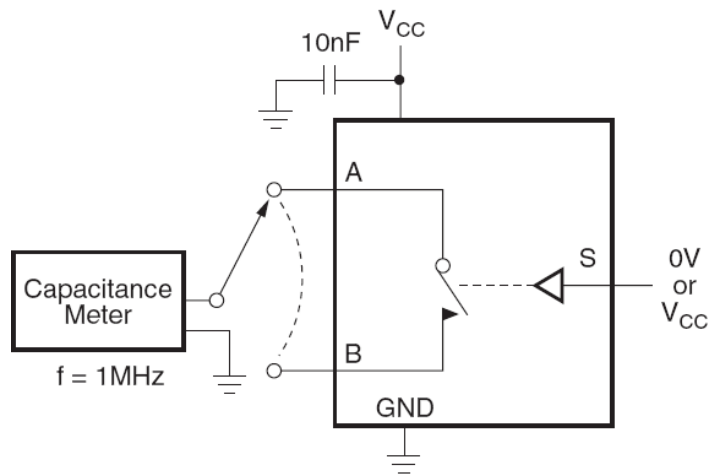

Figure 12. On / Off Capacitance

Physical Dimensions

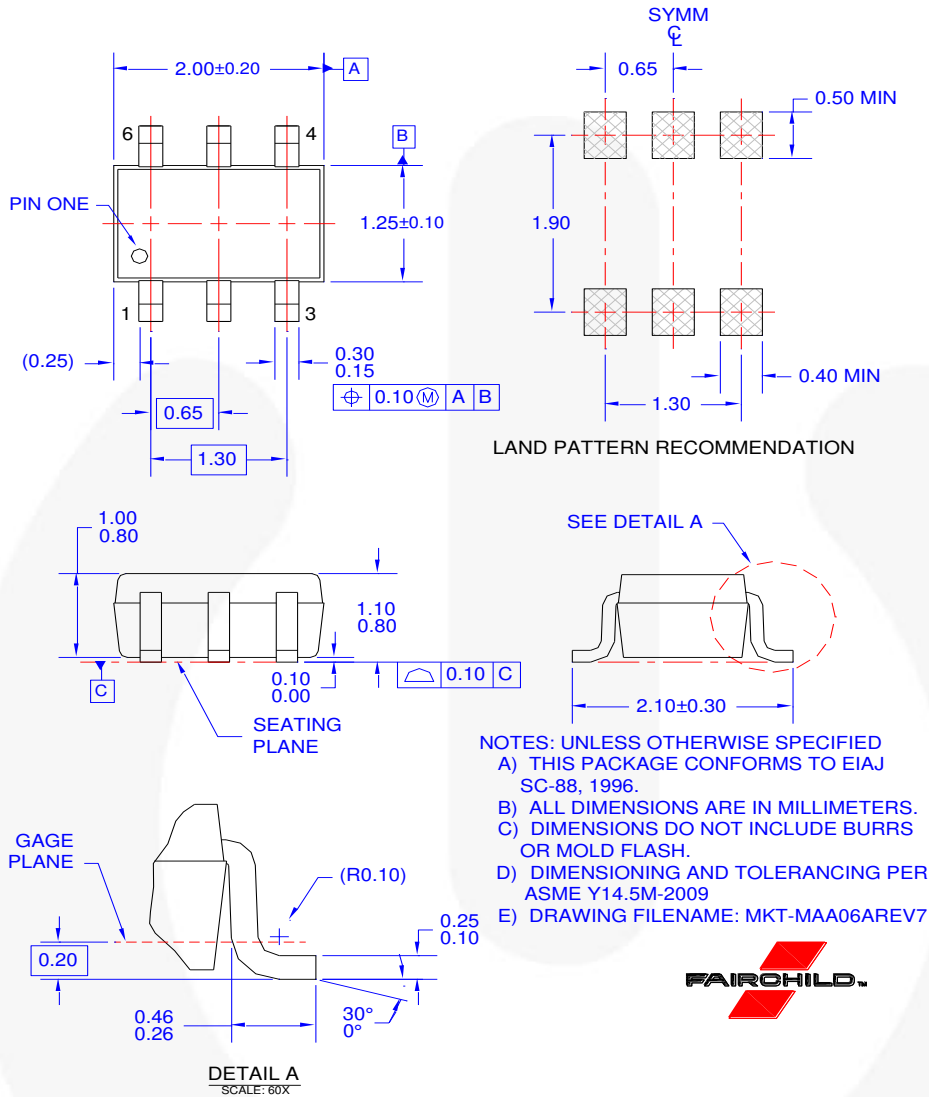

Figure 13. 6-Lead, SC70, EIAJ SC88 1.25mm Wide Package

Tape and Reel Specifications

Please visit Fairchild Semiconductor's online packaging area for the most recent tape and reel specifications:
http://www.fairchildsemi.com/products/analog/pdf/sc70-6_tr.pdf

Package Designator	Tape Section	Cavity Number	Cavity Status	Cover Type Status
P6X	Leader (Start End)	125 (Typical)	Empty	Sealed
	Carrier	3000	Filled	Sealed
	Trailer (Hub End)	75 (Typical)	Empty	Sealed

Physical Dimensions (Continued)

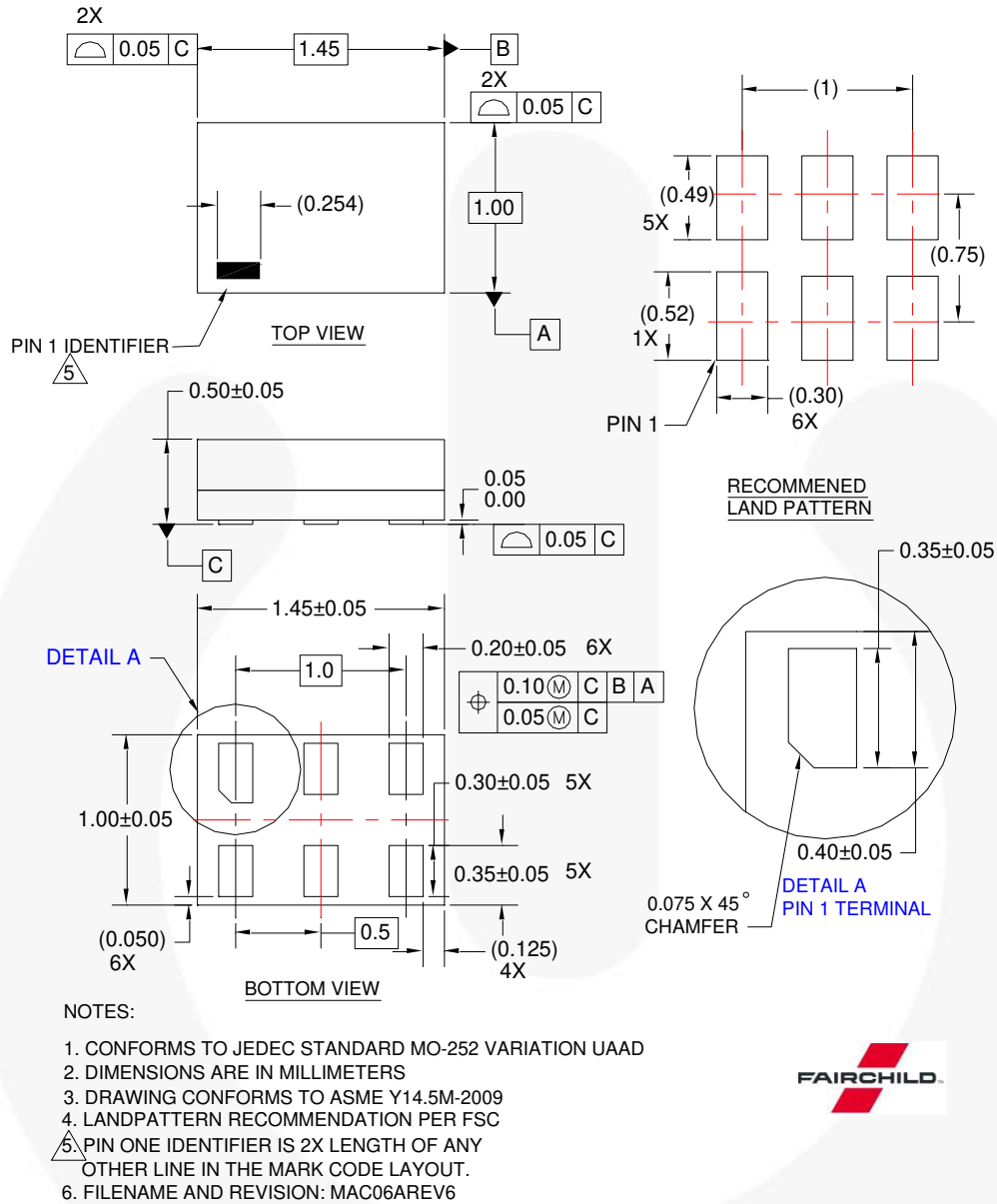

Figure 14. 6-Lead, Micropak™ 1.0mm Wide Package

Tape and Reel Specifications

Please visit Fairchild Semiconductor's online packaging area for the most recent tape and reel specifications:
http://www.fairchildsemi.com/products/logic/pdf/micropak_tr.pdf

Package Designator	Tape Section	Cavity Number	Cavity Status	Cover Type Status
L6X	Leader (Start End)	125 (Typical)	Empty	Sealed
	Carrier	5000	Filled	Sealed
	Trailer (Hub End)	75 (Typical)	Empty	Sealed



TRADEMARKS

The following includes registered and unregistered trademarks and service marks, owned by Fairchild Semiconductor and/or its global subsidiaries, and is not intended to be an exhaustive list of all such trademarks.

- | | | | |
|--------------------------|------------------------------------------------|---------------------------------------|------------------|
| AccuPower™ | F-PFS™ | OPTOPLANAR® | SYSTEM GENERAL® |
| AttitudeEngine™ | FRFET® | | TinyBoost® |
| Awinda® | Global Power Resource™ | Power Supply WebDesigner™ | TinyBuck® |
| AX-CAP®* | GreenBridge™ | PowerTrench® | TinyCalc™ |
| BitSiC™ | Green FPS™ | PowerXS™ | TinyLogic® |
| Build it Now™ | Green FPS™ e-Series™ | Programmable Active Droop™ | TINYOPTO™ |
| CorePLUS™ | Gmax™ | QFET® | TinyPower™ |
| CorePOWER™ | GTO™ | QS™ | TinyPWM™ |
| CROSSVOL™ | IntelliMAX™ | Quiet Series™ | TinyWire™ |
| CTL™ | ISOPLANAR™ | RapidConfigure™ | TranSiC™ |
| Current Transfer Logic™ | Making Small Speakers Sound Louder and Better™ | | TriFault Detect™ |
| DEUXPEED® | MegaBuck™ | Saving our world, 1mW/W/kW at a time™ | TRUECURRENT®* |
| Dual Cool™ | MICROCOUPLER™ | SignalWise™ | µSerDes™ |
| EcoSPARK® | MicroFET™ | SmartMax™ | |
| EfficientMax™ | MicroPak™ | SMART START™ | SerDes™ |
| ESBC™ | MicroPak2™ | Solutions for Your Success™ | UHC™ |
| | MillerDrive™ | SPM® | Ultra FRFET™ |
| Fairchild® | MotionMax™ | STEALTH™ | UniFET™ |
| Fairchild Semiconductor® | MotionGrid® | SuperFET® | VCX™ |
| FACT Quiet Series™ | MTI® | SuperSOT™-3 | VisualMax™ |
| FACT® | MTX® | SuperSOT™-6 | VoltagePlus™ |
| FastvCore™ | MVN® | SuperSOT™-8 | XS™ |
| FETBench™ | mVWSaver® | SupreMOS® | Xsens™ |
| FPS™ | OptoHiT™ | SyncFET™ | 仙童® |
| | OPTOLOGIC® | Sync-Lock™ | |

* Trademarks of System General Corporation, used under license by Fairchild Semiconductor.

DISCLAIMER

FAIRCHILD SEMICONDUCTOR RESERVES THE RIGHT TO MAKE CHANGES WITHOUT FURTHER NOTICE TO ANY PRODUCTS HEREIN TO IMPROVE RELIABILITY, FUNCTION, OR DESIGN. TO OBTAIN THE LATEST, MOST UP-TO-DATE DATASHEET AND PRODUCT INFORMATION, VISIT OUR WEBSITE AT [HTTP://WWW.FAIRCHILDSEMI.COM](http://www.fairchildsemi.com). FAIRCHILD DOES NOT ASSUME ANY LIABILITY ARISING OUT OF THE APPLICATION OR USE OF ANY PRODUCT OR CIRCUIT DESCRIBED HEREIN; NEITHER DOES IT CONVEY ANY LICENSE UNDER ITS PATENT RIGHTS, NOR THE RIGHTS OF OTHERS. THESE SPECIFICATIONS DO NOT EXPAND THE TERMS OF FAIRCHILD'S WORLDWIDE TERMS AND CONDITIONS, SPECIFICALLY THE WARRANTY THEREIN, WHICH COVERS THESE PRODUCTS.

AUTHORIZED USE

Unless otherwise specified in this data sheet, this product is a standard commercial product and is not intended for use in applications that require extraordinary levels of quality and reliability. This product may not be used in the following applications, unless specifically approved in writing by a Fairchild officer: (1) automotive or other transportation, (2) military/aerospace, (3) any safety critical application – including life critical medical equipment – where the failure of the Fairchild product reasonably would be expected to result in personal injury, death or property damage. Customer's use of this product is subject to agreement of this Authorized Use policy. In the event of an unauthorized use of Fairchild's product, Fairchild accepts no liability in the event of product failure. In other respects, this product shall be subject to Fairchild's Worldwide Terms and Conditions of Sale, unless a separate agreement has been signed by both Parties.

ANTI-COUNTERFEITING POLICY

Fairchild Semiconductor Corporation's Anti-Counterfeiting Policy. Fairchild's Anti-Counterfeiting Policy is also stated on our external website, www.fairchildsemi.com, under Terms of Use

Counterfeiting of semiconductor parts is a growing problem in the industry. All manufacturers of semiconductor products are experiencing counterfeiting of their parts. Customers who inadvertently purchase counterfeit parts experience many problems such as loss of brand reputation, substandard performance, failed applications, and increased cost of production and manufacturing delays. Fairchild is taking strong measures to protect ourselves and our customers from the proliferation of counterfeit parts. Fairchild strongly encourages customers to purchase Fairchild parts either directly from Fairchild or from Authorized Fairchild Distributors who are listed by country on our web page cited above. Products customers buy either from Fairchild directly or from Authorized Fairchild Distributors are genuine parts, have full traceability, meet Fairchild's quality standards for handling and storage and provide access to Fairchild's full range of up-to-date technical and product information. Fairchild and our Authorized Distributors will stand behind all warranties and will appropriately address any warranty issues that may arise. Fairchild will not provide any warranty coverage or other assistance for parts bought from Unauthorized Sources. Fairchild is committed to combat this global problem and encourage our customers to do their part in stopping this practice by buying direct or from authorized distributors.

PRODUCT STATUS DEFINITIONS

Definition of Terms

Datasheet Identification	Product Status	Definition
Advance Information	Formative / In Design	Datasheet contains the design specifications for product development. Specifications may change in any manner without notice.
Preliminary	First Production	Datasheet contains preliminary data; supplementary data will be published at a later date. Fairchild Semiconductor reserves the right to make changes at any time without notice to improve design.
No Identification Needed	Full Production	Datasheet contains final specifications. Fairchild Semiconductor reserves the right to make changes at any time without notice to improve the design.
Obsolete	Not In Production	Datasheet contains specifications on a product that is discontinued by Fairchild Semiconductor. The datasheet is for reference information only.

Rev. 177

ON Semiconductor and  are trademarks of Semiconductor Components Industries, LLC dba ON Semiconductor or its subsidiaries in the United States and/or other countries. ON Semiconductor owns the rights to a number of patents, trademarks, copyrights, trade secrets, and other intellectual property. A listing of ON Semiconductor's product/patent coverage may be accessed at www.onsemi.com/site/pdf/Patent-Marking.pdf. ON Semiconductor reserves the right to make changes without further notice to any products herein. ON Semiconductor makes no warranty, representation or guarantee regarding the suitability of its products for any particular purpose, nor does ON Semiconductor assume any liability arising out of the application or use of any product or circuit, and specifically disclaims any and all liability, including without limitation special, consequential or incidental damages. Buyer is responsible for its products and applications using ON Semiconductor products, including compliance with all laws, regulations and safety requirements or standards, regardless of any support or applications information provided by ON Semiconductor. "Typical" parameters which may be provided in ON Semiconductor data sheets and/or specifications can and do vary in different applications and actual performance may vary over time. All operating parameters, including "Typicals" must be validated for each customer application by customer's technical experts. ON Semiconductor does not convey any license under its patent rights nor the rights of others. ON Semiconductor products are not designed, intended, or authorized for use as a critical component in life support systems or any FDA Class 3 medical devices or medical devices with a same or similar classification in a foreign jurisdiction or any devices intended for implantation in the human body. Should Buyer purchase or use ON Semiconductor products for any such unintended or unauthorized application, Buyer shall indemnify and hold ON Semiconductor and its officers, employees, subsidiaries, affiliates, and distributors harmless against all claims, costs, damages, and expenses, and reasonable attorney fees arising out of, directly or indirectly, any claim of personal injury or death associated with such unintended or unauthorized use, even if such claim alleges that ON Semiconductor was negligent regarding the design or manufacture of the part. ON Semiconductor is an Equal Opportunity/Affirmative Action Employer. This literature is subject to all applicable copyright laws and is not for resale in any manner.

PUBLICATION ORDERING INFORMATION

LITERATURE FULFILLMENT:

Literature Distribution Center for ON Semiconductor
19521 E. 32nd Pkwy, Aurora, Colorado 80011 USA
Phone: 303-675-2175 or 800-344-3860 Toll Free USA/Canada
Fax: 303-675-2176 or 800-344-3867 Toll Free USA/Canada
Email: orderlit@onsemi.com

N. American Technical Support: 800-282-9855 Toll Free
USA/Canada
Europe, Middle East and Africa Technical Support:
Phone: 421 33 790 2910
Japan Customer Focus Center
Phone: 81-3-5817-1050

ON Semiconductor Website: www.onsemi.com
Order Literature: <http://www.onsemi.com/orderlit>
For additional information, please contact your local
Sales Representative