

REVISIONS				
REV.	ECO. NO	DESCRIPTION	DATE	BY
A	2403	INITIAL RELEASE	7/11/2011	JH

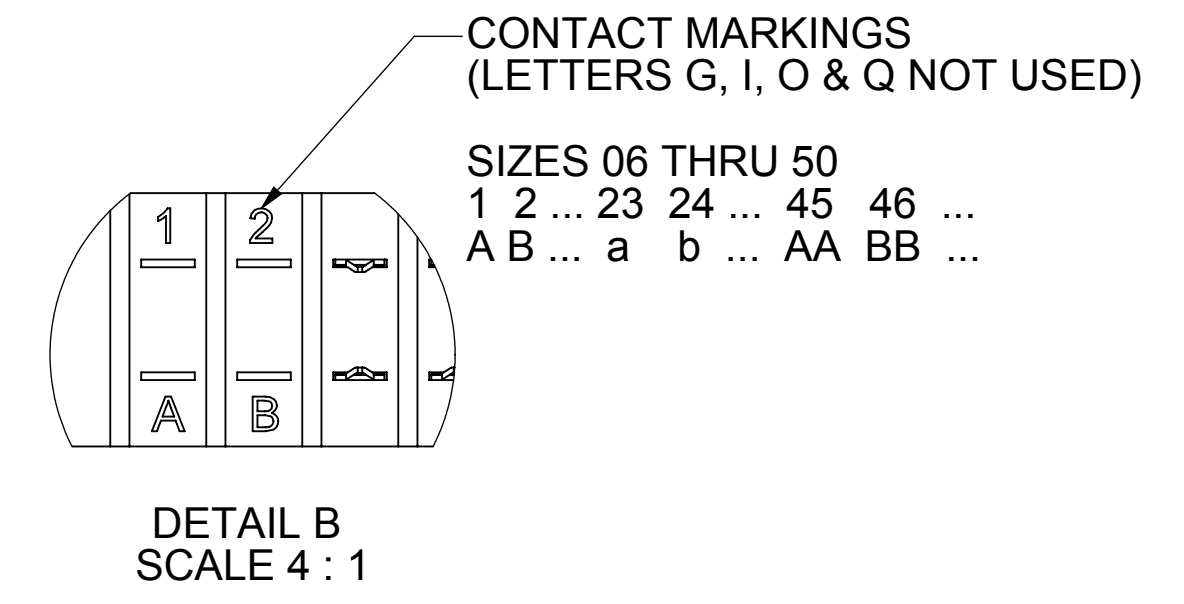
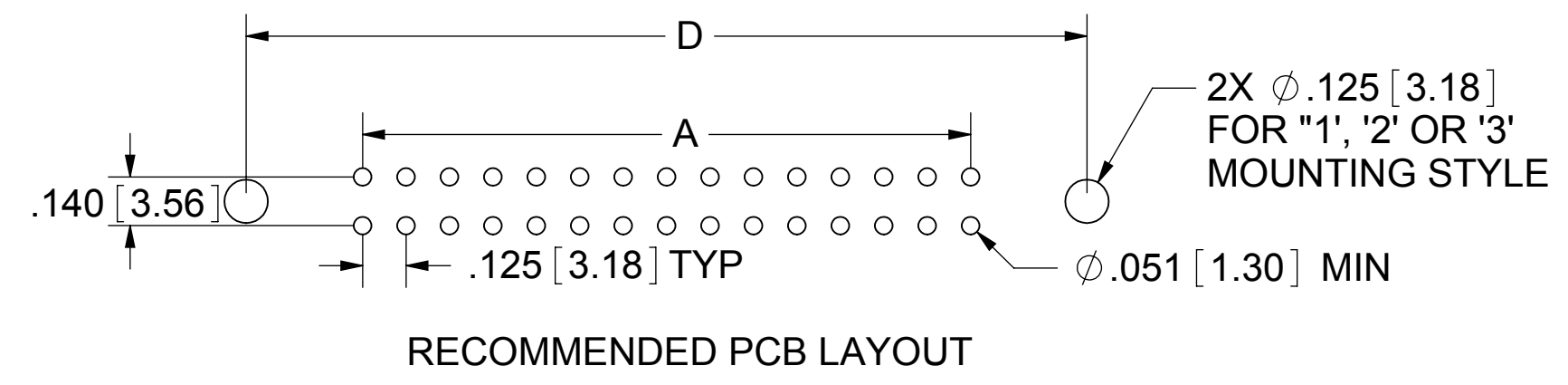
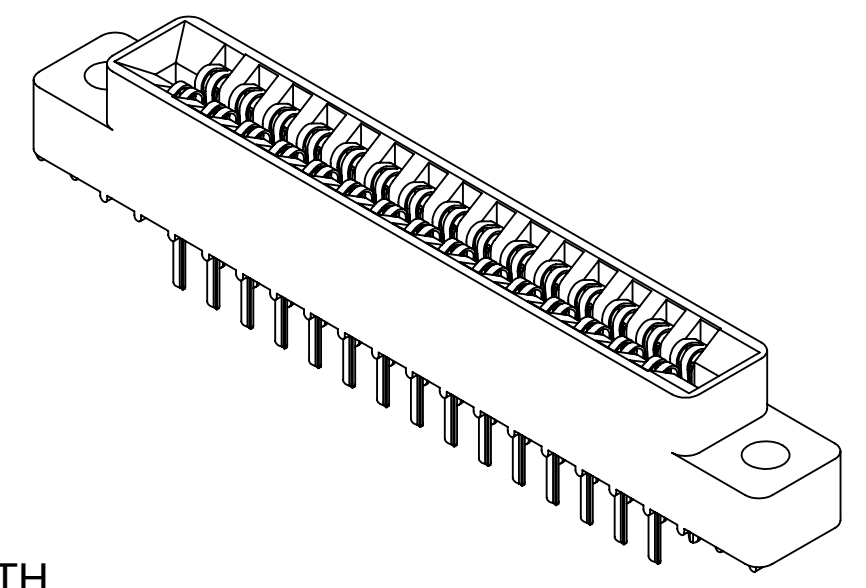
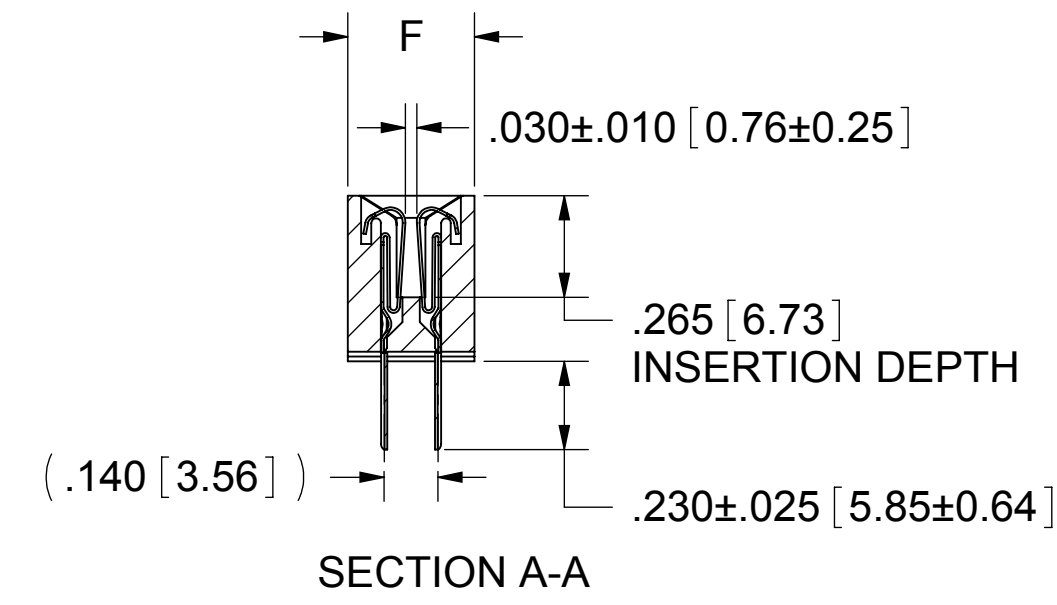
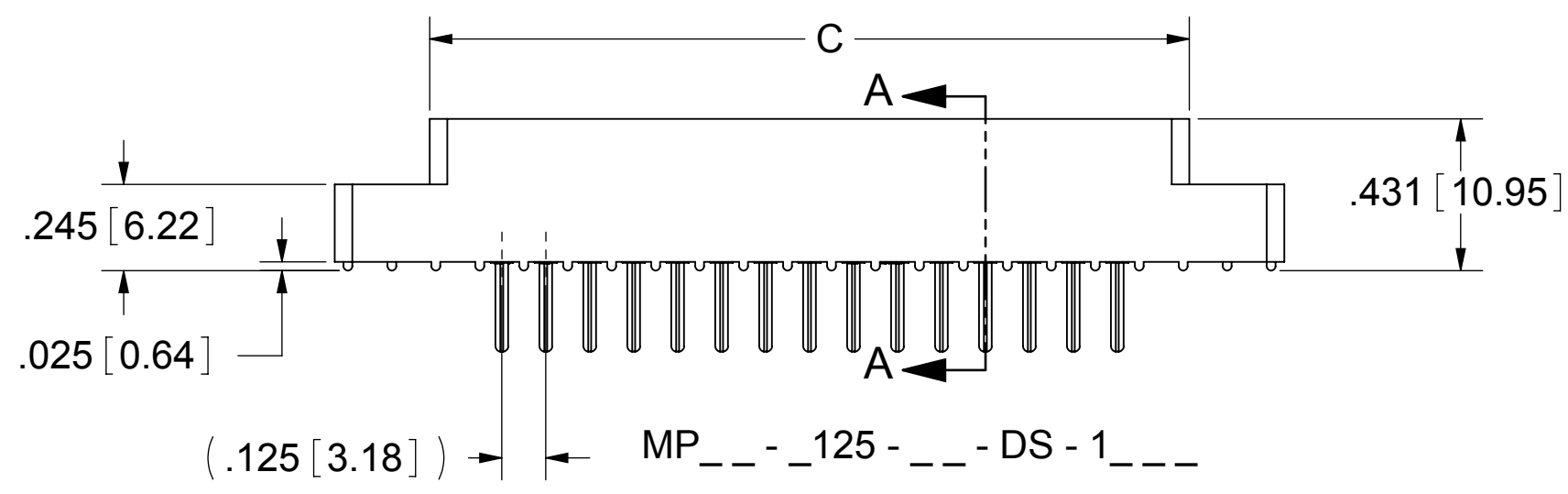
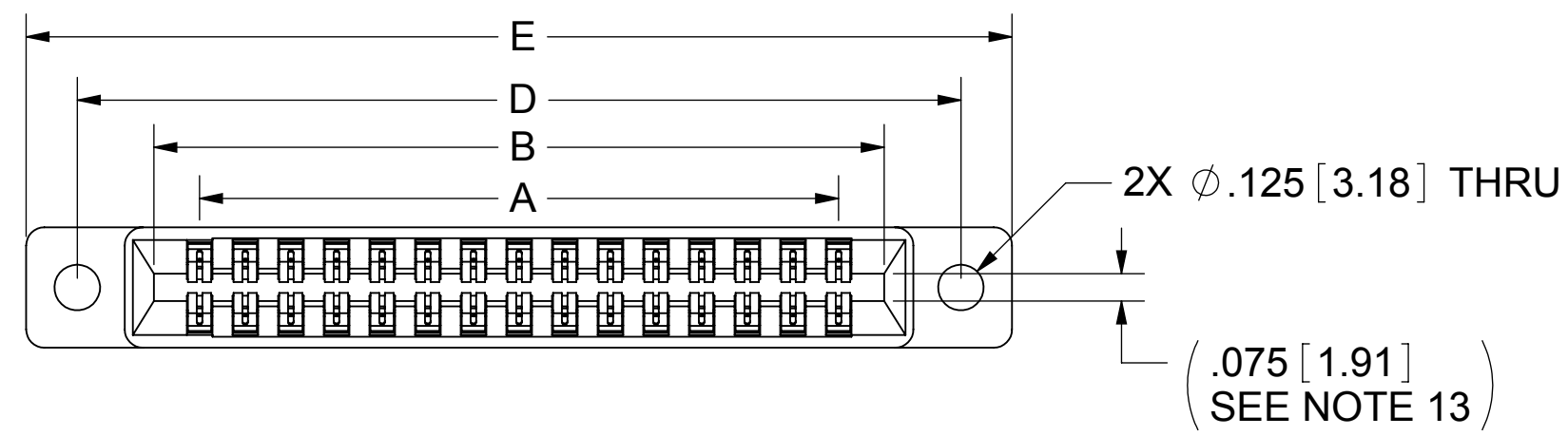

- NOTES:
1. INSULATOR MATERIAL: SEE PART NUMBER CODING
 2. CONTACT MATERIAL: SEE PART NUMBER CODING
 3. PLATING: SEE PART NUMBER CODING
 4. OPERATING TEMPERATURE: SEE PART NUMBER CODING
 5. PROCESSING TEMP: SEE PART NUMBER CODING
 6. UL FLAMMABILITY RATING: 94V-0
 7. DIELECTRIC WITHSTANDING VOLTAGE: 750 VAC MINIMUM AT SEA LEVEL
 8. CURRENT RATING: 3 AMP PER CONTACT
 9. CONTACT RESISTANCE: 30 MILLI OHMS MAX
 10. INSULATION RESISTANCE: 5000 MEGA OHMS
 11. DURABILITY: 500 CYCLES MIN
 12. CONNECTOR IDENTIFICATION: THE PART SHALL BE MARKED WITH A PART NUMBER AND LOT CODE
 13. BOARD THICKNESS ACCOMMODATED: $.062 \pm .008$ [1.57 ± 0.20]
 14. INSERTION FORCE: 16 OZ MAX PER CONTACT PAIR WHEN USING A $.062$ [1.57] TEST BLADE
INTERNAL INSPECTION TO BE PER SULLIN'S WORK INSTRUCTION WI7.3-01
 15. WITHDRAWAL FORCE: 1 OZ MIN PER CONTACT PAIR USING $.062$ [1.57] PCB

REF: __ A __ DRV __ P __

CUSTOMER COPY



UNLESS OTHERWISE SPECIFIED: DIMENSIONS ARE IN INCHES [MM]	DRAWN	DATE	NAME	
		7/11/2011	JH	
TOLERANCES: ANGULAR: $\pm 30'$ $.XX = \pm .02$ [5] $.XXX = \pm .005$ [13] $.XXXX = \pm .0005$ [013]	<small>THE INFORMATION HEREIN CONTAINS PROPRIETARY INFORMATION OF SULLINS ELECTRONICS AND IS NOT TO BE REPRODUCED, USED OR DISCLOSED TO OTHERS FOR ANY PURPOSE EXCEPT AS SPECIFICALLY AUTHORIZED IN WRITING BY AN OFFICER OF SULLINS ELECTRONICS.</small>			TITLE
	INTERPRET DIMENSIONS AND TOLERANCING PER: ASME Y14.5M-2009			CONNECTOR, .125 CC LP
PART NUMBER				REV
MP__ - _125 - _ - DS - _				A
SIZE	CAGE CODE	DWG. NO.		
C	54453	C11815		
SCALE: 2:1	SHEET 1 OF 3			

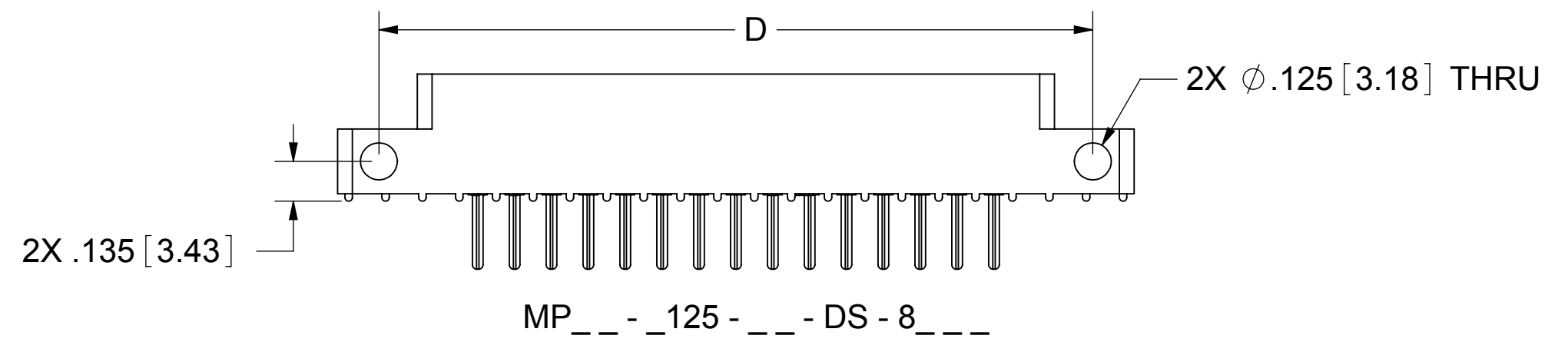
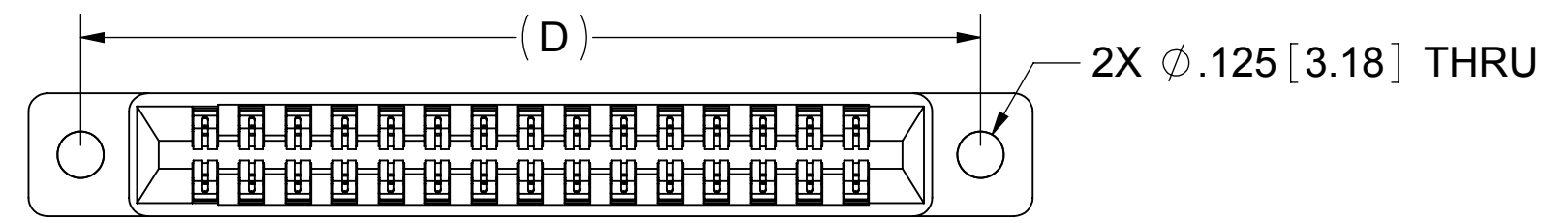
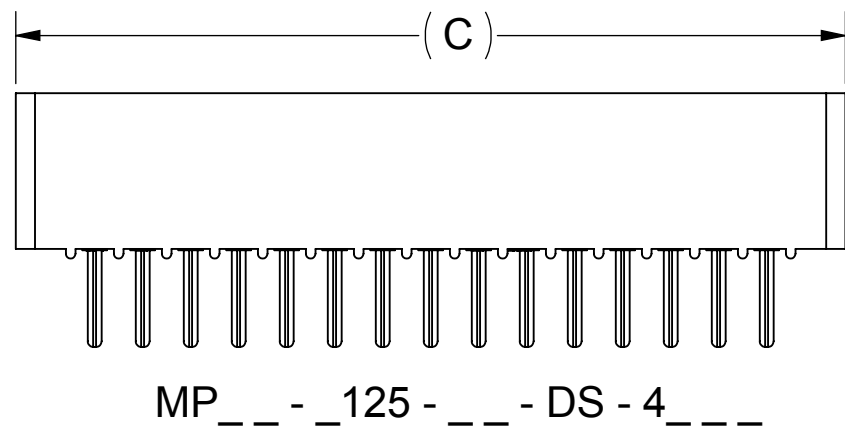
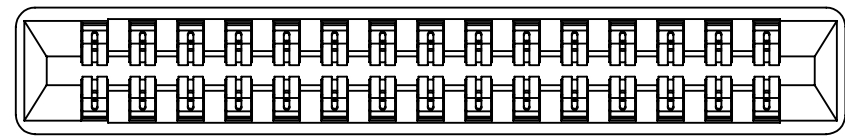
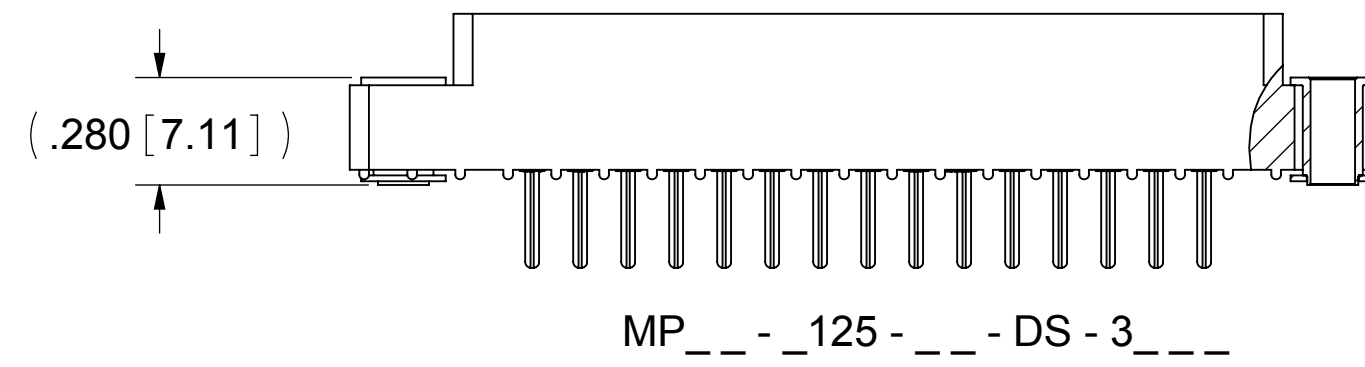
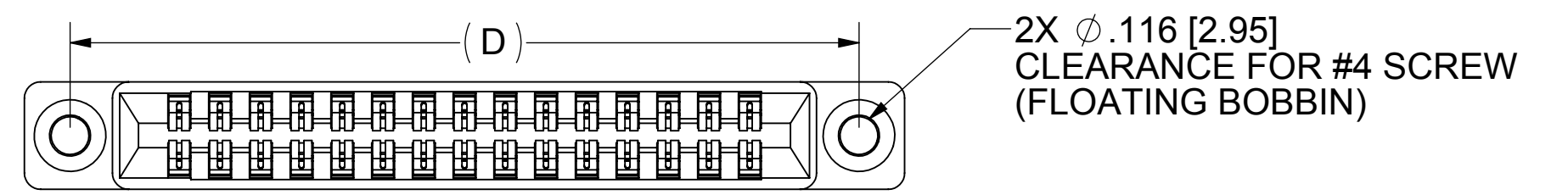
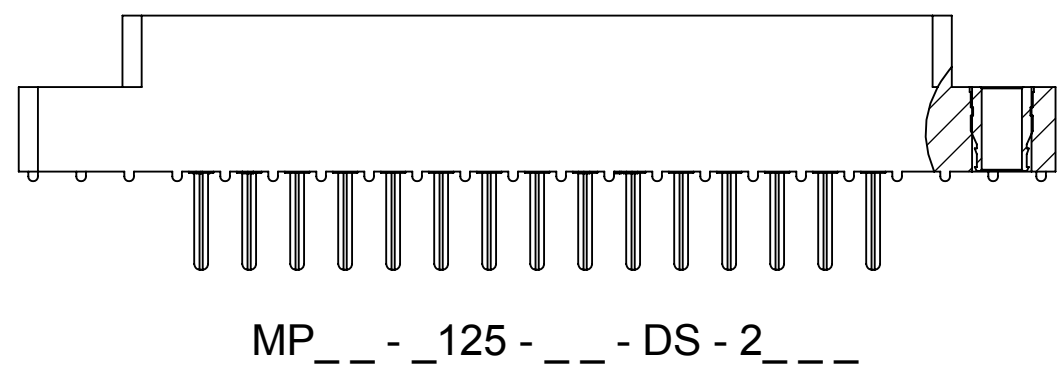
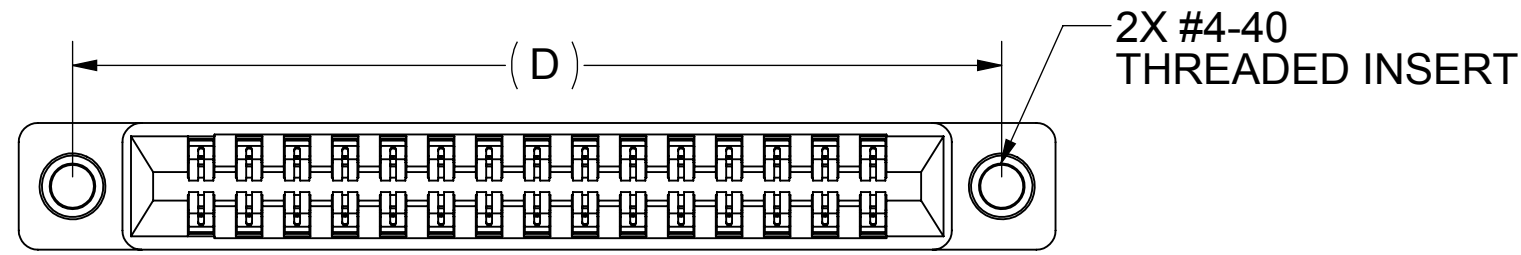

CUSTOMER COPY

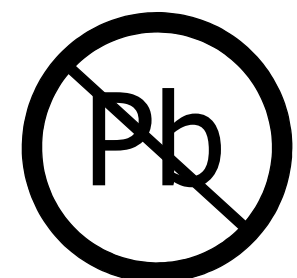

RoHS COMPLIANT

UNLESS OTHERWISE SPECIFIED: DIMENSIONS ARE IN INCHES [MM]	DRAWN	DATE	NAME		
		7/11/2011	JH		
TOLERANCES: ANGULAR: \pm 30' .XX= \pm .02 [.5] .XXX= \pm .005 [.13] .XXXX= \pm .0005 [.013]	<small>THE INFORMATION HEREIN CONTAINS PROPRIETARY INFORMATION OF SULLINS ELECTRONICS AND IS NOT TO BE REPRODUCED, USED OR DISCLOSED TO OTHERS FOR ANY PURPOSE EXCEPT AS SPECIFICALLY AUTHORIZED IN WRITING BY AN OFFICER OF SULLINS ELECTRONICS.</small>			TITLE	CONNECTOR, .125 CC LP
	INTERPRET DIMENSIONS AND TOLERANCING PER: ASME Y14.5M-2009			PART NUMBER	MP__ - _125 - ___ - DS - ___
	SIZE	CAGE CODE	DWG. NO.	REV	
	C	54453	C11815	A	
	SCALE: 2:1			SHEET 2 OF 3	

PART NUMBER	A±.008[0.20]		B±.008[0.20]		C±.015[0.38]		D±.010[0.25]		E±.020[0.51]		F+.005[0.13]/-.015[0.38]	
	INCH	MM	INCH	MM	INCH	MM	INCH	MM	INCH	MM	INCH	MM
MP - 125-06-DS	0.625	15.88	0.875	22.23	1.035	26.29	1.295	32.89	1.575	40.01	0.330	8.38
MP - 125-10-DS	1.125	28.58	1.375	34.93	1.535	38.99	1.795	45.59	2.075	52.71		
MP - 125-14-DS	1.625	41.28	1.875	47.63	2.035	51.69	2.295	58.29	2.575	65.41		
MP - 125-15-DS	1.750	44.45	2.000	50.80	2.160	54.86	2.420	61.47	2.700	68.58		
MP - 125-18-DS	2.125	53.98	2.375	60.33	2.535	64.39	2.795	70.99	3.075	78.11		
MP - 125-22-DS	2.625	66.68	2.875	73.03	3.035	77.09	3.295	83.69	3.575	90.81		
MP - 125-28-DS	3.375	85.73	3.625	92.08	3.785	96.14	4.045	102.74	4.325	109.86		
MP - 125-30-DS	3.625	92.08	3.875	98.43	4.035	102.49	4.295	109.09	4.575	116.21		
MP - 125-31-DS	3.750	95.25	4.000	101.60	4.160	105.66	4.420	112.27	4.700	119.38		
MP - 125-35-DS	4.250	107.95	4.500	114.30	4.660	118.36	4.920	124.97	5.200	132.08		
MP - 125-36-DS	4.375	111.13	4.625	117.48	4.785	121.54	5.045	128.14	5.325	135.26		
MP - 125-37-DS	4.500	114.30	4.750	120.65	4.910	124.71	5.170	131.32	5.450	138.43		
MP - 125-40-DS	4.875	123.83	5.125	130.18	5.285	134.24	5.545	140.84	5.825	147.96		
MP - 125-43-DS	5.250	133.35	5.500	139.70	5.660	143.76	5.920	150.37	6.200	157.48		
MP - 125-44-DS	5.375	136.53	5.625	142.88	5.785	146.94	6.045	153.54	6.325	160.66		
MP - 125-49-DS	6.000	152.40	6.250	158.75	6.410	162.81	6.670	169.42	6.950	176.53		
MP - 125-50-DS	6.125	155.58	6.375	161.93	6.535	165.99	6.795	172.59	7.075	179.71		
											0.370	9.40

PART NUMBER CODING

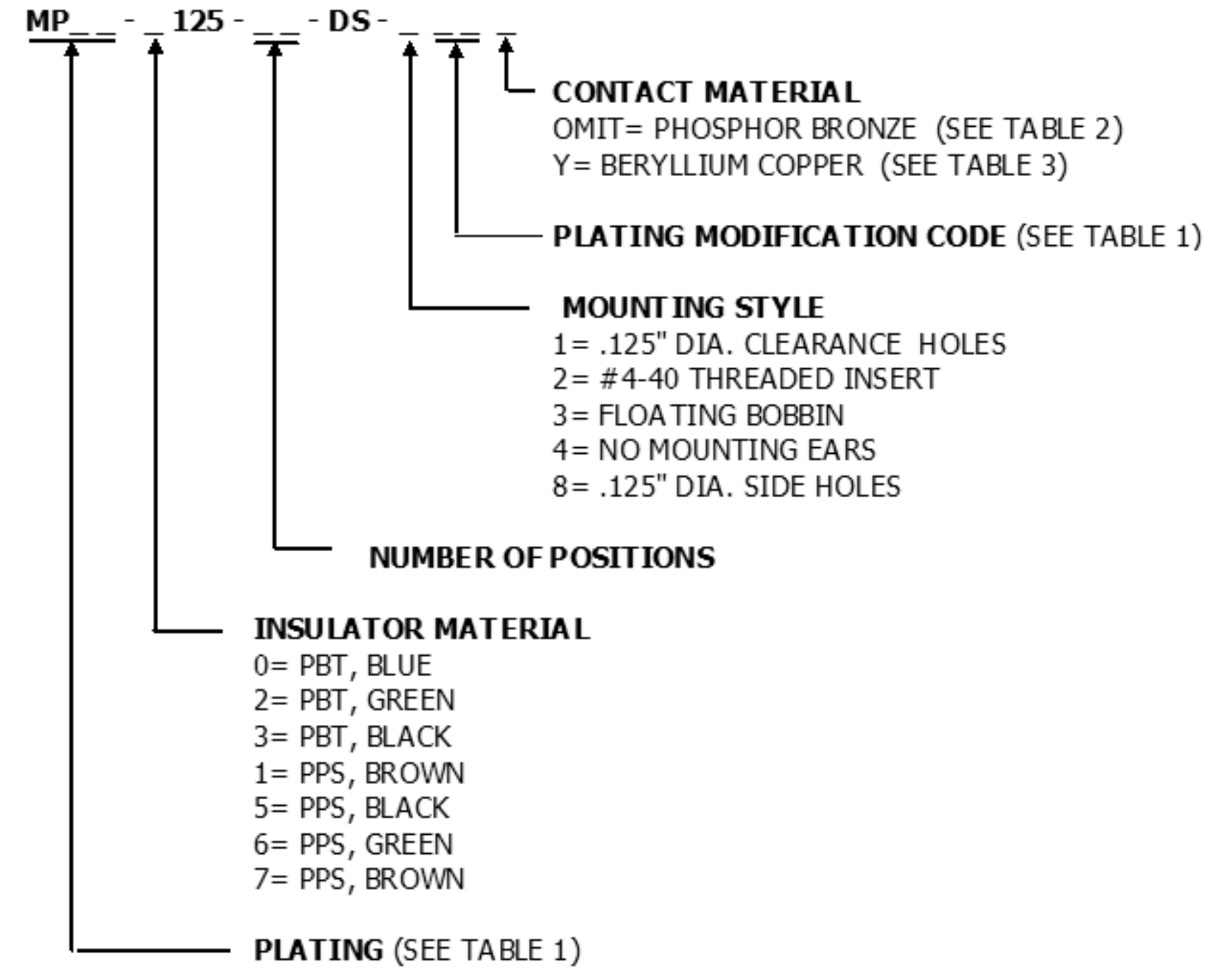

TABLE 1 (PLATING):

ALL PLATINGS HAVE .000050" NICKEL UNDERPLATE

	CONTACT SURFACE	TERMINATION	PLATING MODIFICATION CODE
MP	.000010" GOLD OVERALL		OMIT
	.000030" GOLD	.000010" GOLD OVERALL	G
MPSL	.000010" GOLD	.000100" PURE TIN, MATTE	K
	.000030" GOLD	.000100" PURE TIN, MATTE	GK
MPL	.000100" PURE TIN, MATTE OVERALL		K

(MPL PLATING AVAILABLE WITH PHOSPHOR BRONZE CONTACTS ONLY)

TABLE 2 (PHOSPHOR BRONZE CONTACTS):

INSULATOR MATERIAL CODE	OPERATING TEMPERATURE	PROCESSING TEMPERATURE
0, 2, 3	-65°C TO +125°C	260°C FOR 10 SEC MAX (230°C, 30 SEC)
1, 5, 6, 7	-65°C TO +125°C	260°C FOR 120 SEC MAX

TABLE 3 (BERYLLIUM COPPER CONTACTS):

INSULATOR MATERIAL CODE	OPERATING TEMPERATURE	PROCESSING TEMPERATURE
0, 2, 3	-65°C TO +125°C	260°C FOR 10 SEC MAX (230°C, 30 SEC)
1, 5, 6, 7	-65°C TO +150°C	260°C FOR 120 SEC MAX

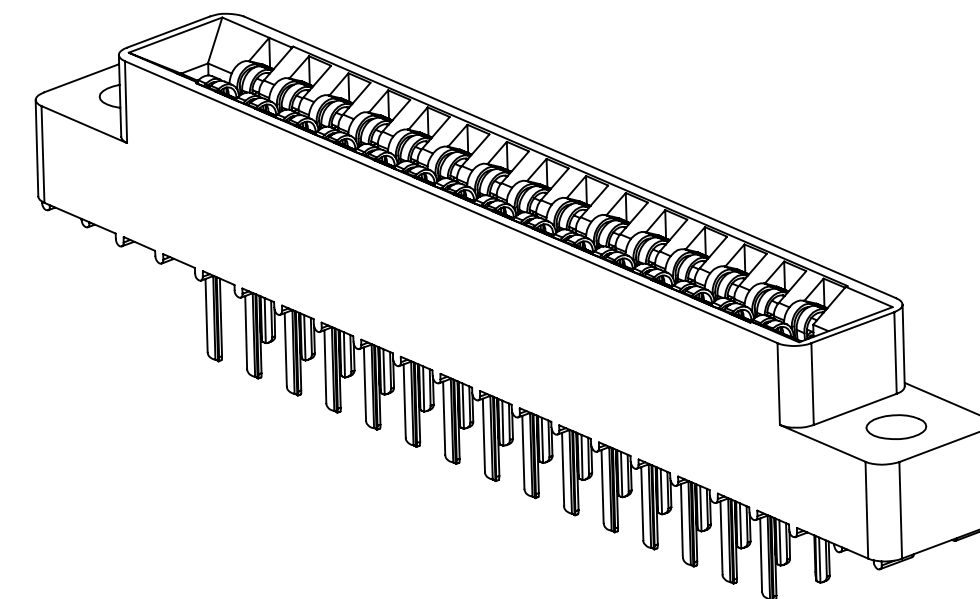

CUSTOMER COPY

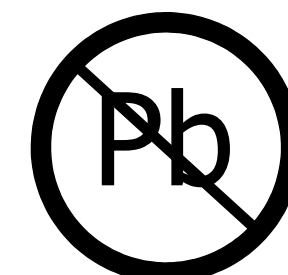

RoHS COMPLIANT

UNLESS OTHERWISE SPECIFIED: DIMENSIONS ARE IN INCHES [MM]	DRAWN	DATE	NAME	
		7/11/2011	JH	
TOLERANCES: ANGULAR: ± 30' .XX=± .02 [.5] .XXX=± .005 [.13] .XXXX=± .0005 [.013]	THE INFORMATION HEREIN CONTAINS PROPRIETARY INFORMATION OF SULLINS ELECTRONICS AND IS NOT TO BE REPRODUCED, USED OR DISCLOSED TO OTHERS FOR ANY PURPOSE EXCEPT AS SPECIFICALLY AUTHORIZED IN WRITING BY AN OFFICER OF SULLINS ELECTRONICS.			TITLE
	INTERPRET DIMENSIONS AND TOLERANCING PER: ASME Y14.5M-2009			CONNECTOR, .125 CC LP
PART NUMBER				REV
MP - 125 - DS -				A
SIZE	CAGE CODE	DWG. NO.	REV	
C	54453	C11815	A	
SCALE: 2.5:1				SHEET 3 OF 3