

# IB IL 24 FLM-PAC

## Branch Terminal for Integrating a Fieldline Modular Local Bus in an Inline Station or for Local Bus Extension of an Inline Station

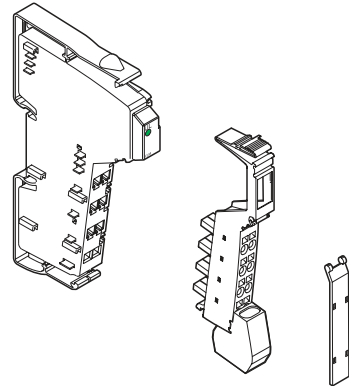

### AUTOMATION

Data Sheet  
7240\_en\_05

© PHOENIX CONTACT 2010-11-17

## 1 Description

The terminal is designed for use within an Inline station.

This terminal can be used to implement two different tasks:

### 1. Integration of a Fieldline Modular local bus in an Inline station

This terminal can be used to integrate sensors and actuators in close proximity to the station, which are connected to the Fieldline Modular M8 or M12 local bus with IP65/67 protection, in your bus system.

### 2. Local bus extension in combination with the IB IL 24 LSKIP (-PAC) Inline local bus extension terminal

In combination with the IB IL 24 LSKIP (-PAC) terminal, this terminal can be used to extend an Inline station by one or more rows. The IB IL 24 FLM-PAC terminal is installed at the end of an Inline station row and the IB IL 24 LSKIP (-PAC) terminal at the beginning of the following row (see also data sheet for the IB IL 24 LSKIP (-PAC) terminal).

## Features

- **When integrating a Fieldline Modular local bus**  
Conversion of the physical transmission method of the Inline local bus to the physical transmission method of the Fieldline Modular local bus
- **When used for local bus extension**  
Data transmission between the IB IL 24 FLM-PAC and IB IL 24 LSKIP (-PAC) terminals via the RS-422 protocol



This data sheet is only valid in association with the IL SYS INST UM E user manual or the Inline system manual for your bus system.

When connecting a Fieldline Modular local bus, please refer to the technical data for this product group. This can be found in the device-specific data sheets and in the user manuals.



When using the IB IL 24 LSKIP (-PAC) terminal, please observe the information in the terminal-specific data sheet. Make sure you always use the latest documentation.

It can be downloaded at [www.phoenixcontact.net/catalog](http://www.phoenixcontact.net/catalog).

A conversion table is available on the Internet at

[www.download.phoenixcontact.com/general/7000\\_en\\_00.pdf](http://www.download.phoenixcontact.com/general/7000_en_00.pdf).

## – General

**NOTE:**

**Only use the branch terminal as the last terminal in an Inline station or as the last terminal of an Inline station row.**

The data jumpers for the local bus are **not** available after the branch terminal. If terminals are snapped on after the branch terminal, the first INTERBUS device after the branch terminal indicates an interface error (D LED flashes at 4 Hz). In this case, change the Inline station so that the branch terminal is the last terminal in the station.



This terminal does not have a protocol chip and therefore is not a bus device.

The Inline system limits apply to the entire station regardless of the number of rows in the station.

## 2 Ordering Data

### Product

Description	Type	Order No.	Pcs./Pck.
Branch terminal for integrating a Fieldline Modular local bus in an Inline station, complete with accessories (connector and labeling field)	IB IL 24 FLM-PAC	2736903	1

### Accessories

Description	Type	Order No.	Pcs./Pck.
Inline segment terminal with fuse and diagnostics; complete with accessories (connector and labeling field)	IB IL 24 SEG/F-D-PAC	2861904	1
Fuse	SI 5x20 6,3 A T DIN 41662	2726104	1
Inline local bus extension terminal; complete with accessories (connectors and labeling fields)	IB IL 24 LSKIP (-PAC)	2897457	1
Standard remote bus cable for permanent installation	IBS RBC METER-T	2806286	Sold by the meter
Remote bus cable for flexible applications	IBS RBC METER/F-T	2723123	Sold by the meter

### Documentation

Description	Type
"Automation Terminals of the Inline Product Range" user manual	IL SYS INST UM E
"Configuring and Installing the INTERBUS Inline Product Range" user manual	IB IL SYS PRO UM E
"Installation of Devices in the Fieldline Product Range" user manual	FLS FLM SYS INST UM E
"Inline Local Bus Extension Terminal" data sheet	DB EN IB IL 24 LSKIP (-PAC)

### 3 Technical Data

#### General Data

Housing dimensions (width x height x depth; with connector)	12.2 mm x 134 mm x 72 mm
Weight (with connector)	43 g
Ambient temperature (operation)	-25°C to +55°C
Ambient temperature (operation/storage/transport)	-25°C to +85°C
Permissible humidity (storage/transport)	10% to 95%, according to EN 61131-2
Permissible air pressure (operation/storage/transport)	70 kPa to 106 kPa (up to 3000 m above sea level)
Degree of protection	IP20 according to IEC 60529
Protection class	Class 3 according to EN 61131-2, IEC 61131-2
Connection data for Inline connectors	
Connection method	Spring-cage terminals
Conductor cross-section	0.2 mm <sup>2</sup> to 1.5 mm <sup>2</sup> (solid or stranded), 24 - 16 AWG

#### Interfaces

Local bus	Through data routing
Fieldline Modular M8 system	
Cable (common system cable for bus and supply)	2 x 2-pos., shielded twisted pair, plus common braided shield (e.g., type SAC-4P-950/..., Order No. 1543401)
Permissible cable cross-section	
- Bus	0.14 mm <sup>2</sup> , minimum
- Voltage	0.34 mm <sup>2</sup> , minimum
Maximum cable length	40 m
Fieldline Modular M12 system	
Bus cable	5-pos., shielded twisted pair, plus common braided shield (e.g., type IBS RBC METER/F-T, Order No. 1511491)
Supply cable	5-pos. (supply, e.g., type SAC-5P-100,0-186/0,75, Order No. 1535590)
Permissible cable cross-section	
- Bus	0.25 mm <sup>2</sup> , minimum
- Supply	0.75 mm <sup>2</sup> , minimum
Maximum cable length	20 m
In combination with the IB IL 24 LSKIP (-PAC) terminal	
Cable	Standard INTERBUS cable
Maximum cable length	20 m (total cable length between the first IB IL 24 FLM-PAC and the last IB IL 24 LSKIP (-PAC) of an Inline station)

#### Transmission Speed

Can be used in Inline stations with the following transmission speed	500 kbps or 2 Mbps
--	--------------------

#### Power Consumption

Communications power $U_L$	7.5 V
Current consumption at $U_L$	110 mA
Power consumption at $U_L$	825 mW
Segment supply voltage $U_S$	24 V DC (nominal value)
Nominal current consumption at $U_S$	
Fieldline Modular M8 local bus	3 A, maximum (with supply via return line) 4 A, maximum (with simultaneous supply; 2 A, maximum each for forward and return line)
Fieldline Modular M12 local bus	4 A, maximum total ( $U_L$ and $U_S$ ); not relevant for separate supply to the first FLM device
Internal	55 mA, maximum

#### Supply of the Module Electronics and I/O Through Bus Coupler/Power Terminal

Connection method	Through potential routing
-------------------	---------------------------

### Special Demands on the Voltage Supply

When installing a Fieldline Modular M8 system, insert a segment terminal with fuse and diagnostics directly before the IB IL 24 FLM-PAC terminal (see "Ordering Data" on page 2). The supply voltage for the Fieldline Modular system is thus protected and diagnostics can be performed for the supply voltage.

When installing a Fieldline Modular M12 system, supply the supply voltage  $U_{LS}$  separately at the first FLM device, if possible, in order to use the maximum permissible logic and sensor current of 4 A each for the FLM station.

### Safety Equipment

Overload in local bus ring	Yes; by fuse in the preconnected IB IL 24 SEG/F-D-PAC segment terminal
Protection against polarity reversal	Yes; by protective elements in the preconnected IB IL 24 SEG/F-D-PAC segment terminal
Short-circuit protection	Yes; by fuse in the preconnected IB IL 24 SEG/F-D-PAC segment terminal

### Electrical Isolation/Isolation of the Voltage Areas

#### Common Potentials

The 24 V main voltage, 24 V segment voltage, and GND have the same potential. FE is a separate potential area.

#### Separate Potentials in the System Consisting of Bus Coupler/Power Terminal and I/O Terminal

##### Test Distance

Functional earth ground/Fieldline Modular M8 local bus

Functional earth ground/Inline (7.5 V supply  $U_L$ )

Inline (7.5 V supply  $U_L$ )/Fieldline Modular M8 local bus

##### Test Voltage

500 V AC, 50 Hz, 1 min.

500 V AC, 50 Hz, 1 min.

500 V AC, 50 Hz, 1 min.

### Error Messages to the Higher-Level Control or Computer System

Yes Via preconnected IB IL 24 SEG/F-D-PAC segment terminal

### Approvals

For the latest approvals, please visit [www.phoenixcontact.net/catalog](http://www.phoenixcontact.net/catalog).

## 4 Local Diagnostic Indicator and Terminal Point Assignment

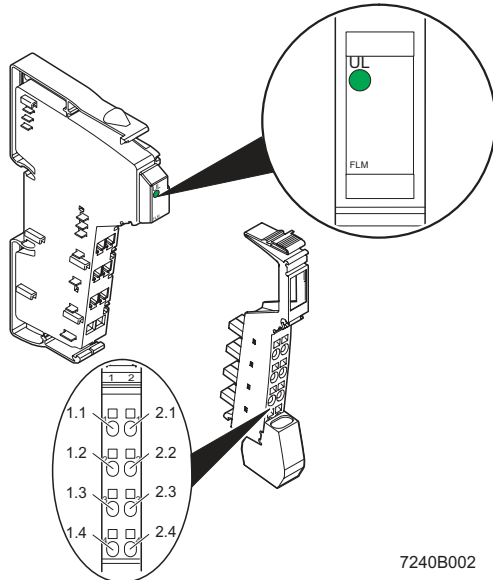

7240B002

Figure 1 IB IL 24 FLM-PAC terminal

### 4.1 Local Diagnostic Indicator

Designation	Color	
UL	green	Communications power present

### 4.2 Function Identification

Orange

### 4.3 Terminal Point Assignment

Terminal Point	Assignment	Conductor Color for the Connection of		
		M8	M12*	LSKIP*
<b>Forward Line, Local Bus</b>				
1.1	/DO	Pin 4 green	Pin 2 green	green
2.1	DO	Pin 2 yellow	Pin 1 yellow	yellow
<b>Return Line, Local Bus</b>				
1.2	/DI	Pin 4 green	Pin 4 pink	pink
2.2	DI	Pin 2 yellow	Pin 3 gray	gray
1.3	GND (FLM)		Pin 5 brown	brown
2.3	Not used			
1.4	Shield connection			
2.4	Shield connection			



\* Phoenix Contact recommends using the INTERBUS standard cable to connect Fieldline Modular M12 or for local bus extension in combination with an IB IL 24 LSKIP (-PAC) terminal. For a detailed description of the assignment, please refer to the documentation for Fieldline Modular or the data sheet for the IB IL 24 LSKIP (-PAC) terminal.

## 5 Internal Basic Circuit Diagram

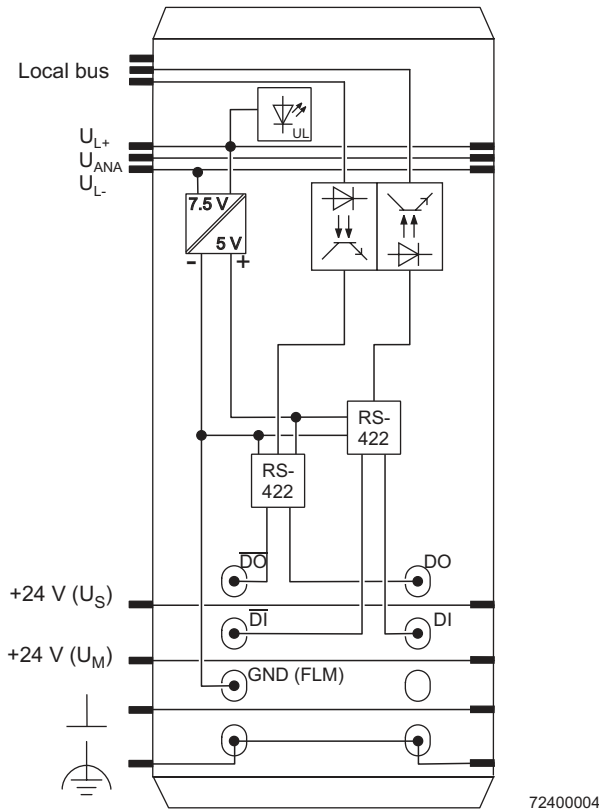





Figure 2 Internal wiring of the terminal points

Key:

-  DC/DC converter with electrical isolation
-  LED with details of the indicator designation (UL; see page 5)
-  Optocoupler
-  RS-422 interface

**i** Other symbols used are explained in the IL SYS INST UM E user manual or in the system manual for your bus system.

## 6 Installation Notes

Only use the branch terminal as the last terminal in an Inline station or as the last terminal of an Inline station row (see also page 8).

### In combination with Fieldline Modular M8:

- The maximum cable length within a branch is 40 m.

### In combination with Fieldline Modular M12:

- The maximum cable length within a branch is 20 m.

### In combination with Fieldline Modular M8 or M12:

- The maximum number of devices in a branch is 16.
- The maximum number of devices in an Inline station including the connected Fieldline Modular devices is 63. Only bus devices are counted (e.g., the branch terminal is not a bus device).

### In combination with a local bus extension terminal or with several local bus extension terminals:

- The total length of all cables between the first IB IL 24 FLM-PAC and last IB IL 24 LSKIP (-PAC) within an Inline station must not exceed a maximum of 20 m.

## 7 Connection Notes

### When integrating a Fieldline Modular M8 local bus in an Inline station:

To supply the FLM M8 system, insert a segment terminal with fuse and diagnostics directly before the IB IL 24 FLM-PAC terminal (see "Ordering Data" on page 2).

IB IL 24 SEG/F-D-PAC terminal point assignment

Terminal Point	Assignment	Conductor Color	Connection of M8
1.1, 2.1	+24 V U <sub>S</sub>	red	Pin 1
1.2, 2.2	+24 V U <sub>M</sub>		
1.3, 2.3	GND	blue	Pin 3
1.4, 2.4	FE		

### When integrating a Fieldline Modular M12 local bus in an Inline station:

Supply the supply voltage U<sub>LS</sub> separately at the first FLM device, if possible, in order to use the maximum permissible logic and sensor current of 4 A each for the FLM station.

## 8 Connecting the Cables

Example: Wiring for an FLM M8 system using the IB IL 24 SEG/F-D-PAC segment terminal

### Stripping the Outer Cable Sheath and Cables (Figure 3, Detail A)

- Strip approximately 100 mm off the outer cable sheath.
- Remove the protective foil.
- Shorten the braided shield by approximately 85 mm.
- Remove the felt and the protective foil of the wire pairs.
- Wind the filler litz wire around the shielding.
- Strip 8 mm off the wires.

### Connecting the Cables to the Terminal Points

- Release the spring by pressing with the screwdriver.
- Insert the cable in the corresponding terminal point.
- Secure the cable by removing the screwdriver.

### Connecting the Shield

- Open the shield connection (Figure 3, detail B).
- Insert the shield connection clamp according to the cable cross-section.
- Insert the cable (Figure 3, detail C).
- Close the shield connection (Figure 3, detail D).
- Tighten the screws on the shield connection with a screwdriver (Figure 3, detail E).

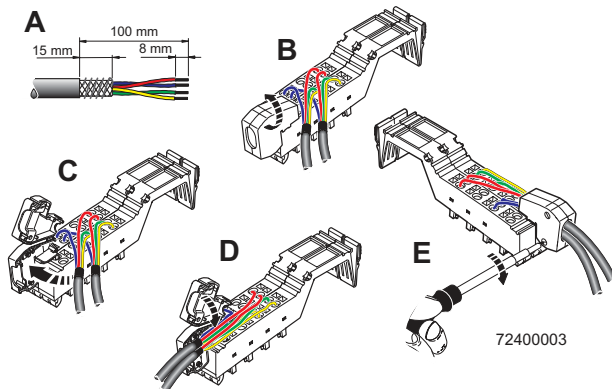

Figure 3 Example: Wiring of the IB IL 24 FLM-PAC and IB IL 24 SEG/F-D-PAC terminals

## 9 Connection Examples

### 9.1 Integration of a Fieldline Modular M8 Local Bus in an Inline Station

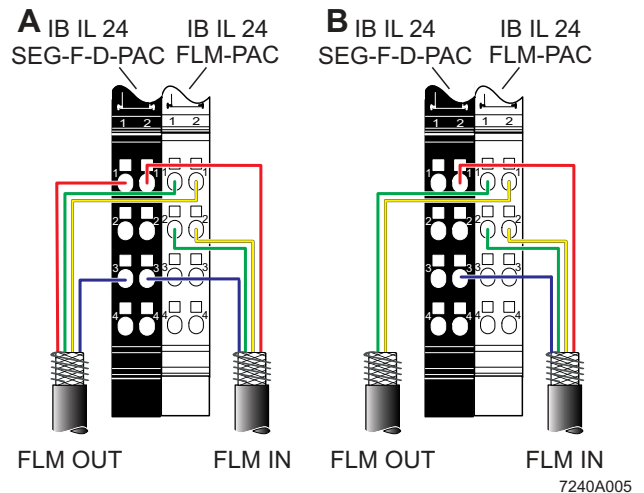

Figure 4 Typical connection of the Fieldline Modular M8 local bus

- A Supply voltage supplied from both sides
- B Supply voltage supplied from one side
- FLM OUT System cable forward line
- FLM IN System cable return line

**i** Please note when using the segment terminal that the maximum current consumption at  $U_S$  is 4 A.

9.2 Example: Integration of Fieldline Modular M8 Devices in an Inline Station

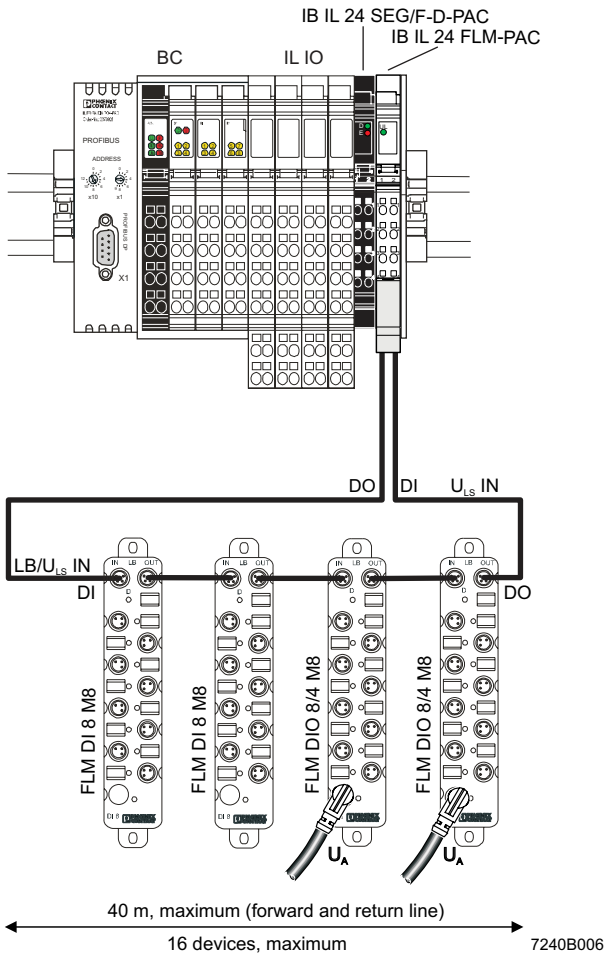

Figure 5 Example: Integration of Fieldline Modular M8 devices in an Inline station

Key

- BC Bus coupler
- IL IO Any Inline terminals

9.3 Example: Integration of Fieldline Modular M12 Devices in an Inline Station With Separate Supply From U<sub>LS</sub>

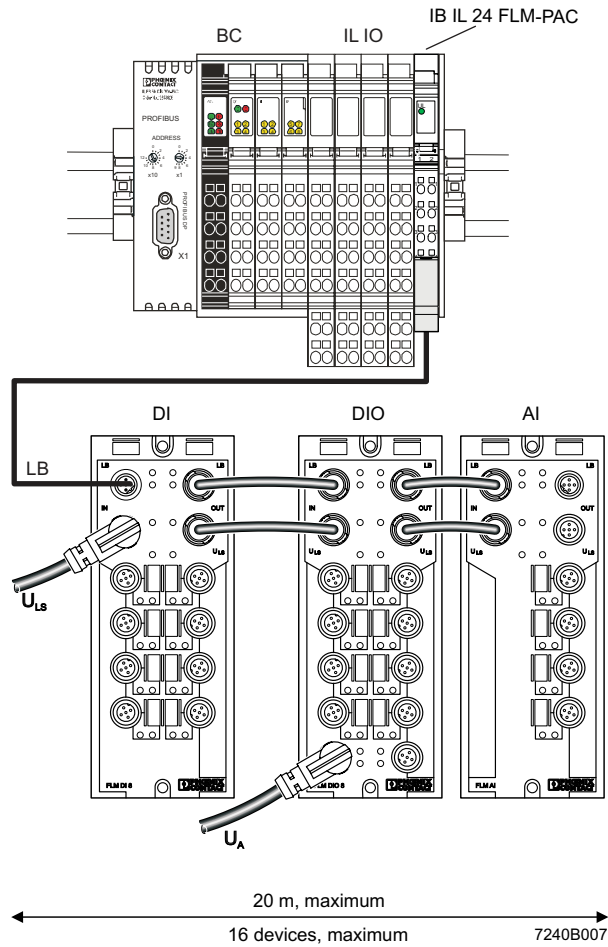

Figure 6 Example: Integration of Fieldline Modular M12 devices in an Inline station

Key

- BC Bus coupler
- IL IO Any Inline terminals



**9.4 Local Bus Extension in Combination With the IB IL 24 LSKIP (-PAC) Inline Local Bus Extension Terminal**

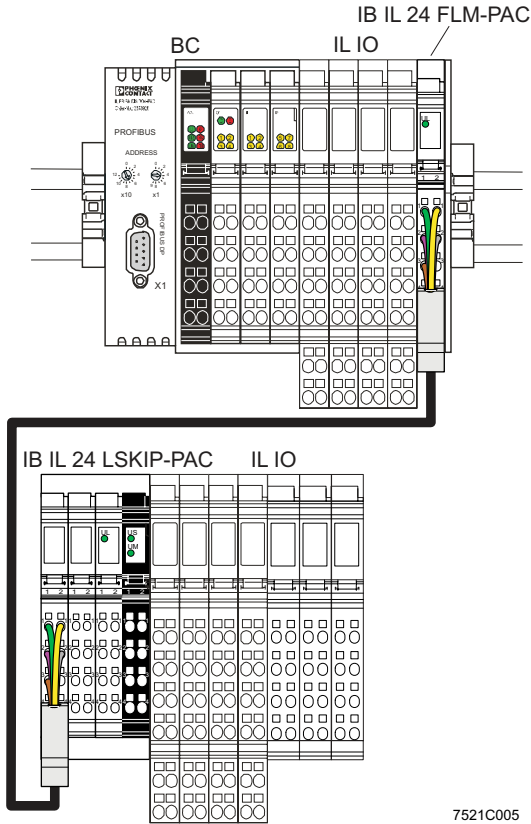

Figure 7 Example: Jumping between two rows within an Inline station

**Key**

- BC Bus coupler
- IL IO Any Inline terminals

A bus coupler opens the Inline station with any Inline terminals. To jump between two rows, insert an IB IL 24 FLM-PAC terminal at the end of the first row of the Inline station. The terminal operates in combination with the IB IL 24 LSKIP (-PAC) terminal, which creates the start of the next row of the Inline station. Supply the supply voltage for the Inline station at the IB IL 24 LSKIP (-PAC) terminal again. Any Inline terminals can be used within the Inline station.

**i** For the terminal point assignment of the IB IL 24 LSKIP (-PAC) terminal, please refer to the corresponding data sheet.

**Integration of Fieldline Modular Devices and Local Bus Extension**

If only the IB IL 24 FLM-PAC terminal is used, the local bus can be extended by several rows and the IB IL 24 FLM-PAC terminal inserted at the end of the last row in order to integrate Fieldline Modular devices.

If this is not sufficient for the application, the IB IL 24 FLM MULTI-PAC branch terminal can be used. This can be used multiple times and at any position within the Inline station (see Figure 8).

**i** When using the IB IL 24 FLM MULTI-PAC terminal, please observe the information in the corresponding data sheet.

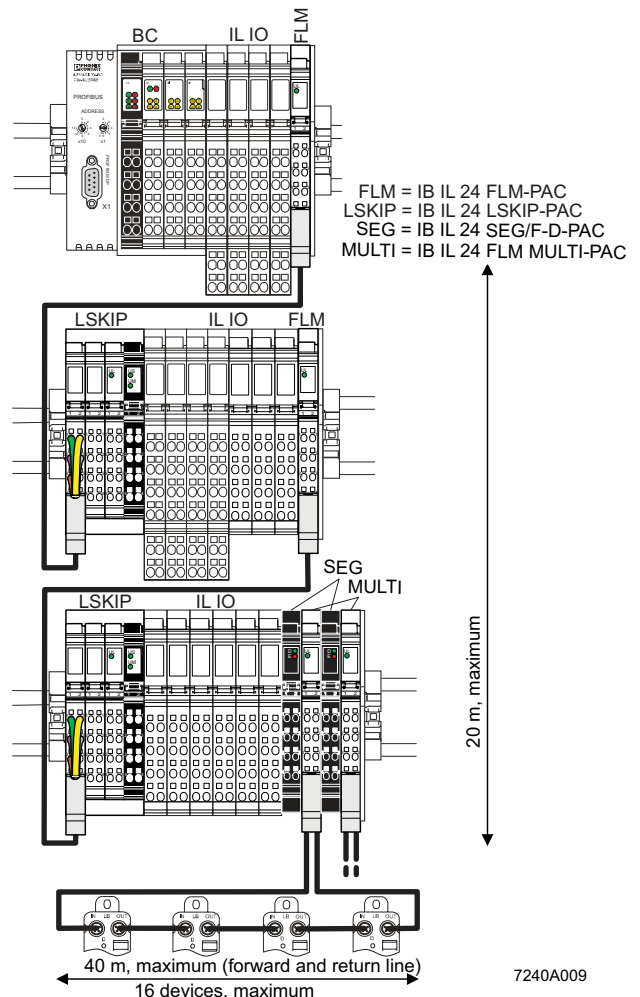

Figure 8 Example: Integration of Fieldline Modular devices and local bus extension