

APPROVED: _____
 DATE: _____ TITLE: _____

Rev	AWO #	Description	Date	Appr
-		RELEASED	6/17/05	
A		CHANGE TERMINAL	8/15/08	
B		REDRAWN	01/23/13	
C		UPDATE DRAWING	8/5/20	LH/LX

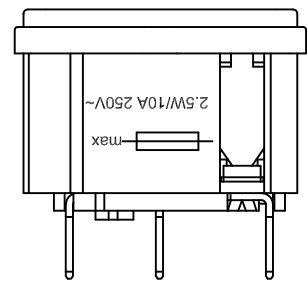
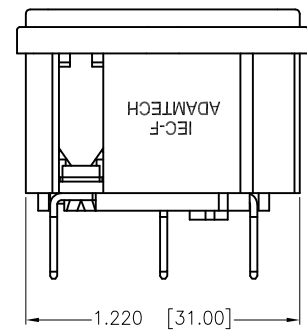
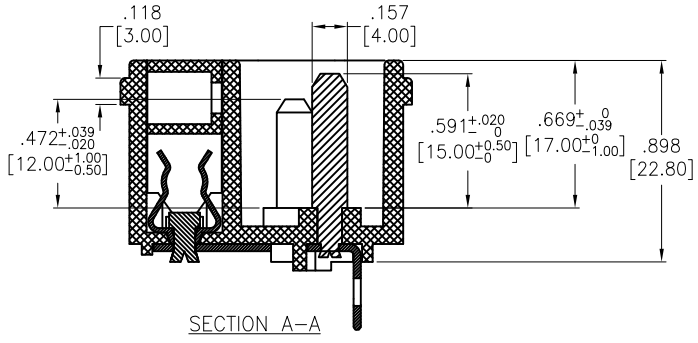
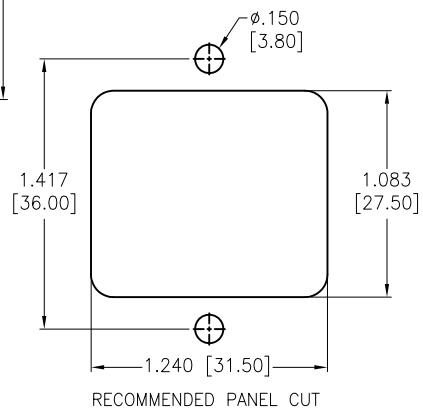
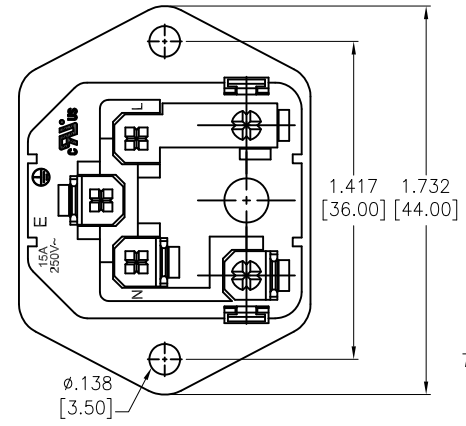
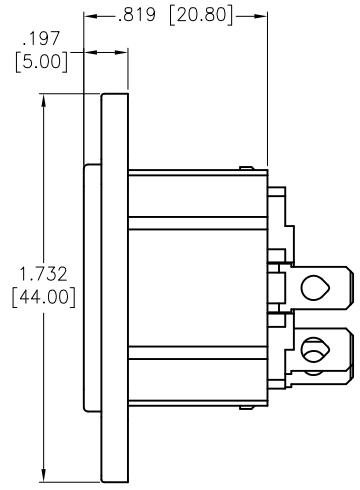
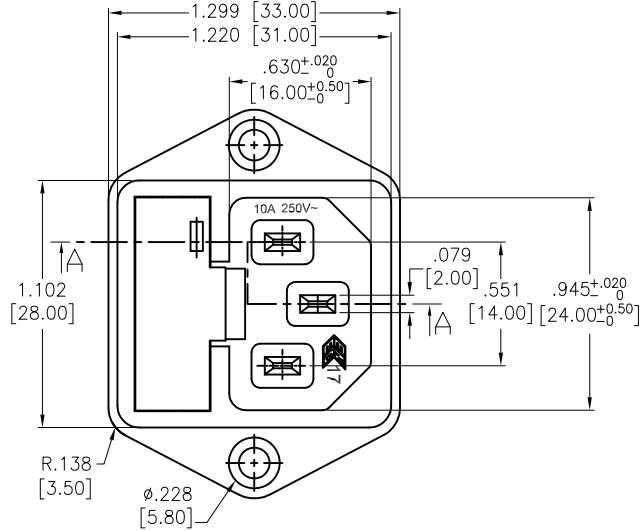

TERMINAL OPTIONS		
-1	-2	-3
.187 Q.C.	.250 Q.C.	.157 Solder

SPECIFICATIONS:

Material:
 Insulator: Nylon 66, rated UL 94V-0
 Insulator color: Black
 Contacts: Copper Alloy
 Plating:
 Tin over Copper underplate overall
 Electrical:
 Current rating: C-ULus: 15A @ 250V
 ENEC: 10A @ 250V
 Insulation resistance: 100 Mohms min @ 500 VDC
 Dielectric withstanding voltage: 3,000 VAC for 1 minute
 Environmental:
 Lead free, RoHS compliant



UNLESS OTHERWISE SPECIFIED
 ALL DIMENSIONS ARE INCHES [MM]
 TOLERANCES: EXCEPT AS NOTED
 INCHES HOLES
 .X ±.10 Ø.X ±.10
 .XX ±.020 Ø.XX ±.015
 .XXX ±.015 Ø.XXX ±.010

ADAM TECH
 INTERCONNECTS
 909 Rahway Avenue,
 Union, NJ 07083
 Phone: 908-687-5000
 Fax: 908-687-5710

APPROVALS		DATE
DRAWN	SS	6/17/05
CHECKED		
APPROVED		

TITLE IEC MALE INLET, SCREW ON PANEL MOUNT 5 x 20mm FUSE HOLDER		
SIZE X	PART NO. IEC-F-X	REV. C
REF: S00087C	SCALE: NTS	SHEET 1 OF 1