

SAW Filter 2250.0MHz
Part No: MP01137

Model: TA0700A
Rev No:1

A. MAXIMUM RATING:

1. Input Power Level: 10dBm
2. DC Voltage: 3V
3. Operating Temperature: -20°C to +70°C
4. Storage Temperature: -40°C to +85°C

B. ELECTRICAL CHARACTERISTICS:

Item	Unit	Min.	Typ.	Max.	Note
Center Frequency Fc	MHz	-	2250	-	-
Insertion Loss (2200 ~ 2300MHz) IL	dB	-	3.2	4.5	-
Amplitude Ripple (2200 ~ 2300MHz)	dB	-	1.9	3	-
VSWR (2200 ~ 2300MHz)		-	1.9	2.5	-
Attenuation (Reference level from 0dB)					
D.C. ~ 2160MHz	dB	25	28	-	-
2340 ~ 4000MHz	dB	25	32.5	-	-

C. MEASUREMENT CIRCUIT:

HP Network analyzer

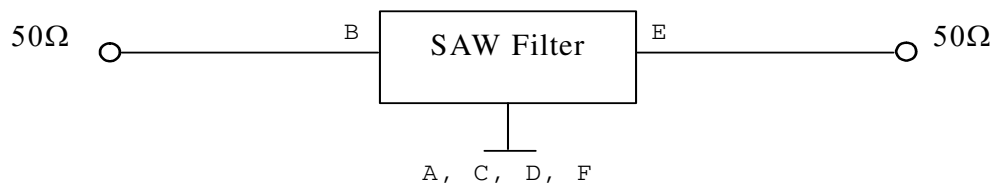

SAW Filter 2250.0MHz
Part No: MP01137

Model: TA0700A
Rev No:1

D. OUTLINE DRAWING:

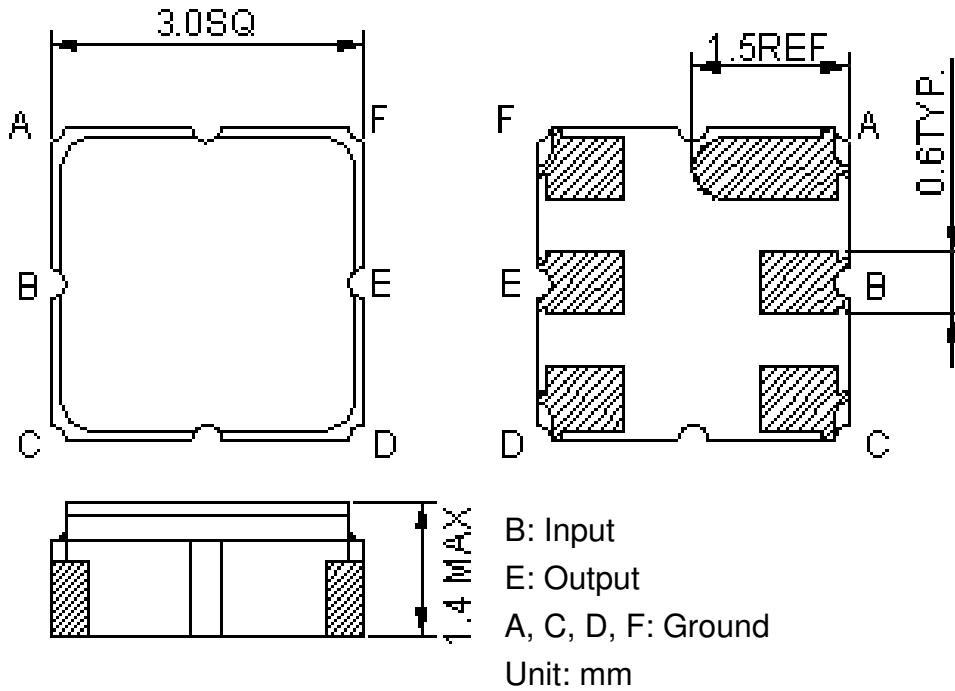

E. PCB FOOTPRINT:

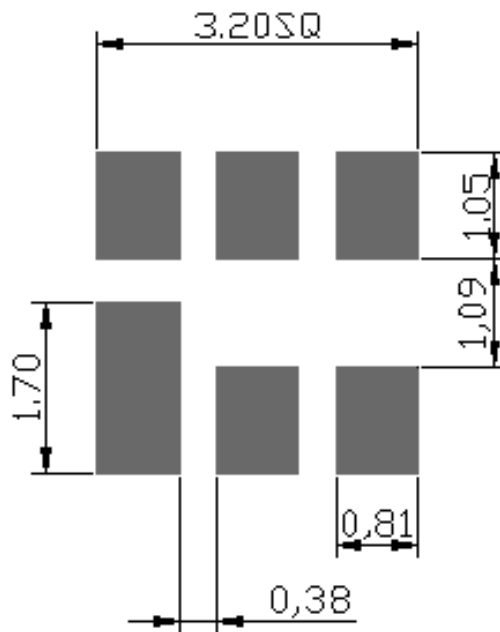

SAW Filter 2250.0MHz
Part No: MP01137

Model: TA0700A
Rev No:1

F. FREQUENCY CHARACTERISTICS:

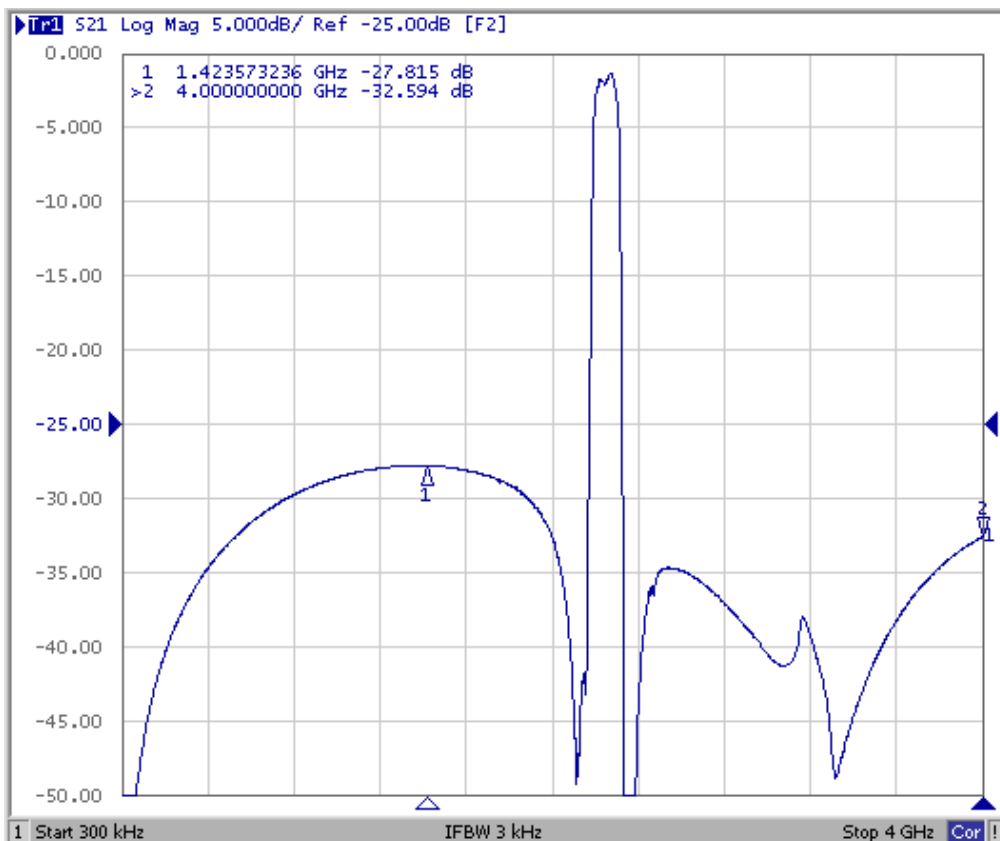
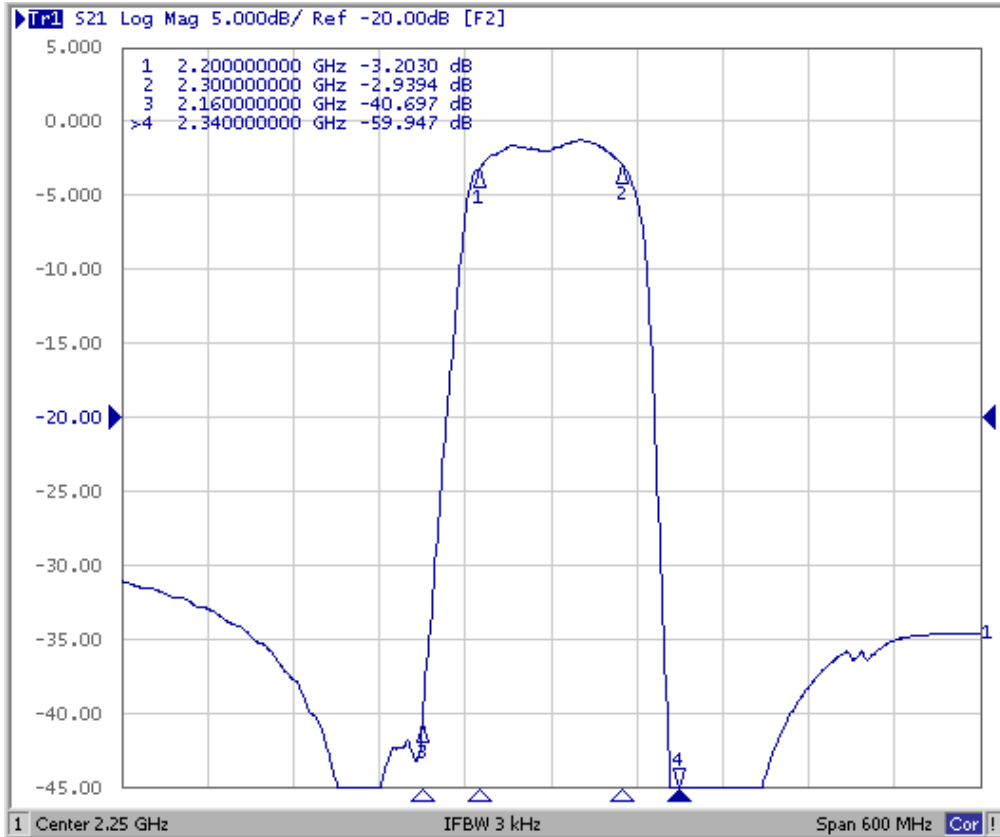

SAW Filter 2250.0MHz
Part No: MP01137

Model: TA0700A
Rev No:1

Reflection Functions

S11

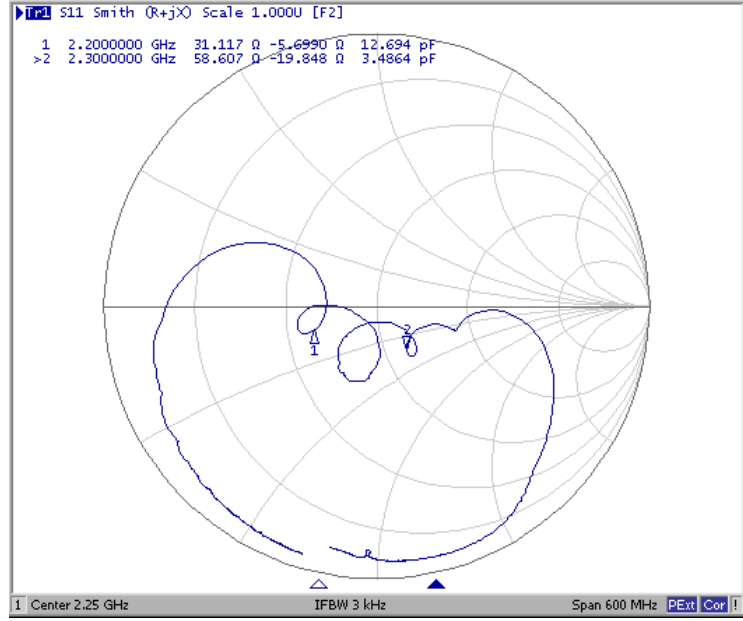
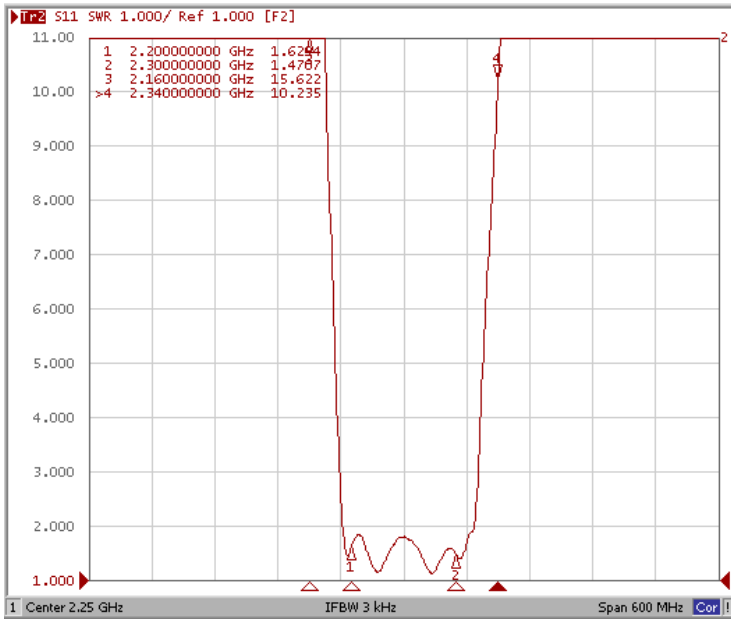

S22

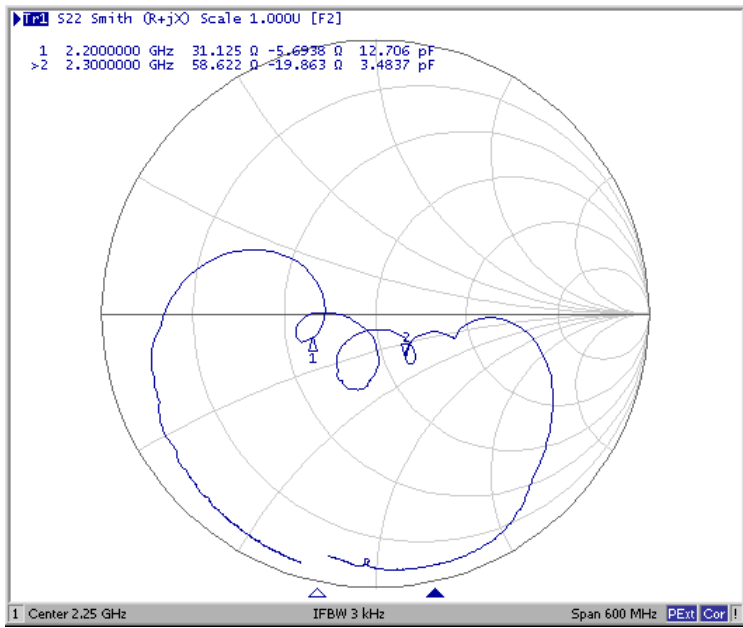
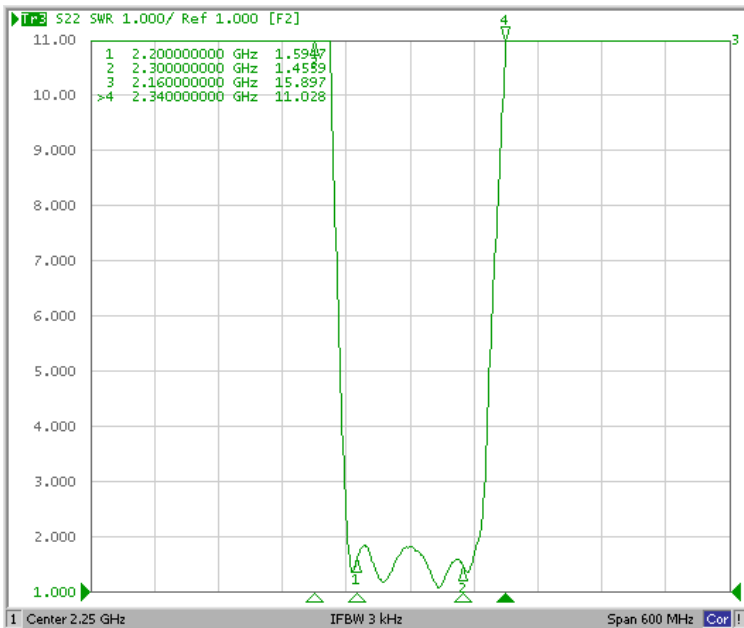

SAW Filter 2250.0MHz
Part No: MP01137

Model: TA0700A
Rev No:1

G. PACKING:

1. Reel Dimension (Reel Count: 7" = 1000; 13" = 3000)

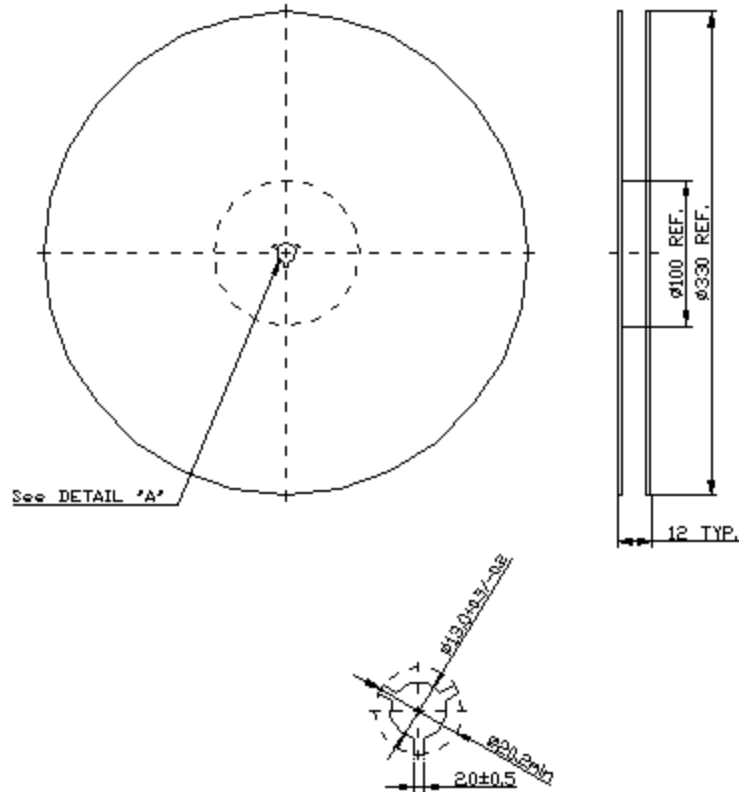

2. Tape Dimension

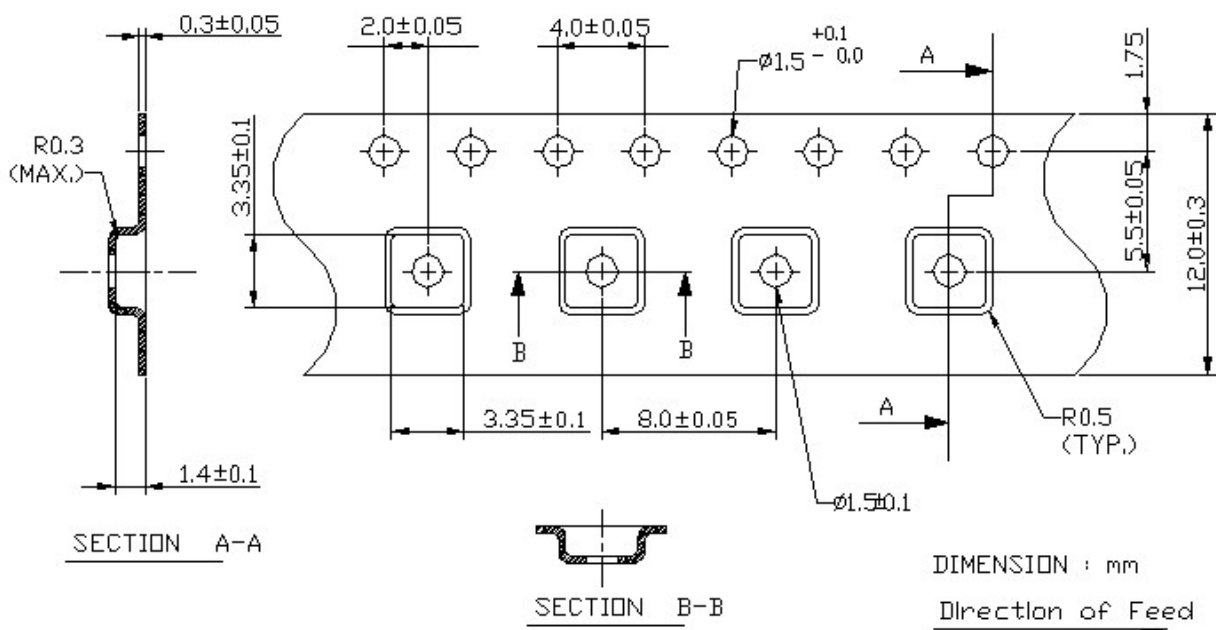

SAW Filter 2250.0MHz
Part No: MP01137

Model: TA0700A
Rev No:1

H. RECOMMENDED REFLOW PROFILE:

