



# 16-Bit DIGITAL-TO-ANALOG CONVERTER With Serial Data Interface

## FEATURES:

- SERIAL DIGITAL INTERFACE
- VOLTAGE OUTPUT:  $\pm 10V$ ,  $\pm 5V$ , 0 to  $+10V$
- $\pm 1$  LSB INTEGRAL LINEARITY
- 16-BIT MONOTONIC OVER TEMPERATURE
- PRECISION INTERNAL REFERENCE
- LOW NOISE:  $120nV/\sqrt{Hz}$  Including Reference
- 16-LEAD PLASTIC AND CERAMIC SKINNY DIP AND PLASTIC SO PACKAGES

## DESCRIPTION

The DAC714 is a complete monolithic digital-to-analog (D/A) converter including a  $+10V$  temperature compensated reference, current-to-voltage amplifier, a high-speed synchronous serial interface, a serial output which allows cascading multiple converters, and an asynchronous clear function which immediately sets the output voltage to midscale.

The output voltage range is  $\pm 10V$ ,  $\pm 5V$ , or 0 to  $+10V$  while operating from  $\pm 12V$  or  $\pm 15V$  supplies. The gain and bipolar offset adjustments are designed so that they can be set via external potentiometers or external D/A converters. The output amplifier is protected against short circuit to ground.

The 16-pin DAC714 is available in a plastic 0.3" DIP, ceramic 0.3" CERDIP, and wide-body plastic SO package. The DAC714P, U, HB, and HC are specified over the  $-40^{\circ}C$  to  $+85^{\circ}C$  temperature range while the DAC714HL is specified over the  $0^{\circ}C$  to  $+70^{\circ}C$  range.

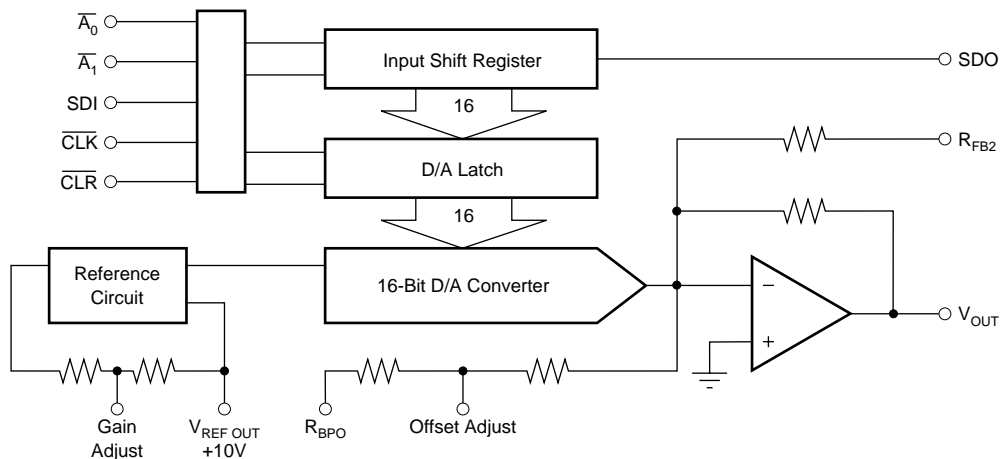

Please be aware that an important notice concerning availability, standard warranty, and use in critical applications of Texas Instruments semiconductor products and disclaimers thereto appears at the end of this data sheet.

All trademarks are the property of their respective owners.

## ABSOLUTE MAXIMUM RATINGS<sup>(1)</sup>

+V <sub>CC</sub> to Common	0V to +17V
-V <sub>CC</sub> to Common	0V to -17V
+V <sub>CC</sub> to -V <sub>CC</sub>	34V
ACOM to DCOM	±0.5V
Digital Inputs to Common	-1V to (V <sub>CC</sub> - 0.7V)
External Voltage Applied to BPO and Range Resistors	±V <sub>CC</sub>
V <sub>REF OUT</sub>	Indefinite Short to Common
V <sub>OUT</sub>	Indefinite Short to Common
SDO	Indefinite Short to Common
Power Dissipation	750mW
Storage Temperature	-60°C to +150°C
Lead Temperature (soldering, 10s)	+300°C

NOTE: (1) Stresses above those listed under *Absolute Maximum Ratings* may cause permanent damage to the device. Exposure to absolute maximum conditions for extended periods may affect device reliability.

## PACKAGE/ORDERING INFORMATION

For the most current package and ordering information, see the Package Option Addendum at the end of this document, or see the TI website at [www.ti.com](http://www.ti.com).

## PIN CONFIGURATION

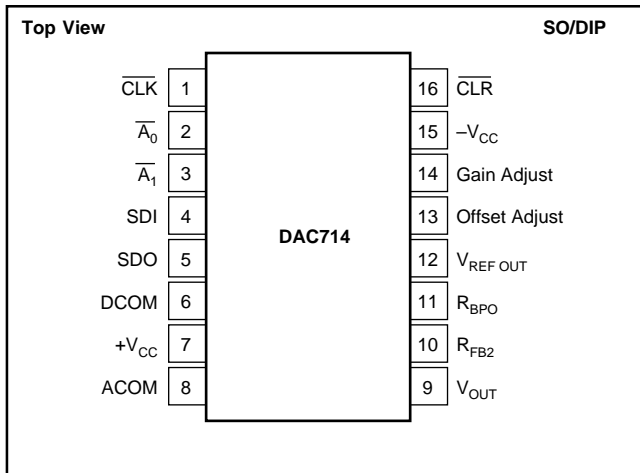

## ELECTROSTATIC DISCHARGE SENSITIVITY

This integrated circuit can be damaged by ESD. Texas Instruments recommends that all integrated circuits be handled with appropriate precautions. Failure to observe proper handling and installation procedures can cause damage.

ESD damage can range from subtle performance degradation to complete device failure. Precision integrated circuits may be more susceptible to damage because very small parametric changes could cause the device not to meet its published specifications.

## PIN DESCRIPTIONS

PIN	LABEL	DESCRIPTION
1	CLK	Serial Data Clock
2	A <sub>0</sub>	Enable for Input Register (Active Low)
3	A <sub>1</sub>	Enable for D/A Latch (Active Low)
4	SDI	Serial Data Input
5	SDO	Serial Data Output
6	DCOM	Digital Ground
7	+V <sub>CC</sub>	Positive Power Supply
8	ACOM	Analog Ground
9	V <sub>OUT</sub>	D/A Output
10	R <sub>FB2</sub>	±10V Range Feedback Output
11	R <sub>BPO</sub>	Bipolar Offset
12	V <sub>REF OUT</sub>	Voltage Reference Output
13	Offset Adjust	Offset Adjust
14	Gain Adjust	Gain Adjust
15	-V <sub>CC</sub>	Negative Power Supply
16	CLR	Clear

# ELECTRICAL CHARACTERISTICS

At  $T_A = +25^\circ\text{C}$ ,  $+V_{CC} = +12\text{V}$  and  $+15\text{V}$ ,  $-V_{CC} = -12\text{V}$ , and  $-15\text{V}$ , unless otherwise noted.

PARAMETER	DAC714P, U			DAC714HB			DAC714HC			DAC714HL			UNITS
	MIN	TYP	MAX	MIN	TYP	MAX	MIN	TYP	MAX	MIN	TYP	MAX	
<b>TRANSFER CHARACTERISTICS</b>													
<b>ACCURACY</b>													
Linearity Error			$\pm 4$			$\pm 2$			$\pm 1$			$\pm 1$	LSB
$T_{\text{MIN}}$ to $T_{\text{MAX}}$			$\pm 8$			$\pm 4$			$\pm 2$			$\pm 2$	LSB
Differential Linearity Error			$\pm 4$			$\pm 2$			$\pm 1$			$\pm 1$	LSB
$T_{\text{MIN}}$ to $T_{\text{MAX}}$			$\pm 8$			$\pm 4$			$\pm 2$			$\pm 1$	LSB
Monotonicity	14			15			16			16			Bits
Monotonicity Over Spec Temp Range	13			14			15			16			Bits
Gain Error <sup>(3)</sup>			$\pm 0.1$			$\pm 0.1$			$\pm 0.1$			$\pm 0.1$	%
$T_{\text{MIN}}$ to $T_{\text{MAX}}$			$\pm 0.25$			$\pm 0.25$			$\pm 0.25$			$\pm 0.25$	%
Unipolar/Bipolar Zero Error <sup>(3)</sup>			$\pm 0.1$			$\pm 0.1$			$\pm 0.1$			$\pm 0.1$	% of FSR <sup>(2)</sup>
$T_{\text{MIN}}$ to $T_{\text{MAX}}$			$\pm 0.2$			$\pm 0.2$			$\pm 0.2$			$\pm 0.2$	% of FSR
Power Supply Sensitivity of Gain			$\pm 0.003$			$\pm 0.003$			$\pm 0.003$			$\pm 0.003$	%FSR/% $V_{CC}$
			$\pm 30$			$\pm 30$			$\pm 30$			$\pm 30$	ppm FSR/% $V_{CC}$
<b>DYNAMIC PERFORMANCE</b>													
Settling Time (to $\pm 0.003\%$ FSR, $5\text{k}\Omega$    $500\text{pF}$ Load) <sup>(4)</sup>													
20V Output Step		6	10		6	10		6	10		6	10	$\mu\text{s}$
1LSB Output Step <sup>(5)</sup>		4			4			4			4		$\mu\text{s}$
Output Slew Rate		10			10			10			10		$\text{V}/\mu\text{s}$
Total Harmonic Distortion													
0dB, 1001Hz, $f_s = 100\text{kHz}$		0.005			0.005			0.005			0.005		%
-20dB, 1001Hz, $f_s = 100\text{kHz}$		0.03			0.03			0.03			0.03		%
-60dB, 1001Hz, $f_s = 100\text{kHz}$		3.0			3.0			3.0			3.0		%
SINAD: 1001Hz, $f_s = 100\text{kHz}$		87			87			87			87		dB
Digital Feedthrough <sup>(5)</sup>		2			2			2			2		nV-s
Digital-to-Analog Glitch Impulse <sup>(5)</sup>		15			15			15			15		nV-s
Output Noise Voltage (includes reference)		120			120			120			120		$\text{nV}/\sqrt{\text{Hz}}$
<b>ANALOG OUTPUT</b>													
Output Voltage Range													
$+V_{CC}$ , $-V_{CC} = \pm 11.4\text{V}$	$\pm 10$			$\pm 10$			$\pm 10$			$\pm 10$			V
Output Current	$\pm 5$			$\pm 5$			$\pm 5$			$\pm 5$			mA
Output Impedance		0.1			0.1			0.1			0.1		$\Omega$
Short Circuit to ACOM Duration		Indefinite			Indefinite			Indefinite			Indefinite		
<b>REFERENCE VOLTAGE</b>													
Voltage	+9.975	+10.000	+10.025	+9.975	+10.000	+10.025	+9.975	+10.000	+10.025	+9.975	+10.000	+10.025	V
$T_{\text{MIN}}$ to $T_{\text{MAX}}$	+9.960		+10.040	+9.960		+10.040	+9.960		+10.040	+9.960		+10.040	V
Output Resistance		1			1			1			1		$\Omega$
Source Current	2			2			2			2			mA
Short Circuit to ACOM Duration		Indefinite			Indefinite			Indefinite			Indefinite		
<b>INTERFACE</b>													
<b>RESOLUTION</b>													
DIGITAL INPUTS		16			16			16			16		Bits
Serial Data Input Code													
Logic Levels <sup>(1)</sup>													
$V_{\text{IH}}$	+2.0		( $V_{CC} - 1.4$ )	+2.0		( $V_{CC} - 1.4$ )	+2.0		( $V_{CC} - 1.4$ )	+2.0		( $V_{CC} - 1.4$ )	V
$V_{\text{IL}}$	0		+0.8	0		+0.8	0		+0.8	0		+0.8	V
$I_{\text{IH}}$ ( $V_{\text{I}} = +2.7\text{V}$ )			$\pm 10$			$\pm 10$			$\pm 10$			$\pm 10$	$\mu\text{A}$
$I_{\text{IL}}$ ( $V_{\text{I}} = +0.4\text{V}$ )			$\pm 10$			$\pm 10$			$\pm 10$			$\pm 10$	$\mu\text{A}$
<b>DIGITAL OUTPUT</b>													
Serial Data													
$V_{\text{OL}}$ ( $I_{\text{SINK}} = 1.6\text{mA}$ )	0		+0.4	0		+0.4	0		+0.4	0		+0.4	V
$V_{\text{OH}}$ ( $I_{\text{SOURCE}} = 500\mu\text{A}$ ), $T_{\text{MIN}}$ to $T_{\text{MAX}}$	+2.4		+5	+2.4		+5	+2.4		+5	+2.4		+5	V
<b>POWER SUPPLY REQUIREMENTS</b>													
Voltage													
$+V_{CC}$	+11.4	+15	+16.5	+11.4	+15	+16.5	+11.4	+15	+16.5	+11.4	+15	+16.5	V
$-V_{CC}$	-11.4	-15	-16.5	-11.4	-15	-16.5	-11.4	-15	-16.5	-11.4	-15	-16.5	V
Current (No Load, $\pm 15\text{V}$ Supplies) <sup>(6)</sup>													
$+V_{CC}$		13	16		13	16		13	16		13	16	mA
$-V_{CC}$		22	26		22	26		22	26		22	26	mA
Power Dissipation <sup>(7)</sup>			625			625			625			625	mW
<b>TEMPERATURE RANGES</b>													
Specification													
All Grades	-40		+85	-40		+85	-40		+85	0		+70	$^\circ\text{C}$
Storage	-60		+150	-60		+150	-60		+150	-60		+150	$^\circ\text{C}$
Thermal Coefficient, $\theta_{\text{JA}}$		75			75			75			75		$^\circ\text{C}/\text{W}$

NOTES: (1) Digital inputs are TTL and +5V CMOS compatible over the specification temperature range. (2) FSR means Full Scale Range. For example, for  $\pm 10\text{V}$  output,  $\text{FSR} = 20\text{V}$ . (3) Errors externally adjustable to zero. (4) Maximum represents the  $3\sigma$  limit. Not 100% tested for this parameter. (5) For the worst-case Binary Two's Complement code changes:  $\text{FFFF}_{\text{H}}$  to  $0000_{\text{H}}$  and  $0000_{\text{H}}$  to  $\text{FFFF}_{\text{H}}$ . (6) During power supply turn on, the transient supply current may approach  $3\times$  the maximum quiescent specification. (7) Typical (i.e. rated) supply voltages times maximum currents.

## TIMING SPECIFICATIONS

$T_A = -40^\circ\text{C}$  to  $+85^\circ\text{C}$ ,  $+V_{CC} = +12\text{V}$  or  $+15\text{V}$ ,  $-V_{CC} = -12\text{V}$  or  $-15\text{V}$ .

SYMBOL	PARAMETER	MIN	MAX	UNITS
$t_{CLK}$	Data Clock Period	100		ns
$t_{CL}$	Clock LOW	50		ns
$t_{CH}$	Clock HIGH	50		ns
$t_{A0S}$	Setup Time for $\overline{A_0}$	50		ns
$t_{A1S}$	Setup Time for $\overline{A_1}$	50		ns
$t_{A0H}$	Hold Time for $\overline{A_0}$	0		ns
$t_{A1H}$	Hold Time for $\overline{A_1}$	0		ns
$t_{DS}$	Setup Time for DATA	50		ns
$t_{DH}$	Hold Time for DATA	10		ns
$t_{DSOP}$	Output Propagation Delay		140	ns
$t_{CP}$	Clear Pulsewidth	200		ns

## TRUTH TABLE

$\overline{A_0}$	$\overline{A_1}$	$\overline{CLK}$	$\overline{CLR}$	DESCRIPTION
0	1	1 → 0 → 1	1	Shift Serial Data into SDI
1	0	1 → 0 → 1	1	Load D/A Latch
1	1	1 → 0 → 1	1	No Change
0	0	1 → 0 → 1	1	Two Wire Operation <sup>(1)</sup>
X	X	1	1	No Change
X	X	X	0	Reset D/A Latch

NOTES: X = Don't Care. (1) All digital input changes will appear at the output.

## TIMING DIAGRAMS

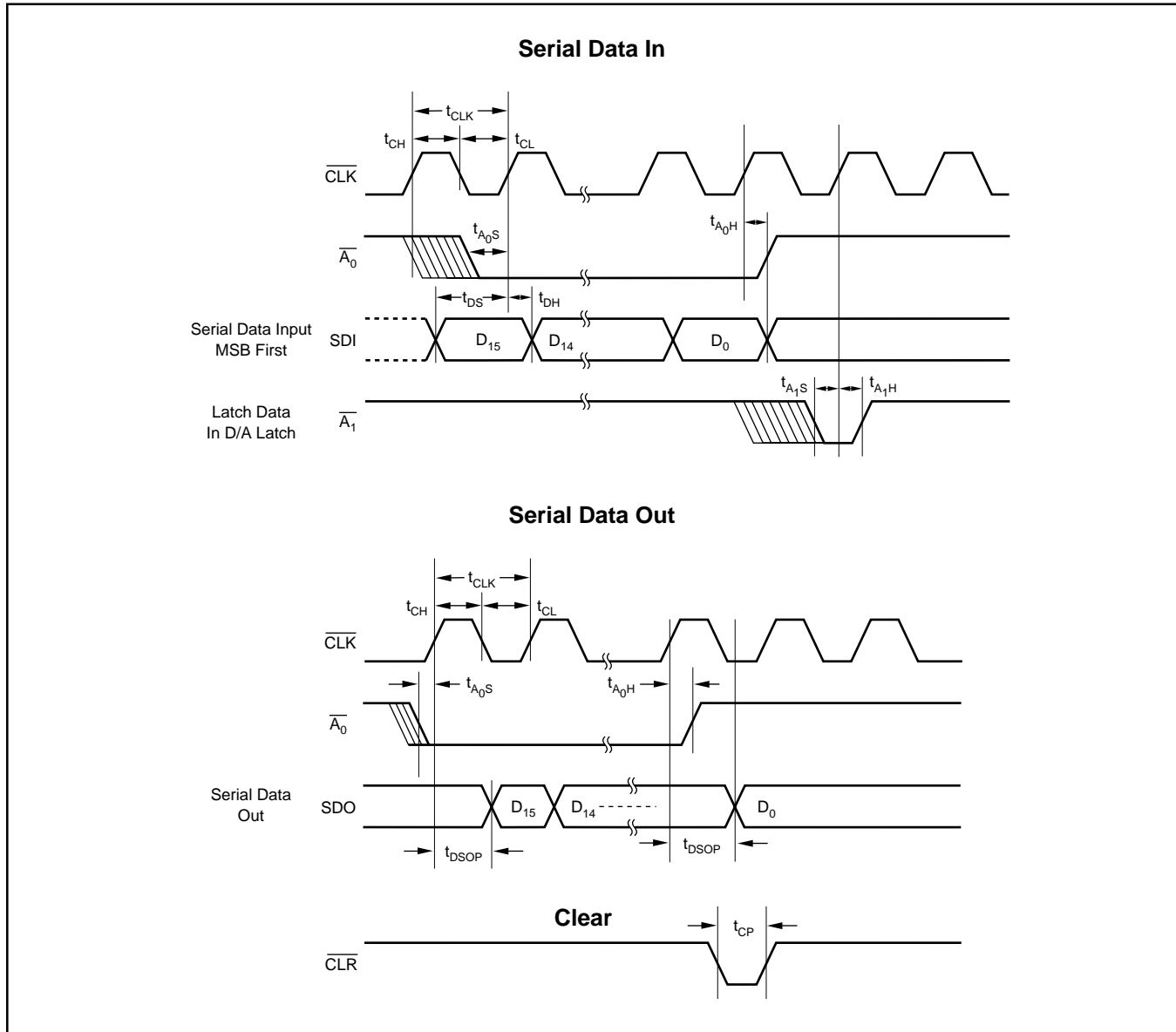

# TYPICAL CHARACTERISTICS

At  $T_A = +25^\circ\text{C}$ ,  $V_{CC} = \pm 15\text{V}$ , unless otherwise noted.

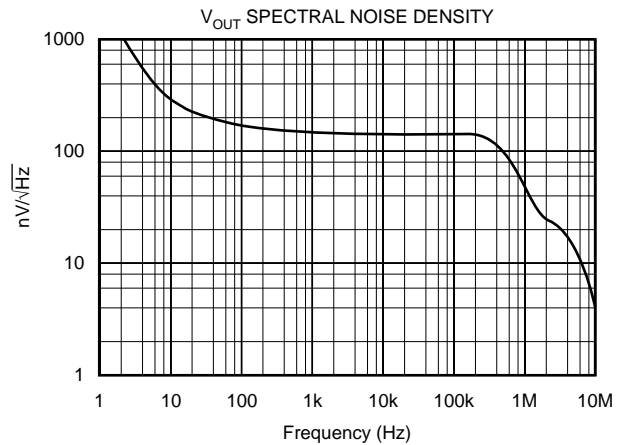
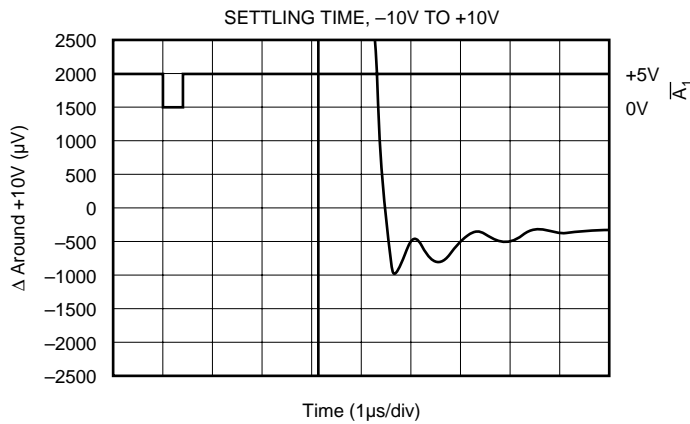
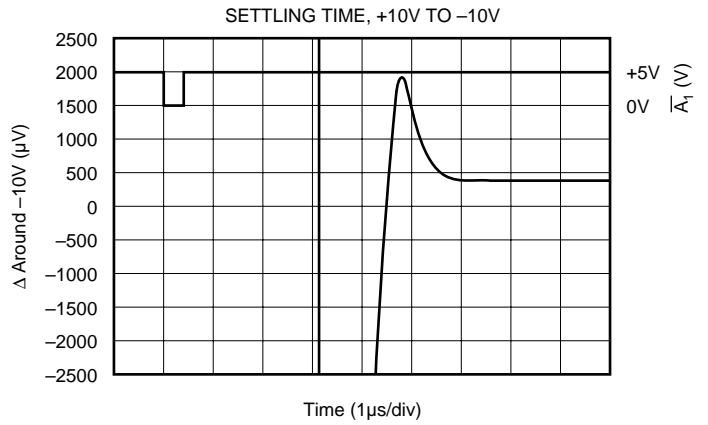
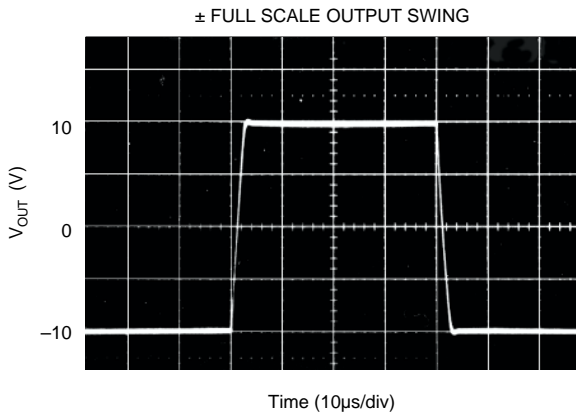
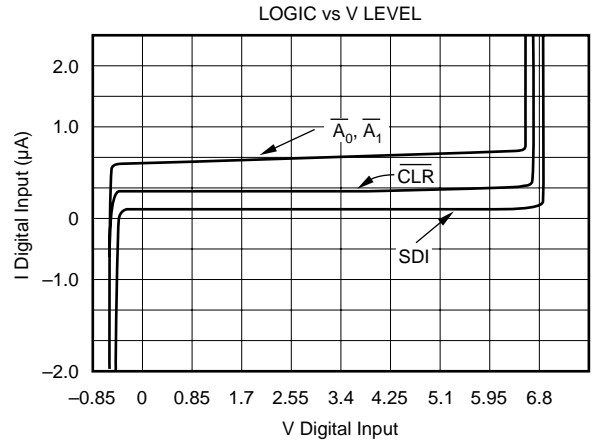
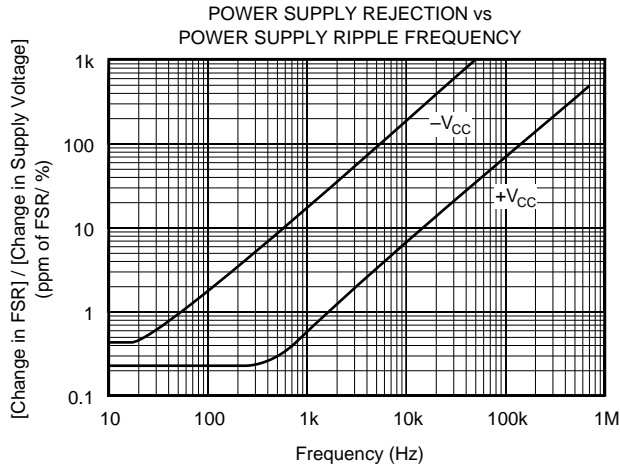

# DISCUSSION OF SPECIFICATIONS

## LINEARITY ERROR

Linearity error is defined as the deviation of the analog output from a straight line drawn between the end points of the transfer characteristic.

## DIFFERENTIAL LINEARITY ERROR

Differential linearity error (DLE) is the deviation from 1LSB of an output change from one adjacent state to the next. A DLE specification of  $\pm 1/2\text{LSB}$  means that the output step size can range from  $1/2\text{LSB}$  to  $3/2\text{LSB}$  when the digital input code changes from one code word to the adjacent code word. If the DLE is more positive than  $-1\text{LSB}$ , the D/A is said to be monotonic.

## MONOTONICITY

A D/A converter is monotonic if the output either increases or remains the same for increasing digital input values. Monotonicity of the C and L grades is assured over the specification temperature range to 16 bits.

## SETTLING TIME

Settling time is the total time (including slew time) for the D/A output to settle to within an error band around its final value after a change in input. Settling times are specified to within  $\pm 0.003\%$  of Full Scale Range (FSR) for an output step change of 20V and 1LSB. The 1LSB change is measured at the Major Carry ( $\text{FFFF}_{\text{H}}$  to  $0000_{\text{H}}$ , and  $0000_{\text{H}}$  to  $\text{FFFF}_{\text{H}}$ ; BTC codes), the input transition at which worst-case settling time occurs.

## TOTAL HARMONIC DISTORTION

Total harmonic distortion is defined as the ratio of the square root of the sum of the squares of the values of the harmonics to the value of the fundamental frequency. It is expressed in % of the fundamental frequency amplitude at sampling rate  $f_s$ .

## SIGNAL-TO-NOISE AND DISTORTION RATIO (SINAD)

SINAD includes all the harmonic and outstanding spurious components in the definition of output noise power in addition to quantizing and internal random noise power. SINAD is expressed in dB at a specified input frequency and sampling rate,  $f_s$ .

## DIGITAL-TO-ANALOG GLITCH IMPULSE

The amount of charge injected into the analog output from the digital inputs when the inputs change state. It is measured at half scale at the input codes where as many as possible switches change state—from  $0000_{\text{H}}$  to  $\text{FFFF}_{\text{H}}$ .

## DIGITAL FEEDTHROUGH

When the A/D is not selected, high frequency logic activity on the digital inputs is coupled through the device and shows up as output noise. This noise is digital feedthrough.

## OPERATION

The DAC714 is a monolithic integrated-circuit 16-bit D/A converter complete with 16-bit D/A switches and ladder network, voltage reference, output amplifier and a serial interface.

## INTERFACE LOGIC

The DAC714 has double-buffered data latches. The input data latch holds a 16-bit data word before loading it into the second latch, the D/A latch. This double-buffered organization permits simultaneous update of several D/A converters. All digital control inputs are active low. Refer to the block diagram shown in Figure 1.

All latches are level-triggered. Data present when the enable inputs are logic "0" will enter the latch. When the enable inputs return to logic "1", the data is latched.

The  $\overline{\text{CLR}}$  input resets both the input latch and the D/A latch to  $0000_{\text{H}}$  (midscale).

## LOGIC INPUT COMPATIBILITY

The DAC714 digital inputs are TTL compatible (1.4V switching level), low leakage, and high impedance. Thus, the inputs are suitable for being driven by any type of 5V logic family, such as CMOS. An equivalent circuit for the digital inputs is shown in Figure 2.

The inputs will float to logic "0" if left unconnected. It is recommended that any unused inputs be connected to DCOM to improve noise immunity.

Digital inputs remain high impedance when power is off.

## INPUT CODING

The DAC714 is designed to accept binary two's complement (BTC) input codes with the MSB first which are compatible with bipolar analog output operation. For this configuration, a digital input of  $7\text{FFF}_{\text{H}}$  produces a plus full scale output,  $8000_{\text{H}}$  produces a minus full scale output, and  $0000_{\text{H}}$  produces bipolar zero output.

## INTERNAL REFERENCE

The DAC714 contains a +10V reference. The reference output may be used to drive external loads, sourcing up to 2mA. The load current should be constant; otherwise, the gain and bipolar offset of the converter will vary.

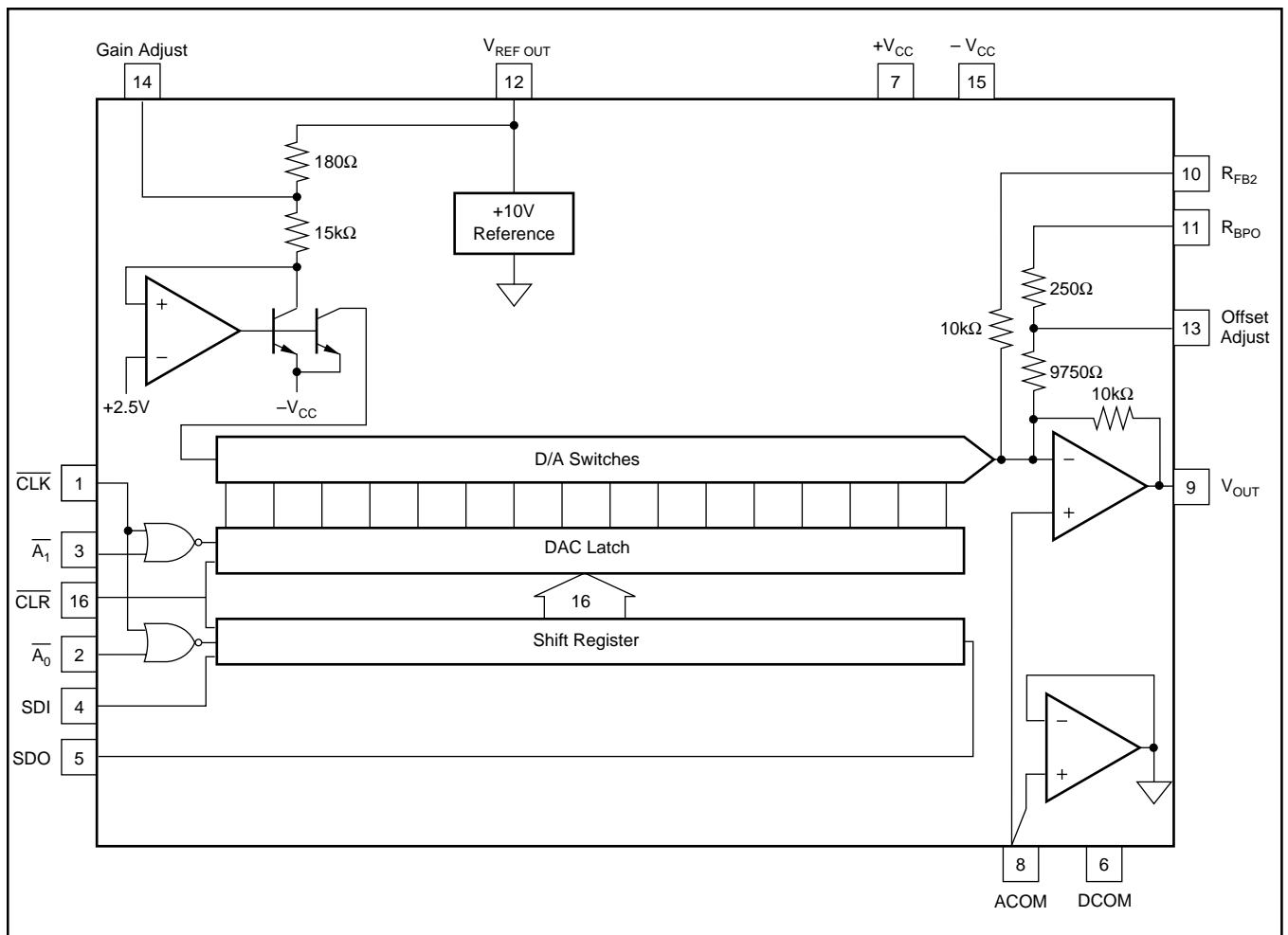

FIGURE 1. DAC714 Block Diagram.

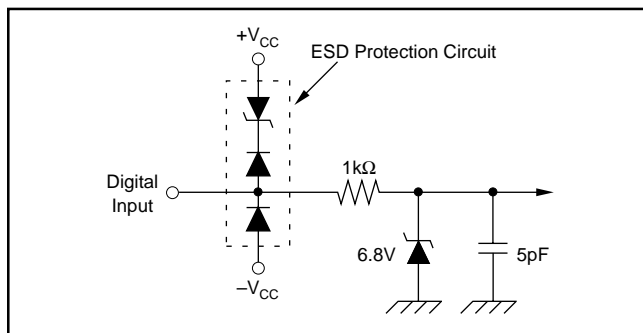

FIGURE 2. Equivalent Circuit of Digital Inputs.

### OUTPUT VOLTAGE SWING

The output amplifier of the DAC714 is designed to achieve a  $\pm 10V$  output range while operating on  $\pm 11.4V$  or higher power supplies.

### GAIN AND OFFSET ADJUSTMENTS

Figure 3 illustrates the relationship of offset and gain adjustments for a bipolar connected D/A converter. Offset should be adjusted first to avoid interaction of adjustments. See Table I for calibration values and codes. These adjustments have a minimum range of  $\pm 0.3\%$ .

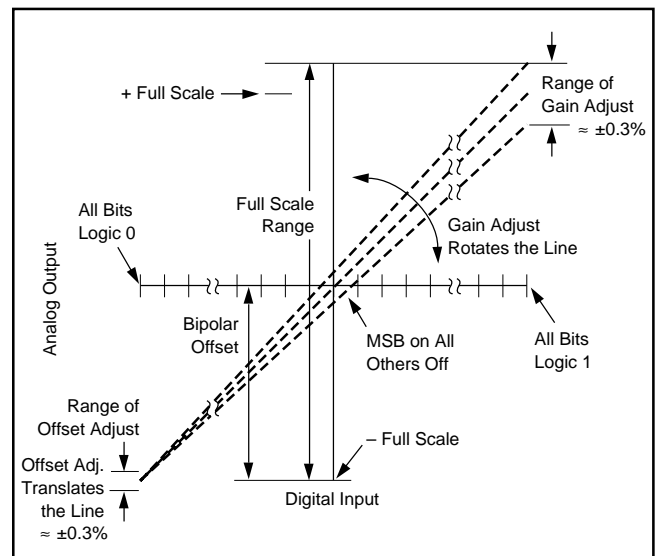

FIGURE 3. Relationship of Offset and Gain Adjustments.

### Offset Adjustment

Apply the digital input code,  $8000_H$ , that produces the maximum negative output voltage and adjust the offset potentiometer or the offset adjust D/A converter for  $-10V$  (or  $0V$  unipolar).

DAC714 CALIBRATION VALUES			
DIGITAL INPUT CODE BINARY TWO'S COMPLEMENT, BTC	ANALOG OUTPUT (V)		DESCRIPTION
	BIPOLAR 20V RANGE	UNIPOLAR 10V RANGE	
7FFF <sub>H</sub>	+9.999695	+9.999847	+ Full Scale -1LSB
4000 <sub>H</sub>	+5.000000	+7.500000	3/4 Scale
0001 <sub>H</sub>	+0.000305	+5.000153	BPZ + 1LSB
0000 <sub>H</sub>	0.000000	+5.000000	Bipolar Zero (BPZ)
FFFF <sub>H</sub>	-0.000305	+4.999847	BPZ - 1LSB
C000 <sub>H</sub>	-5.000000	+2.500000	1/4 Scale
8000 <sub>H</sub>	-10.000000	0.000000	Minus Full Scale

TABLE I. Digital Input and Analog Output Voltage Calibration Values.

### Gain Adjustment

Apply the digital input that gives the maximum positive voltage output. Adjust the gain potentiometer or the gain adjust D/A converter for this positive full scale voltage.

## INSTALLATION

### GENERAL CONSIDERATIONS

Due to the high accuracy of the DAC714 system design, problems such as grounding and contact resistance become very important. A 16-bit converter with a 20V full-scale range has a 1LSB value of 305 $\mu$ V. With a load current of 5mA, series wiring and connector resistance of only 60m $\Omega$  will cause a voltage drop of 300 $\mu$ V. To understand what this means in terms of a system layout, the resistivity of a typical 1 ounce copper-clad printed circuit board is 1/2 m $\Omega$  per square. For a 5mA load, a 10 milliinch wide printed circuit conductor 60 milliinches long will result in a voltage drop of 150 $\mu$ V.

The analog output of DAC714 has an LSB size of 305 $\mu$ V (-96dB) in the bipolar mode. The rms noise floor of the D/A should remain below this level in the frequency range of interest. The DAC714's output noise spectral density (which includes the noise contributed by the internal reference,) is shown in the Typical Characteristic section.

Wiring to high-resolution D/A converters should be routed to provide optimum isolation from sources of RFI and EMI. The key to elimination of RF radiation or pickup is small loop area. Signal leads and their return conductors should be kept close together such that they present a small capture cross-section for any external field. Wire-wrap construction is not recommended.

### POWER SUPPLY AND REFERENCE CONNECTIONS

Power supply decoupling capacitors should be added as shown in Figure 4. Best performance occurs using a 1 to 10 $\mu$ F tantalum capacitor at  $-V_{CC}$ . Applications with less

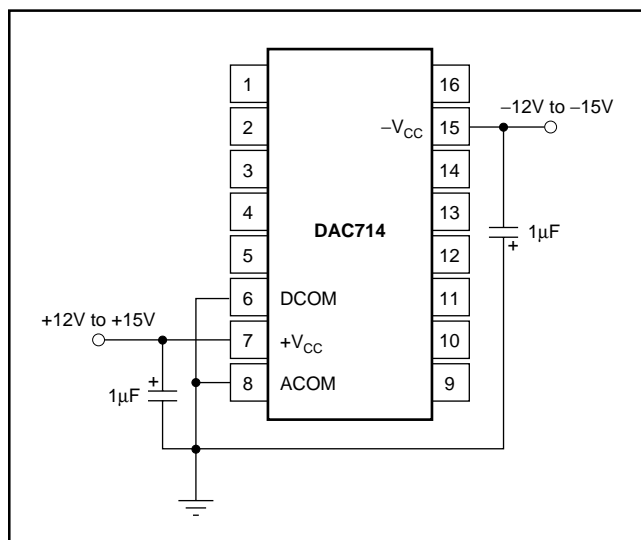

FIGURE 4. Power Supply Connections.

critical settling time may be able to use 0.01 $\mu$ F at  $-V_{CC}$  as well as at  $+V_{CC}$ . The capacitors should be located close to the package.

The DAC714 has separate ANALOG COMMON and DIGITAL COMMON pins. The current through DCOM is mostly switching transients and are up to 1mA peak in amplitude. The current through ACOM is typically 5 $\mu$ A for all codes.

Use separate analog and digital ground planes with a single interconnection point to minimize ground loops. The analog pins are located adjacent to each other to help isolate analog from digital signals. Analog signals should be routed as far as possible from digital signals and should cross them at right angles. A solid analog ground plane around the D/A package, as well as under it in the vicinity of the analog and power supply pins, will isolate the D/A from switching currents. It is recommended that DCOM and ACOM be connected directly to the ground planes under the package.

If several DAC714s are used or if DAC714 shares supplies with other components, connecting the ACOM and DCOM lines to together once at the power supplies rather than at each chip may give better results.

### LOAD CONNECTIONS

Since the reference point for  $V_{OUT}$  and  $V_{REF OUT}$  is the ACOM pin, it is important to connect the D/A converter load directly to the ACOM pin. Refer to Figure 5.

Lead and contact resistances are represented by  $R_1$  through  $R_3$ . As long as the load resistance  $R_L$  is constant,  $R_1$  simply introduces a gain error and can be removed by gain adjustment of the D/A or system-wide gain calibration.  $R_2$  is part of  $R_L$  if the output voltage is sensed at ACOM.

In some applications it is impractical to return the load to the ACOM pin of the D/A converter. Sensing the output voltage at the SYSTEM GROUND point is reasonable, because there is no change in DAC714 ACOM current, provided that  $R_3$  is a low-resistance ground plane or conductor. In this case you may wish to connect DCOM to SYSTEM GROUND as well.



## GAIN AND OFFSET ADJUST

### Connections Using Potentiometers

GAIN and OFFSET adjust pins provide for trim using external potentiometers. 15-turn potentiometers provide sufficient resolution. Range of adjustment of these trims is at least  $\pm 0.3\%$  of Full Scale Range. Refer to Figure 6.

### Using D/A Converters

The GAIN ADJUST and OFFSET ADJUST circuits of the DAC714 have been arranged so that these points may be easily driven by external D/A converters. Refer to Figure 7. 12-bit D/A converters provide an OFFSET adjust resolution and a GAIN adjust resolution of  $30\mu\text{V}$  to  $50\mu\text{V}$  per LSB step.

Nominal values of GAIN and OFFSET occur when the D/A converters outputs are at approximately half scale, +5V.

## OUTPUT VOLTAGE RANGE CONNECTIONS

The DAC714 output amplifier is connected internally to provide a 20V output range. For other ranges and configurations, see Figures 6 and 7.

## DIGITAL INTERFACE

### SERIAL INTERFACE

The DAC714 has a serial interface with two data buffers which can be used for either synchronous or asynchronous updating of multiple D/A converters.  $\overline{A0}$  is the enable control for the input shift register.  $\overline{A1}$  is the enable for the D/A Latch.  $\overline{CLK}$  is used to strobe data into the latches enabled by  $\overline{A0}$  and  $\overline{A1}$ . A CLR function is also provided and when enabled it sets the shift register and the D/A Latch to  $0000_H$  (output voltage is midscale).

Multiple DAC714s can be connected to the same  $\overline{CLK}$  and data lines in two ways. The output of the serial shift register is available as SDO so that any number of DAC714s can be cascaded on the same input bit stream as shown in Figures 8 and 9. This configuration allows all D/A converters to be updated simultaneously and requires a minimum number of control signals. These configurations do require  $16N$   $\overline{CLK}$  cycles to load any given D/A converter, where N is the number of D/A converters.

The DAC714 can also be connected in parallel as shown in Figure 10. This configuration allows any D/A converter in the system to be updated in a maximum of 16 CLK cycles.

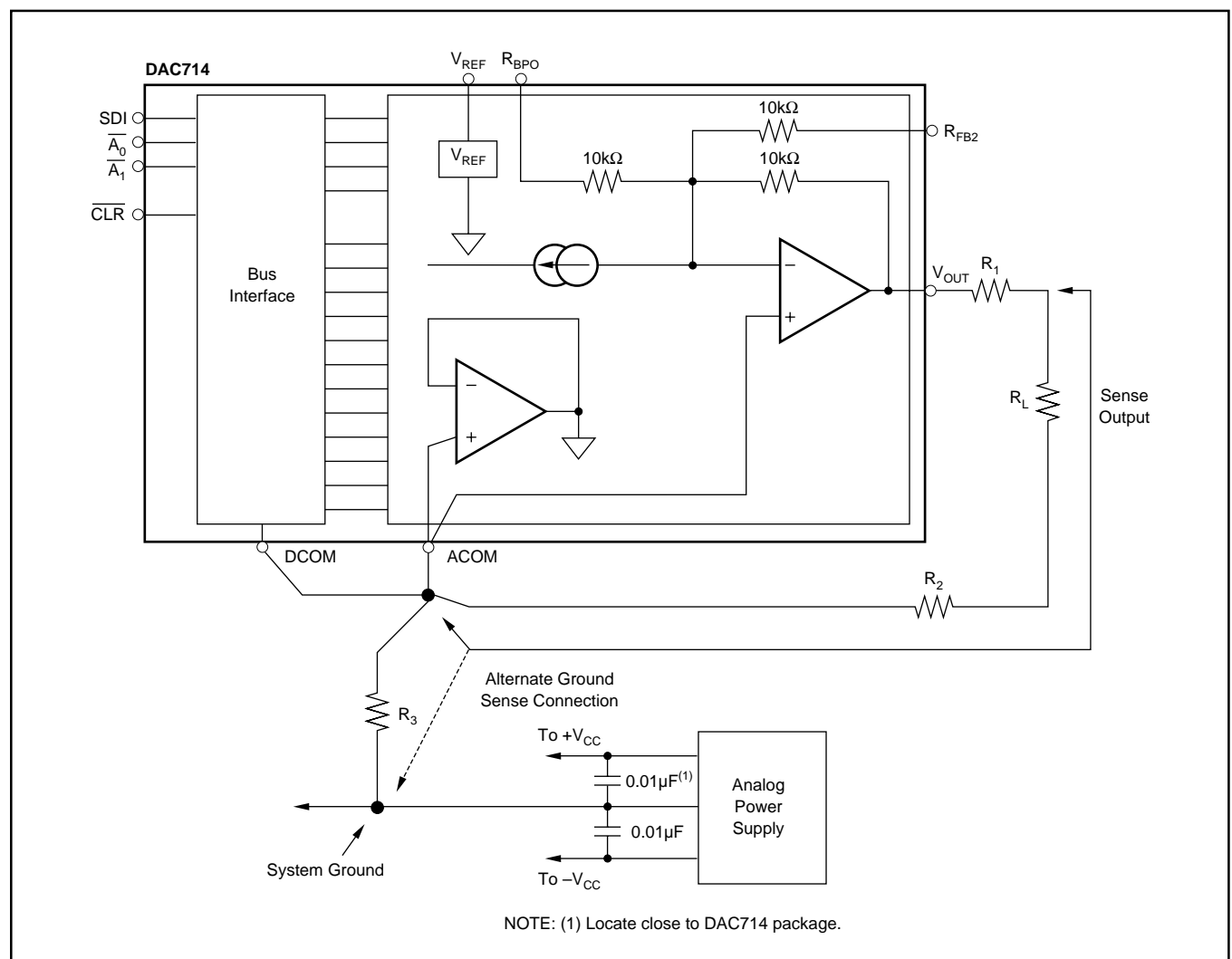

FIGURE 5. System Ground Considerations for High-Resolution D/A Converters.

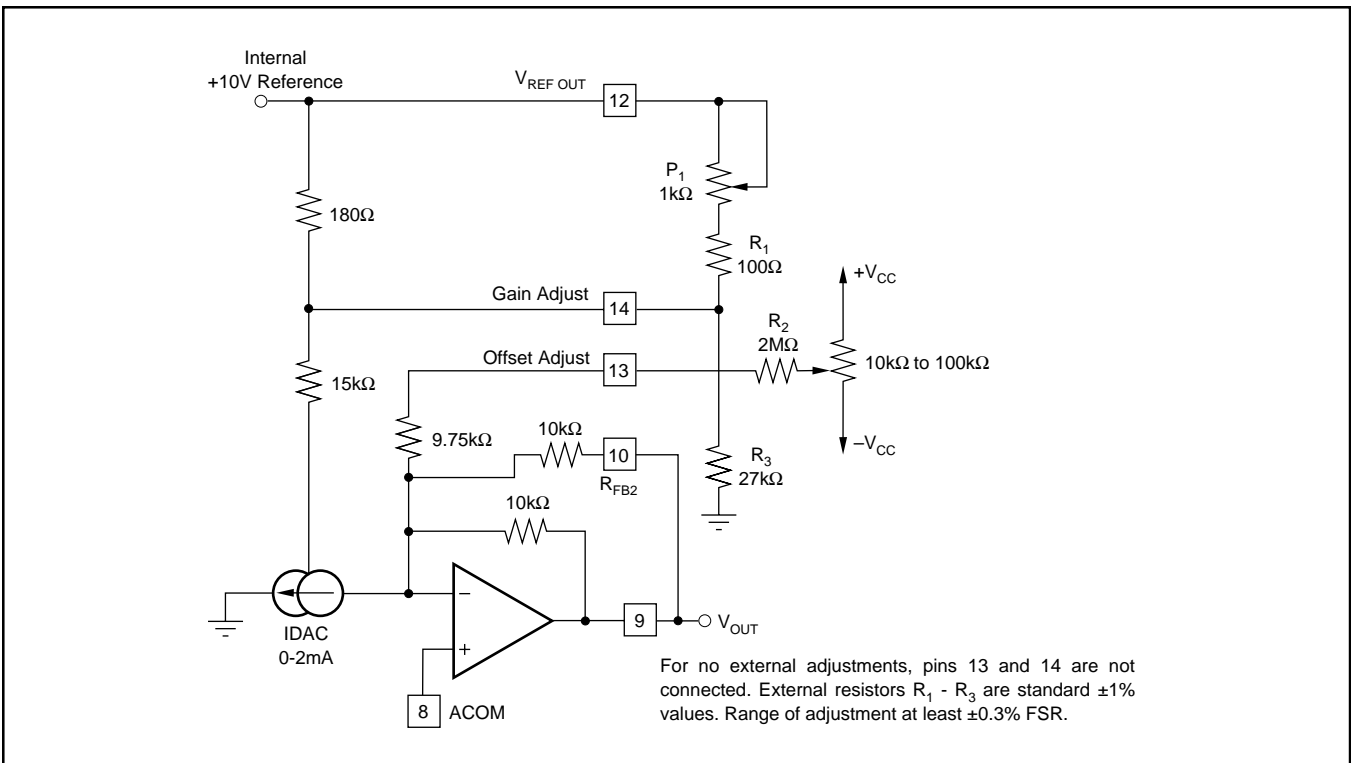

FIGURE 6a. Manual Offset and Gain Adjust Circuits; Unipolar Mode (0V to +10V output range).

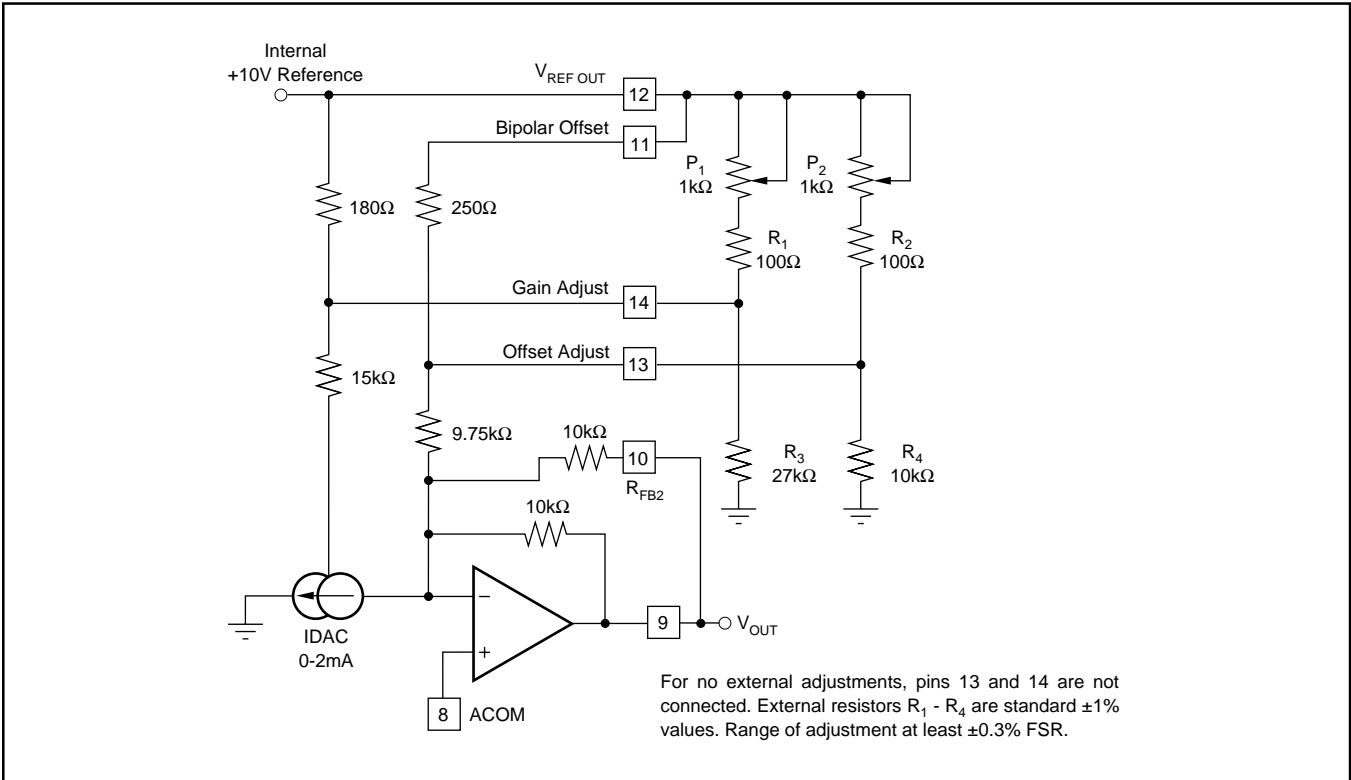

FIGURE 6b. Manual Offset and Gain Adjust Circuits; Bipolar Mode (-5V to +5V output range).

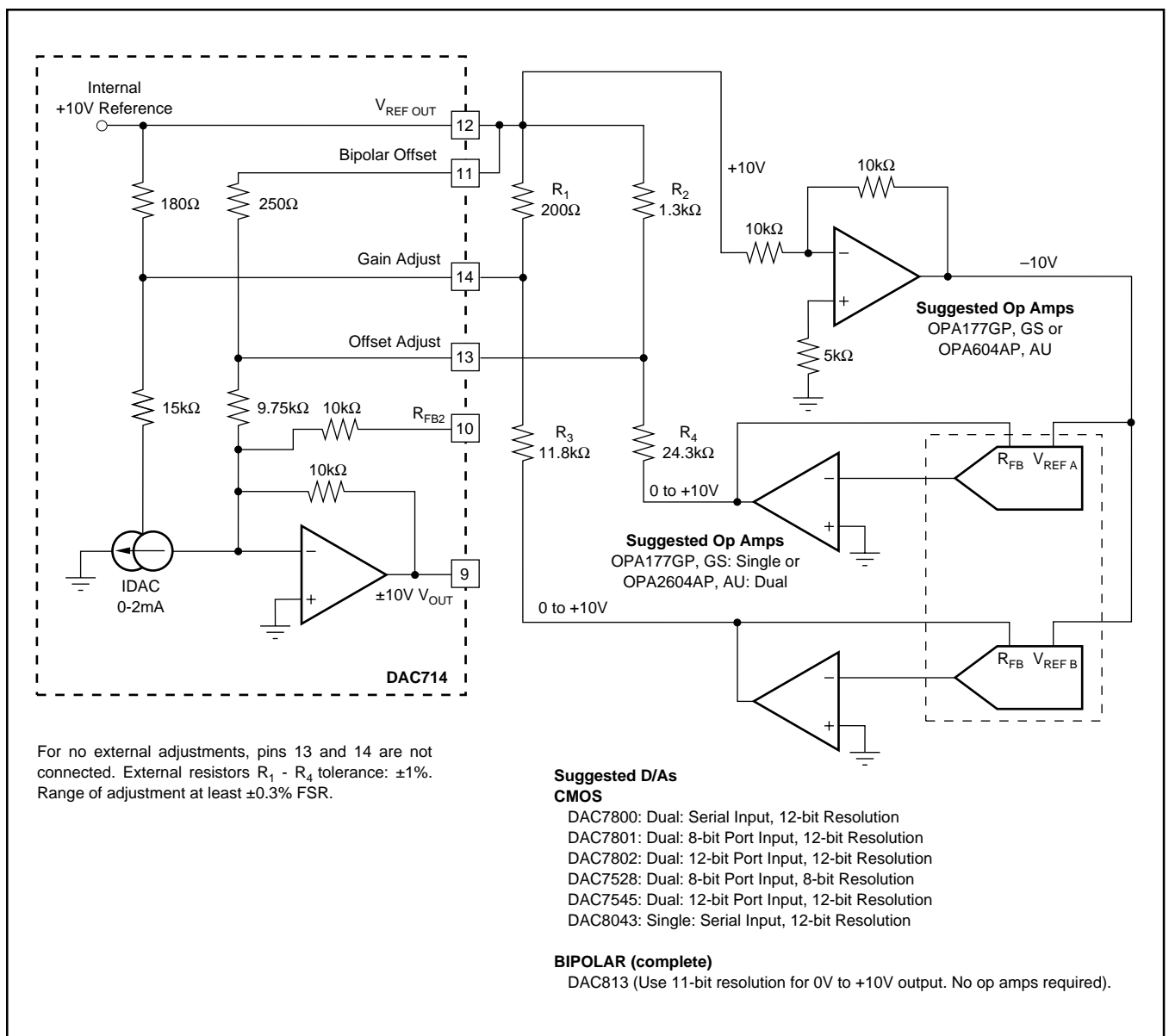

FIGURE 7. Gain and Offset Adjustment in the Bipolar Mode Using D/A Converters ( $-10V$  to  $+10V$  output range).

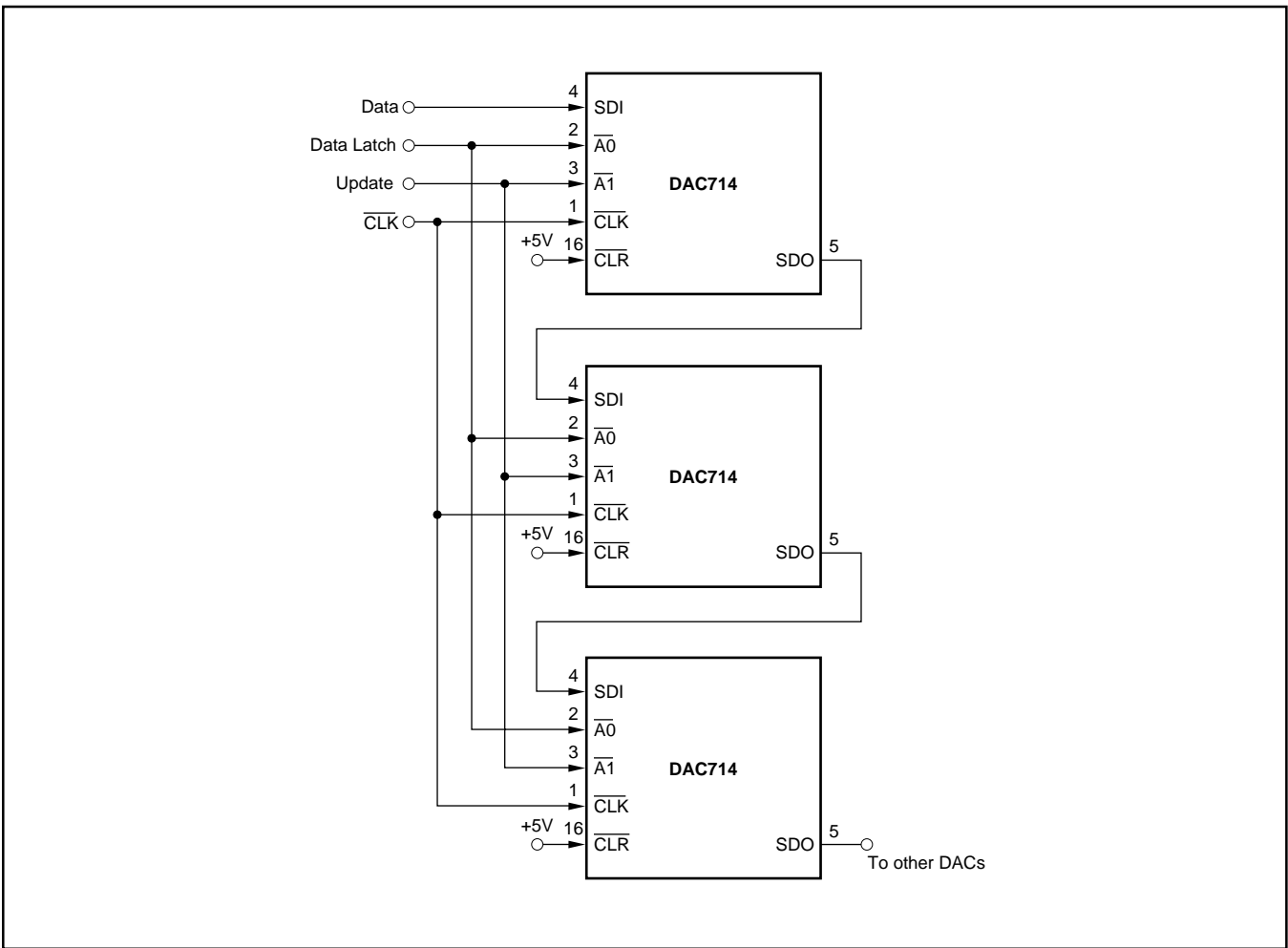

FIGURE 8a. Cascaded Serial Bus Connection with Synchronous Update.

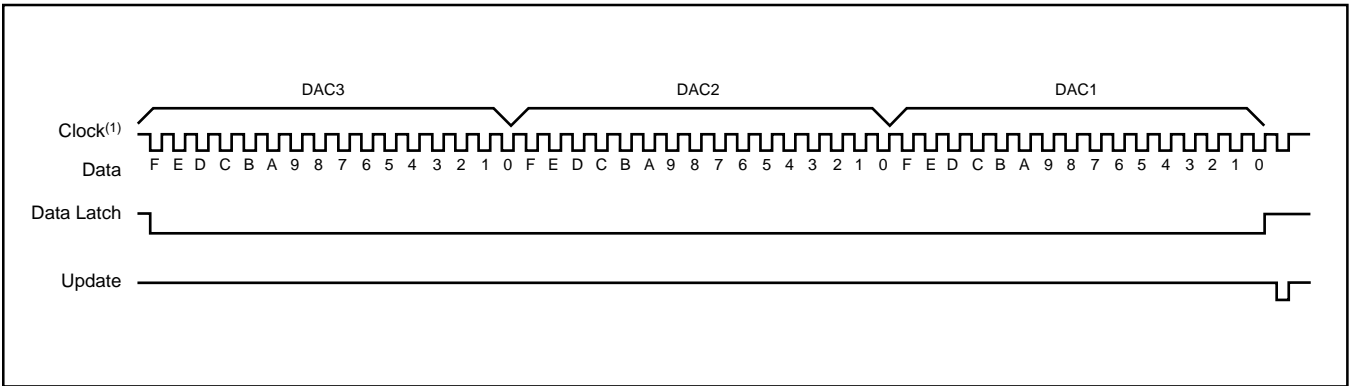

FIGURE 8b. Timing Diagram For Figure 8a.

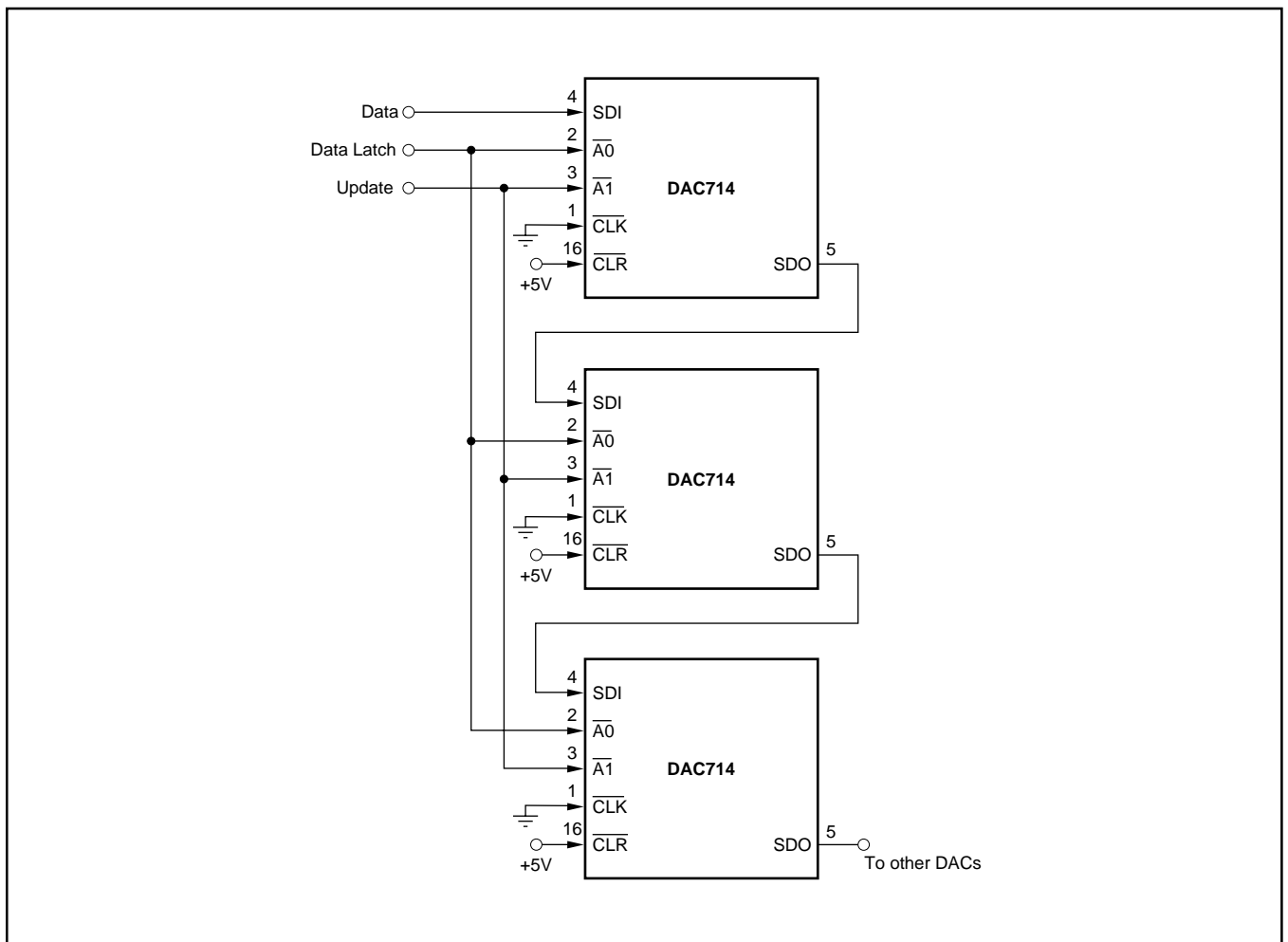

FIGURE 9a. Cascaded Serial Bus Connection with Asynchronous Update.

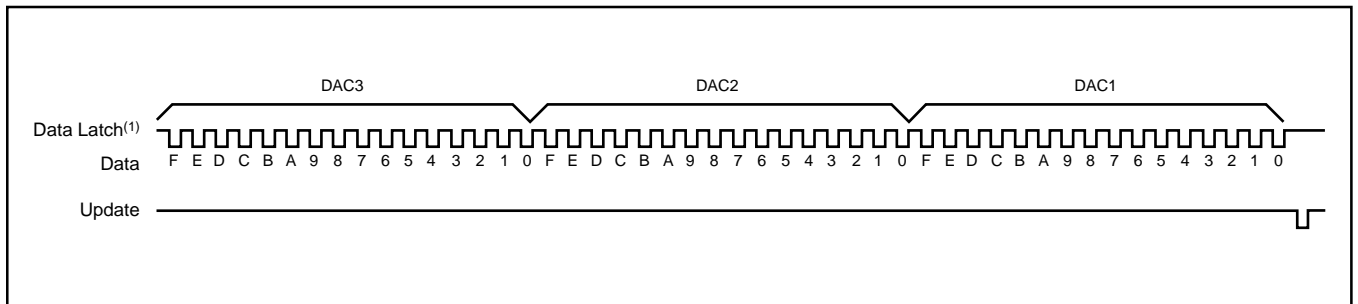

FIGURE 9b. Timing Diagram For Figure 9a.

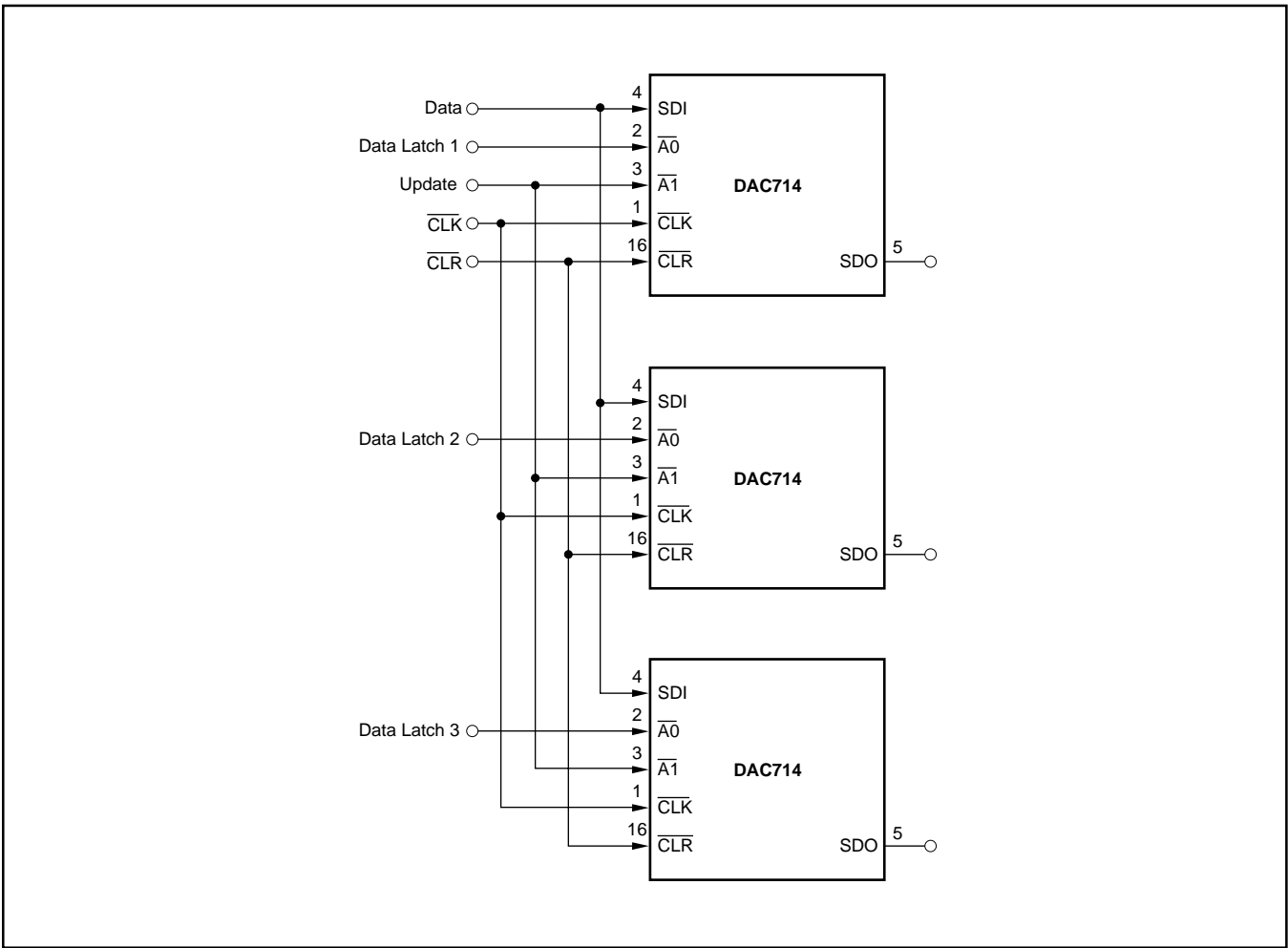

FIGURE 10a. Parallel Bus Connection.

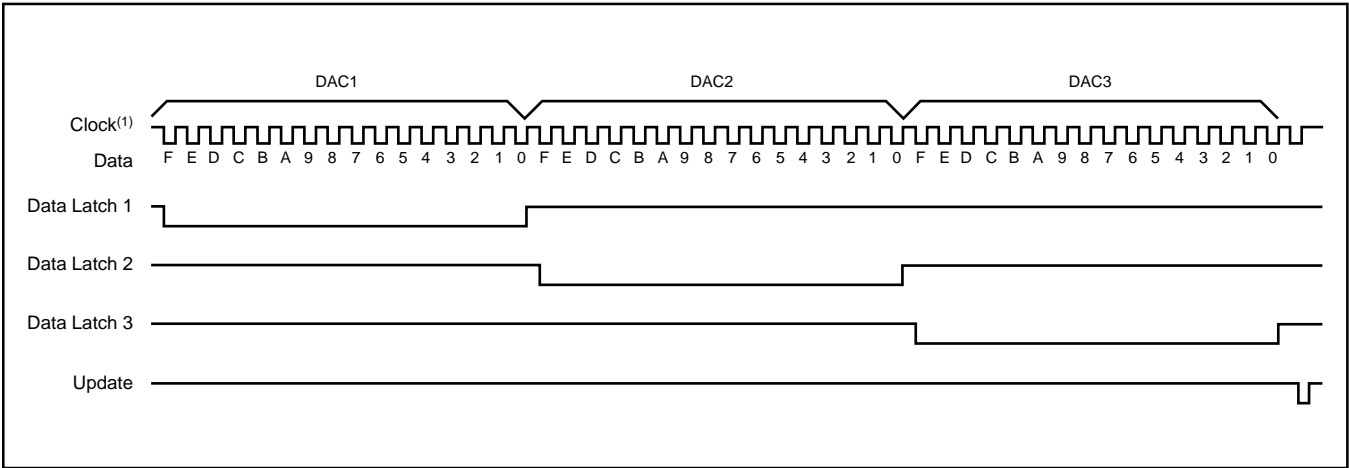

FIGURE 10b. Timing Diagram For Figure 10a.

## PACKAGING INFORMATION

Orderable Device	Status (1)	Package Type	Package Drawing	Pins	Package Qty	Eco Plan (2)	Lead/Ball Finish (6)	MSL Peak Temp (3)	Op Temp (°C)	Device Marking (4/5)	Samples
DAC714P	NRND	PDIP	N	16	25	Green (RoHS & no Sb/Br)	NIPDAU	N / A for Pkg Type	-40 to 85	DAC714P	
DAC714U	ACTIVE	SOIC	DW	16	40	Green (RoHS & no Sb/Br)	NIPDAU	Level-3-260C-168 HR	-40 to 85	DAC714U	<a href="#">Samples</a>
DAC714U/1K	ACTIVE	SOIC	DW	16	1000	Green (RoHS & no Sb/Br)	NIPDAU	Level-3-260C-168 HR	-40 to 85	DAC714U	<a href="#">Samples</a>
DAC714U/1KG4	ACTIVE	SOIC	DW	16	1000	Green (RoHS & no Sb/Br)	NIPDAU	Level-3-260C-168 HR	-40 to 85	DAC714U	<a href="#">Samples</a>

(1) The marketing status values are defined as follows:

**ACTIVE:** Product device recommended for new designs.

**LIFEBUY:** TI has announced that the device will be discontinued, and a lifetime-buy period is in effect.

**NRND:** Not recommended for new designs. Device is in production to support existing customers, but TI does not recommend using this part in a new design.

**PREVIEW:** Device has been announced but is not in production. Samples may or may not be available.

**OBSOLETE:** TI has discontinued the production of the device.

(2) **RoHS:** TI defines "RoHS" to mean semiconductor products that are compliant with the current EU RoHS requirements for all 10 RoHS substances, including the requirement that RoHS substance do not exceed 0.1% by weight in homogeneous materials. Where designed to be soldered at high temperatures, "RoHS" products are suitable for use in specified lead-free processes. TI may reference these types of products as "Pb-Free".

**RoHS Exempt:** TI defines "RoHS Exempt" to mean products that contain lead but are compliant with EU RoHS pursuant to a specific EU RoHS exemption.

**Green:** TI defines "Green" to mean the content of Chlorine (Cl) and Bromine (Br) based flame retardants meet JS709B low halogen requirements of  $\leq 1000$ ppm threshold. Antimony trioxide based flame retardants must also meet the  $\leq 1000$ ppm threshold requirement.

(3) MSL, Peak Temp. - The Moisture Sensitivity Level rating according to the JEDEC industry standard classifications, and peak solder temperature.

(4) There may be additional marking, which relates to the logo, the lot trace code information, or the environmental category on the device.

(5) Multiple Device Markings will be inside parentheses. Only one Device Marking contained in parentheses and separated by a "-" will appear on a device. If a line is indented then it is a continuation of the previous line and the two combined represent the entire Device Marking for that device.

(6) Lead/Ball Finish - Orderable Devices may have multiple material finish options. Finish options are separated by a vertical ruled line. Lead/Ball Finish values may wrap to two lines if the finish value exceeds the maximum column width.

**Important Information and Disclaimer:** The information provided on this page represents TI's knowledge and belief as of the date that it is provided. TI bases its knowledge and belief on information provided by third parties, and makes no representation or warranty as to the accuracy of such information. Efforts are underway to better integrate information from third parties. TI has taken and

continues to take reasonable steps to provide representative and accurate information but may not have conducted destructive testing or chemical analysis on incoming materials and chemicals. TI and TI suppliers consider certain information to be proprietary, and thus CAS numbers and other limited information may not be available for release.

In no event shall TI's liability arising out of such information exceed the total purchase price of the TI part(s) at issue in this document sold by TI to Customer on an annual basis.



**TAPE AND REEL INFORMATION**

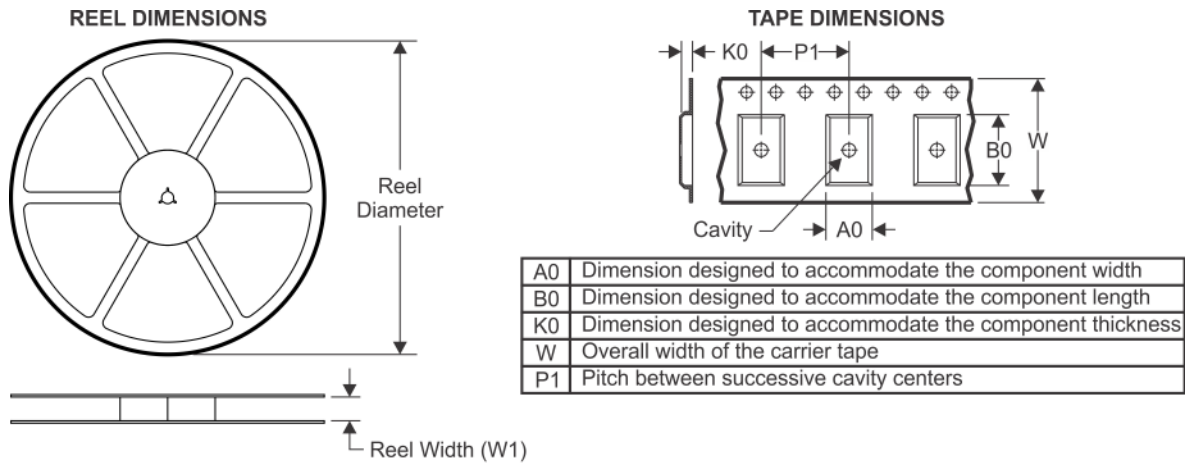

**QUADRANT ASSIGNMENTS FOR PIN 1 ORIENTATION IN TAPE**

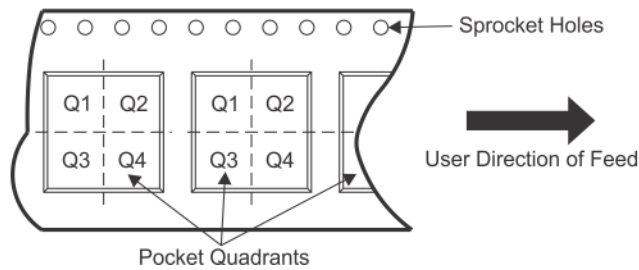

\*All dimensions are nominal

Device	Package Type	Package Drawing	Pins	SPQ	Reel Diameter (mm)	Reel Width W1 (mm)	A0 (mm)	B0 (mm)	K0 (mm)	P1 (mm)	W (mm)	Pin1 Quadrant
DAC714U/1K	SOIC	DW	16	1000	330.0	16.4	10.75	10.7	2.7	12.0	16.0	Q1

TAPE AND REEL BOX DIMENSIONS



\*All dimensions are nominal

Device	Package Type	Package Drawing	Pins	SPQ	Length (mm)	Width (mm)	Height (mm)
DAC714U/1K	SOIC	DW	16	1000	367.0	367.0	38.0

## GENERIC PACKAGE VIEW

**DW 16**

**SOIC - 2.65 mm max height**

7.5 x 10.3, 1.27 mm pitch

SMALL OUTLINE INTEGRATED CIRCUIT

This image is a representation of the package family, actual package may vary.  
Refer to the product data sheet for package details.

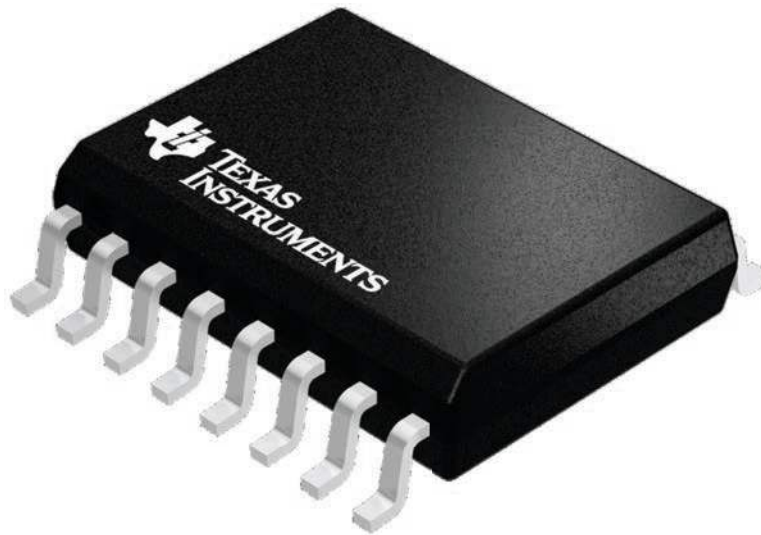

4224780/A



# DW0016A

# PACKAGE OUTLINE SOIC - 2.65 mm max height

SOIC

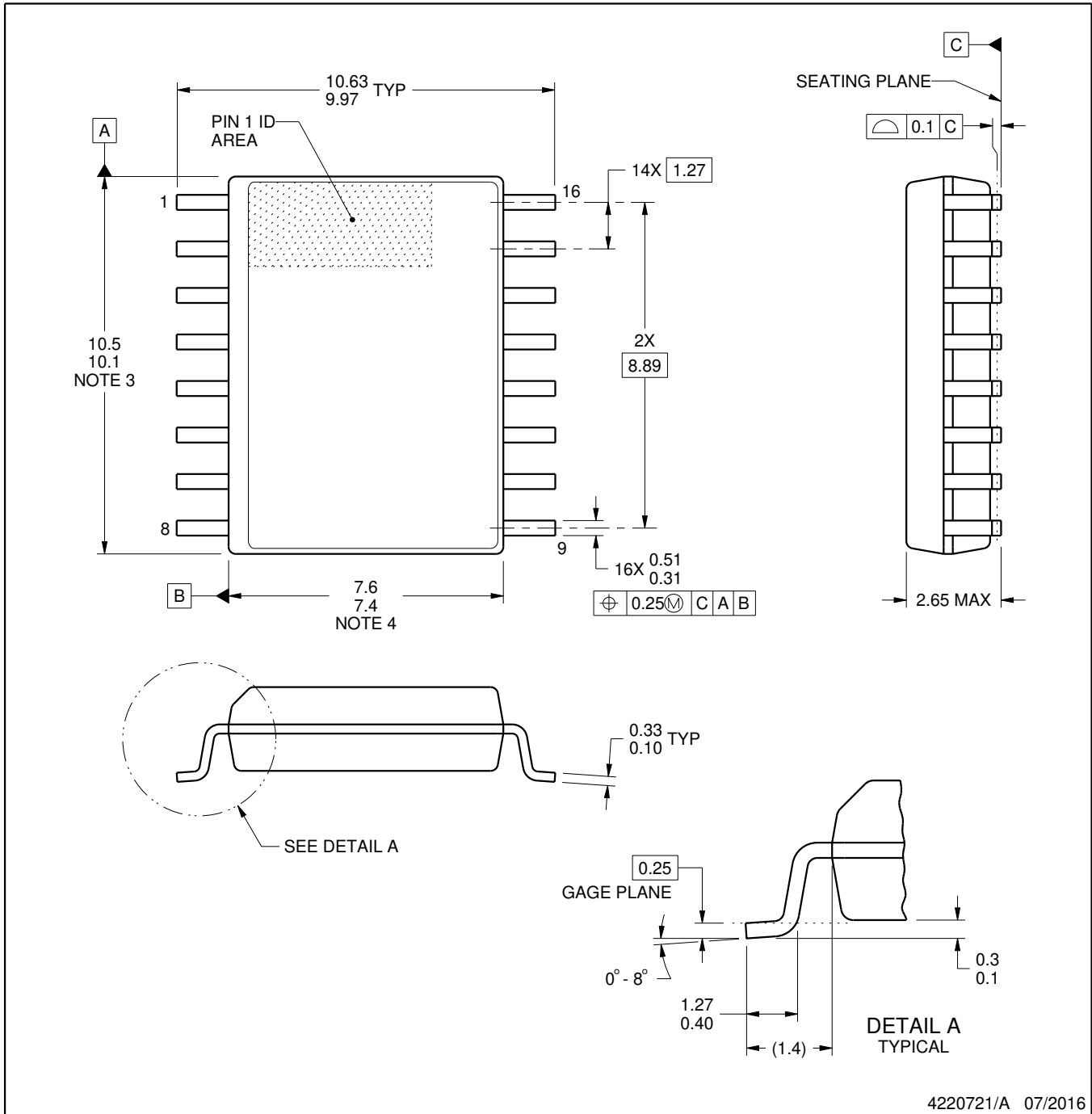

4220721/A 07/2016

### NOTES:

1. All linear dimensions are in millimeters. Dimensions in parenthesis are for reference only. Dimensioning and tolerancing per ASME Y14.5M.
2. This drawing is subject to change without notice.
3. This dimension does not include mold flash, protrusions, or gate burrs. Mold flash, protrusions, or gate burrs shall not exceed 0.15 mm, per side.
4. This dimension does not include interlead flash. Interlead flash shall not exceed 0.25 mm, per side.
5. Reference JEDEC registration MS-013.

# EXAMPLE BOARD LAYOUT

DW0016A

SOIC - 2.65 mm max height

SOIC

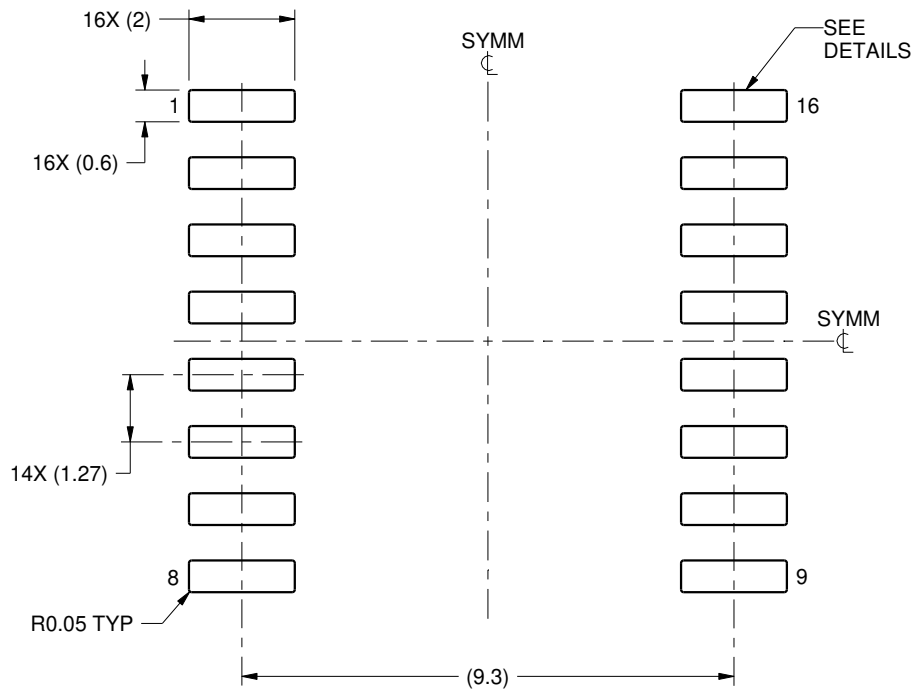

LAND PATTERN EXAMPLE  
SCALE:7X

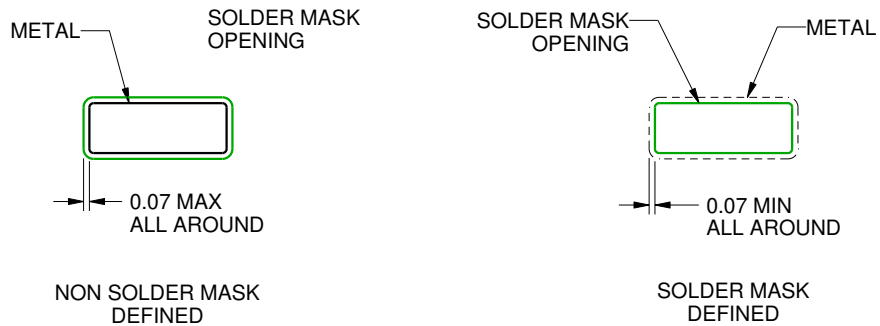

SOLDER MASK DETAILS

4220721/A 07/2016

NOTES: (continued)

6. Publication IPC-7351 may have alternate designs.

7. Solder mask tolerances between and around signal pads can vary based on board fabrication site.

# EXAMPLE STENCIL DESIGN

DW0016A

SOIC - 2.65 mm max height

SOIC

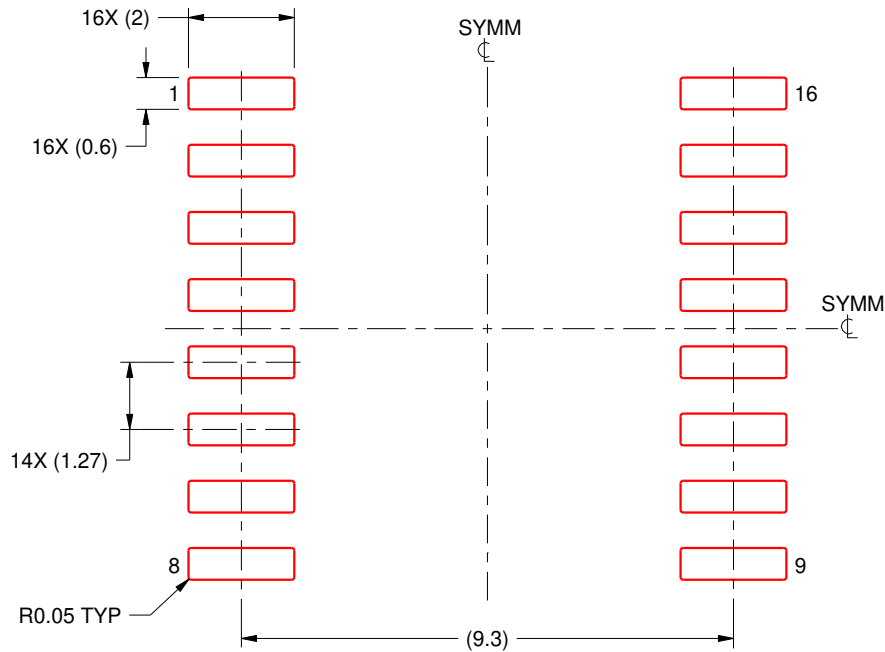

SOLDER PASTE EXAMPLE  
BASED ON 0.125 mm THICK STENCIL  
SCALE:7X

4220721/A 07/2016

NOTES: (continued)

8. Laser cutting apertures with trapezoidal walls and rounded corners may offer better paste release. IPC-7525 may have alternate design recommendations.
9. Board assembly site may have different recommendations for stencil design.

N (R-PDIP-T\*\*)

PLASTIC DUAL-IN-LINE PACKAGE

16 PINS SHOWN



- NOTES:
- A. All linear dimensions are in inches (millimeters).
  - B. This drawing is subject to change without notice.
  - C Falls within JEDEC MS-001, except 18 and 20 pin minimum body length (Dim A).
  - D The 20 pin end lead shoulder width is a vendor option, either half or full width.

4040049/E 12/2002

## IMPORTANT NOTICE AND DISCLAIMER

TI PROVIDES TECHNICAL AND RELIABILITY DATA (INCLUDING DATASHEETS), DESIGN RESOURCES (INCLUDING REFERENCE DESIGNS), APPLICATION OR OTHER DESIGN ADVICE, WEB TOOLS, SAFETY INFORMATION, AND OTHER RESOURCES "AS IS" AND WITH ALL FAULTS, AND DISCLAIMS ALL WARRANTIES, EXPRESS AND IMPLIED, INCLUDING WITHOUT LIMITATION ANY IMPLIED WARRANTIES OF MERCHANTABILITY, FITNESS FOR A PARTICULAR PURPOSE OR NON-INFRINGEMENT OF THIRD PARTY INTELLECTUAL PROPERTY RIGHTS.

These resources are intended for skilled developers designing with TI products. You are solely responsible for (1) selecting the appropriate TI products for your application, (2) designing, validating and testing your application, and (3) ensuring your application meets applicable standards, and any other safety, security, or other requirements. These resources are subject to change without notice. TI grants you permission to use these resources only for development of an application that uses the TI products described in the resource. Other reproduction and display of these resources is prohibited. No license is granted to any other TI intellectual property right or to any third party intellectual property right. TI disclaims responsibility for, and you will fully indemnify TI and its representatives against, any claims, damages, costs, losses, and liabilities arising out of your use of these resources.

TI's products are provided subject to TI's Terms of Sale ([www.ti.com/legal/termsofsale.html](http://www.ti.com/legal/termsofsale.html)) or other applicable terms available either on [ti.com](http://ti.com) or provided in conjunction with such TI products. TI's provision of these resources does not expand or otherwise alter TI's applicable warranties or warranty disclaimers for TI products.

Mailing Address: Texas Instruments, Post Office Box 655303, Dallas, Texas 75265  
Copyright © 2020, Texas Instruments Incorporated