

THIS IS ISSUED IN STRICT CONFIDENCE THAT IT IS NOT USED AS A BASIS FOR MANUFACTURE OR SALE AND THAT IT IS NOT COPIED, REPRINTED OR DISCLOSED TO A THIRD PARTY EITHER WHOLLY OR IN PART WITHOUT THE PRIOR WRITTEN CONSENT OF CAL TEST ELECTRONICS, INC.

- STANDARD PROBE BODY WITH 4 mm BANANA PLUG CONTACT ON THE TIP.
- SPECIFICATIONS:  
INSULATOR: POLYAMIDE (NYLON).  
PROBE TIP & BANANA PLUG JACK: BRASS, NICKEL PLATED  
BANANA PLUG CONTACT: BeCu, NICKEL PLATED
- RATING:  
VOLTAGE: (PER IEC 61010-031)  
WITH SAFETY CAP: 1,000 V CAT III / 600 V CAT IV P2  
WITHOUT SAFETY CAP: 1,000 V CAT II P2  
CURRENT: 36 A MAX.  
TEMPERATURE: -20° TO +80°C.

CE DECLARATION OF CONFORMITY  
CONFORMS TO RoHS 2, ANNEX III 6(c) EXEMPTION.

REVISIONS			
REV.	DESCRIPTIONS	DATE	APPROVED
—	CLASS A RELEASED	7/21/00	
A	ADDED CAGE CODE; UPDATED IEC VOLTAGE SPECIFICATION, WAS CAT III.	6/10/05	

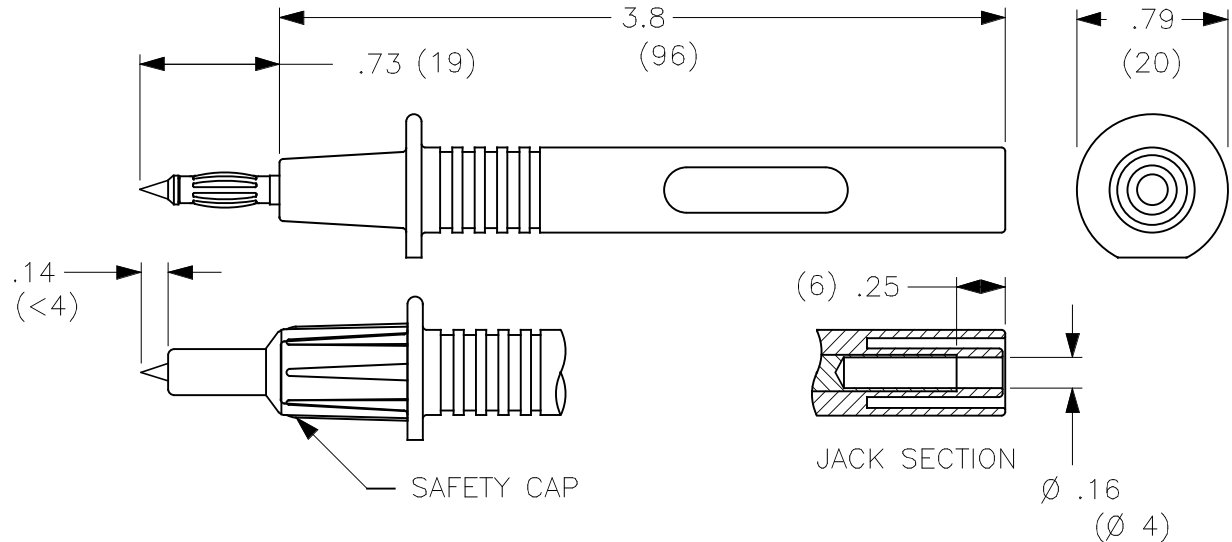

### PART NUMBERS

**CT2265-#**

COLOR: **0** - BLACK  
**2** - RED

THIRD ANGLE PROJECTION		UNLESS OTHERWISE SPECIFIED DIMENSIONS ARE IN INCHES TOLERANCES ARE: FRACTIONS    DECIMALS ± 1/32        .XX ± .02 .XXX ± .005 DO NOT SCALE DRAWING	CONTRACT NO.		<b>Cal Test Electronics</b> 22820 Savi Ranch Parkway Yorba Linda, CA 92887-4610			
			APPROVALS	DATE	TITLE			
MATERIAL		DRAWN	WDH	7/21/00	<b>STANDARD PROBE BODY w/4 mm          BANANA PLUG CONTACT ON TIP</b>			
FINISH		CHECKED			SIZE	CAGE CODE	DWG. NO.	REV.
NEXT ASSY		ENGR.			<b>A</b>	<b>43F45</b>	<b>P226500</b>	<b>B</b>
USED ON		DESIGN ACTIVITY			SCALE	1:1	SHEET	1 OF 1
APPLICATION								