



Z86D86

***28-Pin Low-Voltage OTP
Microcontroller***

Preliminary Product Specification

PS008905-0105



This publication is subject to replacement by a later edition. To determine whether a later edition exists, or to request copies of publications, contact:

ZiLOG Worldwide Headquarters

532 Race Street
San Jose, CA 95126-3432
Telephone: 408.558.8500
Fax: 408.558.8300
www.ZiLOG.com

ZiLOG is a registered trademark of ZiLOG Inc. in the United States and in other countries. All other products and/or service names mentioned herein may be trademarks of the companies with which they are associated.

Document Disclaimer

© 2005 by ZiLOG, Inc. All rights reserved. Information in this publication concerning the devices, applications, or technology described is intended to suggest possible uses and may be superseded. ZiLOG, INC. DOES NOT ASSUME LIABILITY FOR OR PROVIDE A REPRESENTATION OF ACCURACY OF THE INFORMATION, DEVICES, OR TECHNOLOGY DESCRIBED IN THIS DOCUMENT. ZiLOG ALSO DOES NOT ASSUME LIABILITY FOR INTELLECTUAL PROPERTY INFRINGEMENT RELATED IN ANY MANNER TO USE OF INFORMATION, DEVICES, OR TECHNOLOGY DESCRIBED HEREIN OR OTHERWISE. Except with the express written approval ZiLOG, use of information, devices, or technology as critical components of life support systems is not authorized. No licenses or other rights are conveyed, implicitly or otherwise, by this document under any intellectual property rights.



Revision History

Each instance in Table 1 reflects a change to this document from its previous revision. To see more detail, click the appropriate link in the table.

Table 1. Revision History of this Document

Date	Revision Level	Section	Description	Page #
January 2005	05		Made minor corrections to Figure 23 Port 0 and 1 Mode Register.	29



Table of Contents

Revision History	iii
Features	1
General Description	2
Pin Description	5
Absolute Maximum Ratings	6
Standard Test Conditions	7
Capacitance	7
DC Characteristics	8
AC Characteristics	10
Pin Functions (Standard Mode)	12
XTAL1 Crystal 1 (Time-Based Input)	12
XTAL2 Crystal 2 (Time-Based Output)	12
Port 0 (P07–P00)	12
Port 2 (P27–P20)	13
Port 3 (P37–P31)	14
Comparator Inputs	16
Comparator Outputs	16
Functional Description	18
Program Memory	18
RAM	18
Expanded Register File	18
Register File	32
Stack	33
Counter/Timer Registers	34
Counter/Timer Functional Blocks	43
Interrupts	54
Clock	56
Power-On Reset (POR)	57
HALT	58
STOP	58
Port Configuration Register (PCON)	59
Stop-Mode Recovery Register (SMR)	59
Stop-Mode Recovery Register 2 (SMR2)	64
Watch-Dog Timer Mode Register (WDTMR)	65
Mask Selectable Options	68



Low Voltage/Standby	68
Low Battery Detection and Flag	68
Ordering Information	69
Z86D86 8.0 MHz	70
Codes	71
Precharacterization Product	71
Customer Feedback Form	72
Z86D86 28-Pin Low-Voltage OTP Microcontroller	72
Customer Information	72
Product Information	72
Return Information	72
Problem Description or Suggestion	72



List of Figures

Figure 1. Counter/Timers Diagram	3
Figure 2. Functional Block Diagram	4
Figure 3. 28-Pin DIP/SOIC Pin Assignment	5
Figure 4. Test Load Diagram	7
Figure 5. Timing Diagram	10
Figure 6. Port 0 Configuration	13
Figure 7. Port 2 Configuration	14
Figure 8. Port 3 Configuration	15
Figure 9. Port 3 Counter/Timer Output Configuration	17
Figure 10. Program Memory Map (32K ROM)	18
Figure 11. Expanded Register File Architecture	20
Figure 12. Register Pointer Register	21
Figure 13. TC8 Control Register—(0D) 0H: Read/Write Except Where Noted	21
Figure 14. T8 and T16 Common Control Functions—(0D) 1H: Read/Write ...	22
Figure 15. T16 Control Register—(0D) 2H: Read/Write Except Where Noted .	23
Figure 16. Low Battery Detection	24
Figure 17. Stop-Mode Recovery Register—(0F) 0BH: D6–D0 = Write Only, D7 = Read Only	25
Figure 18. Stop-Mode Recovery Register 2—(0F) 0DH: D2–D4, D6 Write Only	26
Figure 19. Watch-Dog Timer Register—(0F) 0FH: Write Only	27
Figure 20. Port Configuration Register (PCON)—(0F) 0H: Write Only	27
Figure 21. Port 2 Mode Register—F6H: Write Only	28
Figure 22. Port 3 Mode Register—F7H: Write Only	28
Figure 23. Port 0 and 1 Mode Register—F8H: Write Only	29
Figure 24. Interrupt Priority Register—F9H: Write Only	30
Figure 25. Interrupt Request Register—FAH: Read/Write	30
Figure 26. Interrupt Mask Register—FBH: Read/Write	31
Figure 27. Flag Register—FCH: Read/Write	31
Figure 28. Register Pointer—FDH: Read/Write	32
Figure 29. Stack Pointer High—FEH: Read/Write	32
Figure 30. Stack Pointer Low—FFH: Read/Write	32
Figure 31. Register Pointer	33
Figure 32. Glitch Filter Circuitry	44



Figure 33. 8-Bit Counter/Timer Circuits	44
Figure 34. Transmit Mode Flowchart	46
Figure 35. T8_OUT in Single-Pass Mode	47
Figure 36. T8_OUT in Modulo-N Mode	47
Figure 37. Demodulation Mode Count Capture Flowchart	48
Figure 38. Demodulation Mode Flowchart	49
Figure 39. 16-Bit Counter/Timer Circuits	50
Figure 40. T16_OUT in Single-Pass Mode	51
Figure 41. T16_OUT in Modulo-N Mode	51
Figure 42. Ping-Pong Mode	53
Figure 43. Output Circuit	54
Figure 44. Interrupt Block Diagram	55
Figure 45. Oscillator Configuration	57
Figure 46. Port Configuration Register (PCON)—Write Only	59
Figure 47. Stop-Mode Recovery Register	60
Figure 48. SCLK Circuit	60
Figure 49. Stop-Mode Recovery Source	62
Figure 50. Stop-Mode Recovery Register 2—(0F) DH:D2–D4, D6 Write Only	64
Figure 51. Watch-Dog Timer Mode Register—Write Only	66
Figure 52. Resets and WDT	67
Figure 53. 28-Pin SOIC Package Diagram	69
Figure 54. 28-Pin DIP Package Diagram	70
Figure 55. Ordering Codes Example	71



List of Tables

Table 1.	Revision History of this Document	iii
Table 2.	Z86D86 Features	1
Table 3.	28-Pin DIP and SOIC Pin Identification	5
Table 4.	Absolute Maximum Ratings	6
Table 5.	Capacitance	7
Table 6.	DC Characteristics	8
Table 7.	AC Characteristics	11
Table 8.	Pin Assignments	16
Table 9.	Expanded Register Group D	34
Table 10.	LBD(D)0C—Low Battery Detection Register	35
Table 11.	HI8(D)0Bh	35
Table 12.	L08(D)0Ah	35
Table 13.	HI16(D)09h	36
Table 14.	L016(D)08h	36
Table 15.	TC16H(D)07h	36
Table 16.	TC16L(D)06h	36
Table 17.	TC8H(D)05h	37
Table 18.	TC8L(D)04h	37
Table 19.	CTR0 (D)00 Counter/Timer8 Control Register	37
Table 20.	CTR1(D)01h Register	39
Table 21.	CTR2 (D)02h: Counter/Timer16 Control Register	42
Table 22.	Interrupt Types, Sources, and Vectors	55
Table 23.	IRQ Register*	56
Table 24.	Stop-Mode Recovery Source	63
Table 25.	SMR2(F)0Dh: Stop-Mode Recovery Register 2	65
Table 26.	WDT Time Select*	66
Table 27.	Mask Selectable Options	68



Features

Table 1 shows some of the features of the Z86D86 microcontroller.

Table 1. Z86D86 Features

Device	ROM (KB)	RAM* (Bytes)	I/O Lines	Voltage Range
Z86D86	32	237	23	2.3 V to 5.5 V

Note: *General purpose

- Low Power Consumption—40 mW (Typical)
- Three Standby Modes
 - STOP—2 μ A
 - HALT—0.8 mA
 - Low Voltage
- Special Architecture to Automate Both Generation and Reception of Complex Pulses or Signals:
 - One Programmable 8-Bit Counter/Timer with Two Capture Registers and Two Load Registers
 - One Programmable 16-Bit Counter/Timer with One 16-Bit Capture Register Pair and One 16-Bit Load Register Pair
 - Programmable Input Glitch Filter for Pulse Reception
- Six Priority Interrupts
 - Three External
 - Two Assigned to Counter/Timers
 - One Low Battery Detection Interrupt
- Low Battery Detection with Flag
- Programmable Watch-Dog/Power-On Reset Circuits
- Two Independent Comparators with Programmable Interrupt Polarity
- Mask Selectable 200 \pm 50% K Ω Transistor Pull-Ups on Ports 0, 2.
- Programmable OTP Options:
 - Oscillator Selection: RC Oscillator vs. Crystal or Other Clock Source



- Oscillator Operational Mode: Normal High Frequency Operation Enabled or 32 KHz Operation Enabled
- Port 0: 0–3 Pull-Ups
- Port 0: 4–7 Pull-Ups
- Port 2: 0–7 Pull-Ups
- Port 0: 0–3 Mouse Mode: Normal Mode ($.5V_{DD}$ Input Threshold) vs. Mouse Mode ($.4V_{DD}$ Input Threshold)
- Port 3 does not feature the pull-up option.

General Description

The Z86D86 is a 28-pin one-time programmable (OTP) infrared (IR) microcontroller. Based on a single-chip Z8 microcontroller (MCU) design, the Z86D86 features 237 bytes of general-purpose RAM and 32 KB of OTP ROM. ZiLOG's CMOS microcontrollers offer fast executing, efficient use of memory, sophisticated interrupts, input/output bit-manipulation capabilities, automated pulse generation/reception, and internal key-scan pull-up transistors.

The Z86L825 architecture is based on ZiLOG's 8-bit microcontroller core, featuring an Expanded Register File to allow access to register-mapped peripherals, I/O circuits, and powerful counter/timer circuitry. The Z8 offers a flexible I/O scheme, an efficient register and address space structure, and a number of ancillary features that are useful in many consumer, automotive, computer peripheral, and battery-operated hand-held applications.

There are three basic address spaces available to support a wide range of configurations: program memory, register file, and Expanded Register File. The register file consists of 256 bytes of RAM. It includes 4 I/O port registers, 16 control and status registers, and 236 general-purpose registers. (Register FEh (SPH) can be used as a general-purpose register.) The Expanded Register File consists of two additional register groups (F and D).

The Z86D86 offers a new intelligent counter/timer architecture with 8-bit and 16-bit counter/timers (Figure 1). Also included are a large number of user-selectable modes and two on-board comparators to process analog signals with separate reference voltages (Figure 9 on page 17).

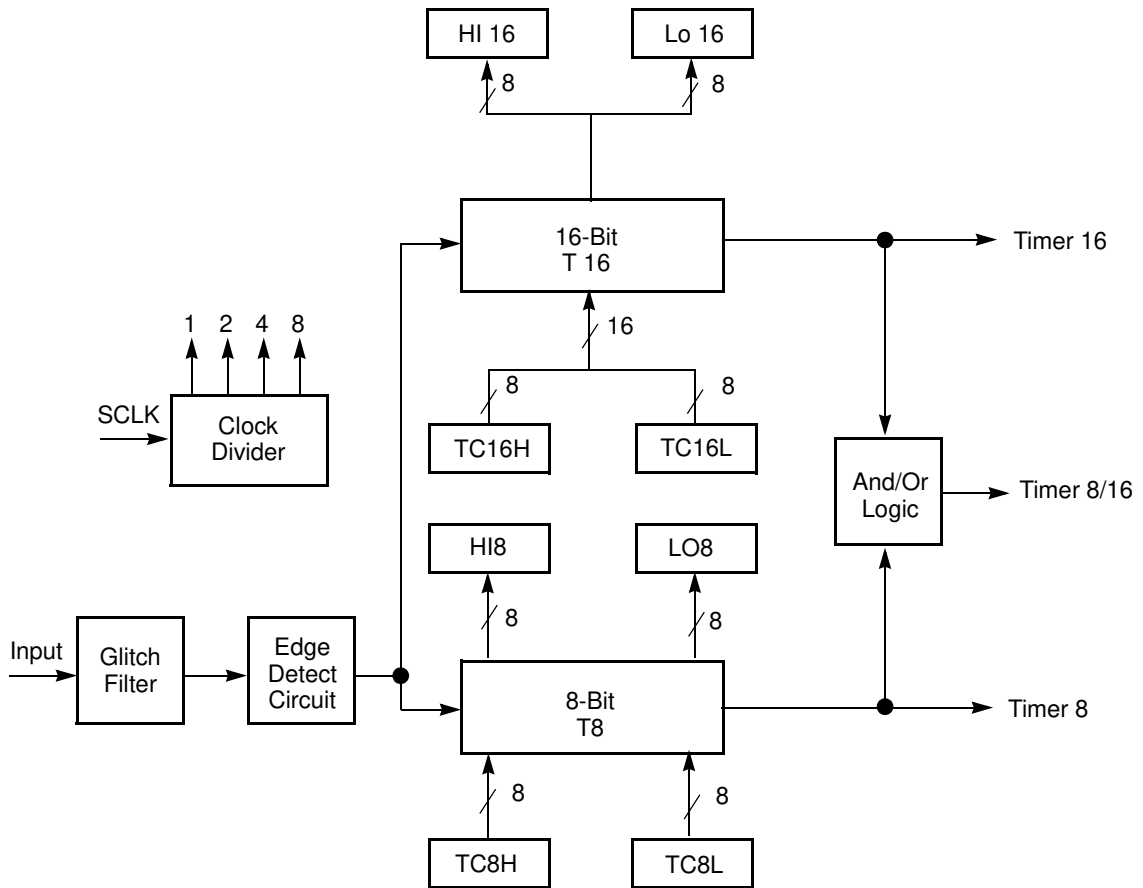

Figure 1. Counter/Timers Diagram

- **Note:** All signals with an overline, “ $\bar{}$ ”, are active Low. For example, $\overline{B/W}$, in which WORD is active Low, and $\overline{B/W}$, in which BYTE is active Low.

Figure 2 shows the functional block diagram.

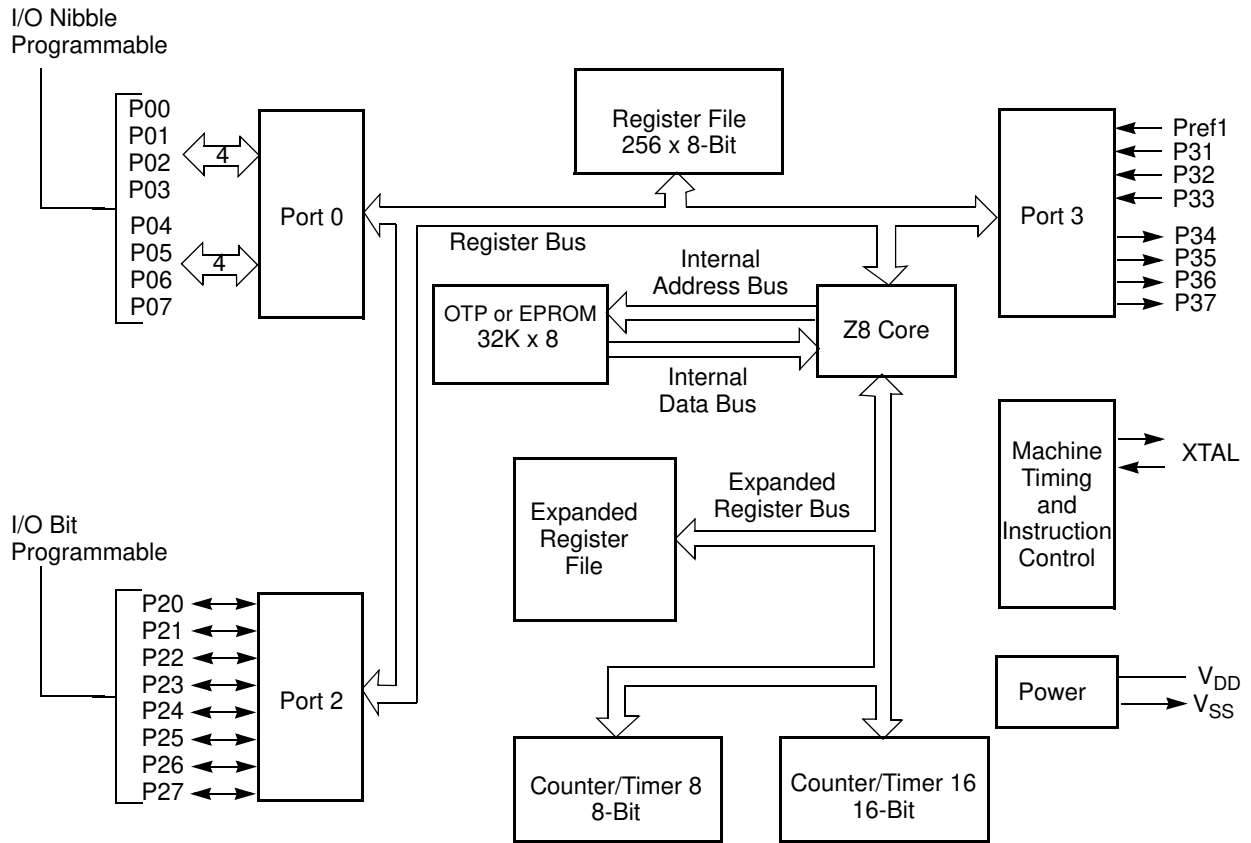

Figure 2. Functional Block Diagram

Pin Description

Figure 3 shows the pin assignment for the 28-pin dual in-line package (DIP)/small outline integrated circuit (SOIC). Table 2 identifies the pins.

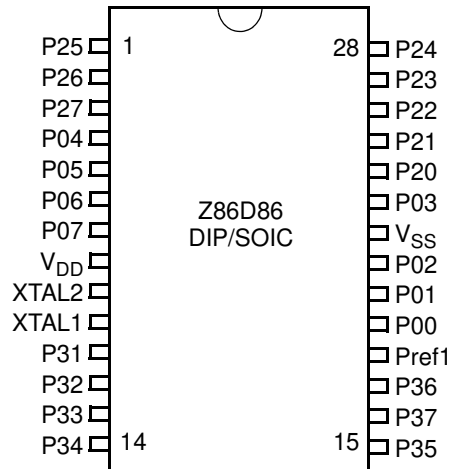

Figure 3. 28-Pin DIP/SOIC Pin Assignment

Table 2. 28-Pin DIP and SOIC Pin Identification

28-Pin DIP and SOIC	Standard Mode	Direction	Description
19	P00	Input/Output	Port 0 is nibble programmable.
20	P01	Input/Output	Port 0–3 can be configured as a
21	P02	Input/Output	mouse/trackball input.
23	P03	Input/Output	
4	P04	Input/Output	
5	P05	Input/Output	
6	P06	Input/Output	
7	P07	Input/Output	
24	P20	Input/Output	Port 2 pins are individually
25	P21	Input/Output	configurable as input or output.
26	P22	Input/Output	
27	P23	Input/Output	
28	P24	Input/Output	
1	P25	Input/Output	
2	P26	Input/Output	
3	P27	Input/Output	



Table 2. 28-Pin DIP and SOIC Pin Identification (Continued)

28-Pin DIP and SOIC	Standard Mode	Direction	Description
18	Pref1	Input	Analog ref input (must be pulled high externally, if not used)
11	P31	Input	IRQ2/modulator input
12	P32	Input	IRQ0
13	P33	Input	IRQ1
14	P34	Output	T8 output
15	P35	Output	T16 output
17	P36	Output	T8/T16 output
16	P37	Output	
10	XTAL1	Input	Crystal, oscillator clock
9	XTAL2	Output	Crystal, oscillator clock
8	V _{DD}		Power supply
22	V _{SS}		Ground

Absolute Maximum Ratings

Table 3 lists the absolute maximum ratings for the Z86D86 microcontroller.

Table 3. Absolute Maximum Ratings

Symbol	Description	Min	Max	Units
V _{MAX}	Supply Voltage (*)	-0.3	+7.0	V
T _{STG}	Storage Temperature	-65°	+150°	C
T _A	Oper. Ambient Temperature	0°	70°	C

Notes:

* Voltage on all pins with respect to GND

Stresses greater than those listed under Absolute Maximum Ratings may cause permanent damage to the device. This rating is a stress rating only. Functional operation of the device at any condition above those indicated in the operational sections of these specifications is not implied. Exposure to absolute maximum rating conditions for an extended period may affect device reliability.

Standard Test Conditions

The characteristics listed below apply for standard test conditions as noted. All voltages are referenced to GND. Positive current flows into the referenced pin (see Figure 4).

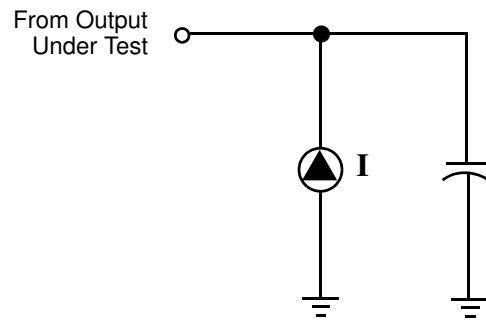

Figure 4. Test Load Diagram

Capacitance

Table 4 lists the capacitance for the Z86D86 microcontroller.

Table 4. Capacitance

Parameter	Max
Input capacitance	12 pF
Output capacitance	12 pF
I/O capacitance	12 pF

Note: $T_A = 25\text{ }^\circ\text{C}$, $V_{CC} = \text{GND} = 0\text{ V}$, $f = 1.0\text{ MHz}$, unmeasured pins returned to GND.

DC Characteristics

Table 5 lists the direct current (DC) characteristics.

Table 5. DC Characteristics

Symbol	Parameter	$T_A = 0\text{ }^{\circ}\text{C to }+70\text{ }^{\circ}\text{C}$			Units	Conditions	Notes
		V_{CC}	Min	Max			
V_{CH}	Clock Input High Voltage	2.3 V	$0.8 V_{CC}$	$V_{CC} + 0.3$	V	Driven by External Clock Generator	
		5.5 V	$0.8 V_{CC}$	$V_{CC} + 0.3$	V	Driven by External Clock Generator	
V_{CL}	Clock Input Low Voltage	2.3 V	$V_{SS}-0.3$	$0.2 V_{CC}$	V	Driven by External Clock Generator	
		5.5 V	$V_{SS}-0.3$	$0.2 V_{CC}$	V	Driven by External Clock Generator	
V_{IH}	Input High Voltage	2.3 V	$0.7 V_{CC}$	$V_{CC} + 0.3$	V		
		5.5 V	$0.7 V_{CC}$	$V_{CC} + 0.3$	V		
V_{IL}	Input Low Voltage	2.3 V	$V_{SS}-0.3$	$0.2 V_{CC}$	V		
		5.5 V	$V_{SS}-0.3$	$0.2 V_{CC}$	V		
V_{OH1}	Output High Voltage	2.3 V	$V_{CC}-0.4$		V	$I_{OH} = -0.5\text{ mA}$	
		5.5 V	$V_{CC}-0.4$		V	$I_{OH} = -0.5\text{ mA}$	
V_{OH2}	Output High Voltage (P36, P37, P00, and P01)	2.3 V	$V_{CC}-0.8$		V	$I_{OH} = -7\text{ mA}$	
		5.5 V	$V_{CC}-0.8$		V	$I_{OH} = -7\text{ mA}$	
V_{OL1}	Output Low Voltage	2.3 V		0.4	V	$I_{OL} = 1.0\text{ mA}$	
		5.5 V		0.4	V	$I_{OL} = 4.0\text{ mA}$	
V_{OL2}	Output Low Voltage	2.3 V		0.8	V	$I_{OL} = 5.0\text{ mA}$	1
		5.5 V		0.8	V	$I_{OL} = 7.0\text{ mA}$	1
V_{OL2}	Output Low Voltage (P00, P01, P36, and P37)	2.3 V		0.8	V	$I_{OL} = 10\text{ mA}$	
		5.5 V		0.8	V	$I_{OL} = 10\text{ mA}$	
V_{OFFSET}	Comparator Input Offset Voltage	2.3 V		25	mV		
		5.5 V		25	mV		
V_{REF}	Comparator Reference Voltage	2.3 V	0	$V_{CC}-1.75$	V		
		5.5 V	0	$V_{CC}-1.75$	V		
I_{IL}	Input Leakage	2.3 V	-1	1	μA	$V_{IN} = 0\text{V}, V_{CC}$	
		5.5 V	-1	1	μA	$V_{IN} = 0\text{V}, V_{CC}$	
I_{OL}	Output Leakage	2.3 V	-1	1	μA	$V_{IN} = 0\text{V}, V_{CC}$	
		5.5 V	-1	1	μA	$V_{IN} = 0\text{V}, V_{CC}$	

Table 5. DC Characteristics (Continued)

Symbol	Parameter	$T_A = 0\text{ }^\circ\text{C to }+70\text{ }^\circ\text{C}$		Units	Conditions	Notes	
		V_{CC}	Min Max				
I_{CC}	Supply Current	2.3 V	10	mA	@ 8.0 MHz	2, 3	
		5.5 V	15	mA	@ 8.0 MHz	2, 3	
		2.3 V	250	μA	@ 32 kHz	2, 3, 4	
		5.5 V	850	μA	@ 32 kHz	2, 3, 4	
I_{CC1}	Standby Current (HALT Mode)	2.3 V	3	mA	$V_{IN} = 0_V$, V_{CC} @ 8.0 MHz	2, 3	
		5.5 V	5	mA	Same as above	2, 3	
		2.3 V	2	mA	Clock Divide-by-16 @ 8.0 MHz	2, 3	
		5.5 V	4	mA	Same as above	2, 3	
I_{CC2}	Standby Current (STOP Mode)	2.3 V	8	μA	$V_{IN} = 0_V$, V_{CC} WDT is not running	5, 6, 9	
		5.5 V	10	μA	Same as above	5, 6, 9	
		2.3 V	500	μA	$V_{IN} = 0_V$, V_{CC} WDT is running	5, 6, 9	
		5.5 V	800	μA	Same as above	5, 6, 9	
I_{LV}	Standby Current (Low Voltage)		100	μA	$V_{CC} < V_{LV}$	7	
T_{POR}	Power-On Reset	2.3 V	12	75	ms		
		5.5 V	5	20	ms		
V_{LV}	Low Voltage Protection		2	2.3	V	8 MHz max Ext. CLK Freq.	8
V_{LB}	Low Battery Detection Flag		2.4	2.7	V	$V_{LB} = V_{LV} + 0.4\text{ V}$	

Notes:

1. All outputs excluding P00, P01, P36, and P37
2. All outputs unloaded, inputs at rail
3. $CL1 = CL2 = 100\text{ pF}$
4. 32 kHz clock driver input
5. V_{LV} increases as the temperature decreases; inputs at V_{CC}
6. Oscillator stopped
7. Oscillator stops when V_{CC} falls below V_{LV} limit.
8. V_{LV} increases as the temperature decreases.
9. WDT, Comparators, Low Voltage Detection, and ADC (if applicable) are disabled. The IC might draw more current if any of the above peripherals is enabled.

AC Characteristics

Figure 5 shows the timing diagram. Table 6 describes the alternating current (AC) characteristics.

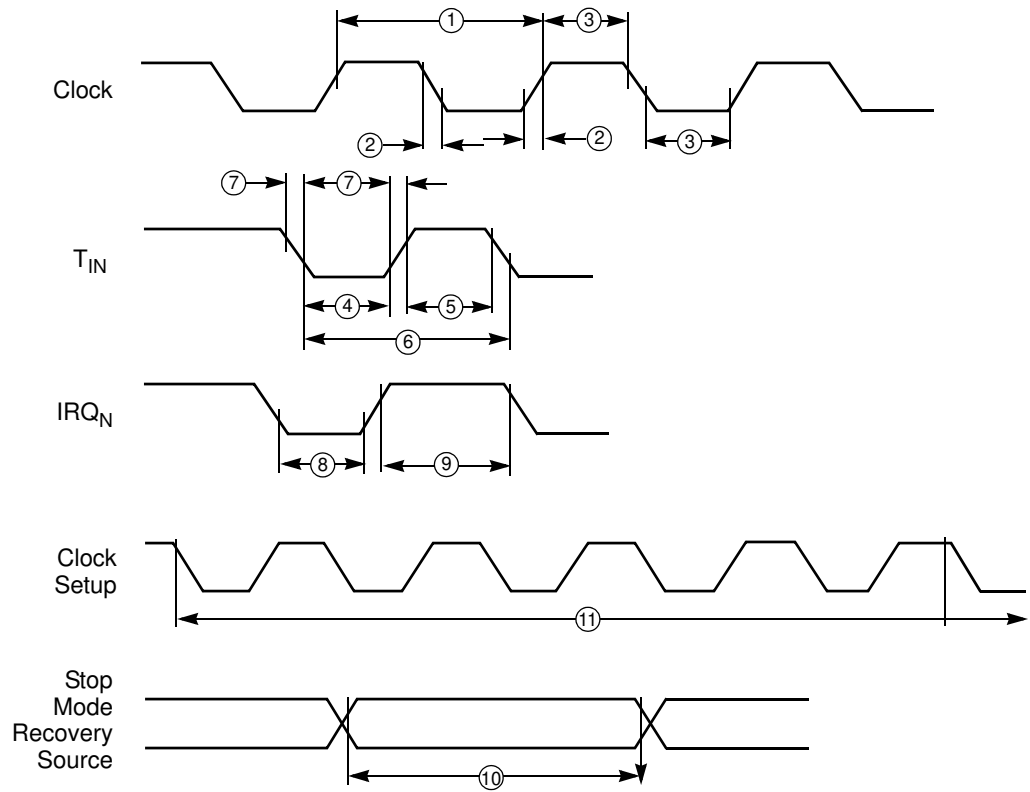

Figure 5. Timing Diagram



Table 6. AC Characteristics

Number	Symbol	Parameter	$T_A = 0^\circ\text{C to } +70^\circ\text{C}$ 8.0 MHz				Notes	Stop-Mode Recovery (D1, D0)
			V_{CC}	Min	Max	Units		
1	TpC	Input Clock Period	2.3 V	121	DC	ns	1	
			5.5 V	121	DC	ns	1	
2	TrC,TfC	Clock Input Rise and Fall Times	2.3 V		25	ns	1	
			5.5 V		25	ns	1	
3	TwC	Input Clock Width	2.3 V	37		ns	1	
			5.5 V	37		ns	1	
4	TwTinL	Timer Input Low Width	2.3 V	100		ns	1	
			5.5 V	70		ns	1	
5	TwTinH	Timer Input High Width	2.3 V	3TpC			1	
			5.5 V	3TpC			1	
6	TpTin	Timer Input Period	2.3 V	8TpC			1	
			5.5 V	8TpC			1	
7	TrTin,TfTin	Timer Input Rise and Fall Times	2.3 V		100	ns	1	
			5.5 V		100	ns	1	
8A	TwIL	Interrupt Request Low Time	2.3 V	100		ns	1, 2	
			5.5 V	70		ns	1, 2	
9	TwIH	Interrupt Request Input High Time	2.3 V	5TpC			1, 2	
			5.5 V	5TpC			1, 2	
10	TwsM	Stop-Mode Recovery Width Spec	2.3 V	12		ns		
			5.5 V	12		ns		
12	Twdt	Watch-Dog Timer Delay Time	2.3 V	12		ms	5	0, 0
			5.5 V	5		ms	5	
			2.3 V	24		ms	5	0, 1
			5.5 V	10		ms	5	
			2.3 V	48		ms	5	1, 0
			5.5 V	20		ms	5	
			2.3 V	192		ms	5	1, 1
			5.5 V	80		ms	5	

Notes:

1. Timing Reference uses 0.9 V_{CC} for a logic 1 and 0.1 V_{CC} for a logic 0.
2. Interrupt request through Port 3 (P33–P31)
3. N/A
4. SMR – D5 = 0.
5. For internal RC oscillator

Pin Functions (Standard Mode)

XTAL1 Crystal 1 (Time-Based Input)

This pin connects a parallel-resonant crystal, ceramic resonator, LC, or RC network to the on-chip oscillator input. An external single-phase clock to the on-chip oscillator input is also an option.

XTAL2 Crystal 2 (Time-Based Output)

This pin connects a parallel-resonant crystal, ceramic resonator, LC, or RC network to the on-chip oscillator output.

Port 0 (P07–P00)

Port 0 is an 8-bit, bidirectional, CMOS-compatible port. These eight I/O lines are configured under software control as a nibble I/O port. The output drivers are push-pull or open drain controlled by bit D2 in the PCON register.

If one or both nibbles are required for I/O operation, they must be configured by writing to the Port 0 mode register. After a hardware reset, Port 0 is configured as an input port.

An EPROM option is available to program 0.4 V_{CC} CMOS trip inputs on P00–P03. This allows direct interface to mouse/trackball IR sensors.

An optional 200 $\pm 50\%$ K Ω s pull-up transistor is available as a mask option on all Port 0 bits with nibble select. See Figure 6.

- **Note:** Internal pull-ups are disabled on any given pin or group of port pins when programmed into output mode.

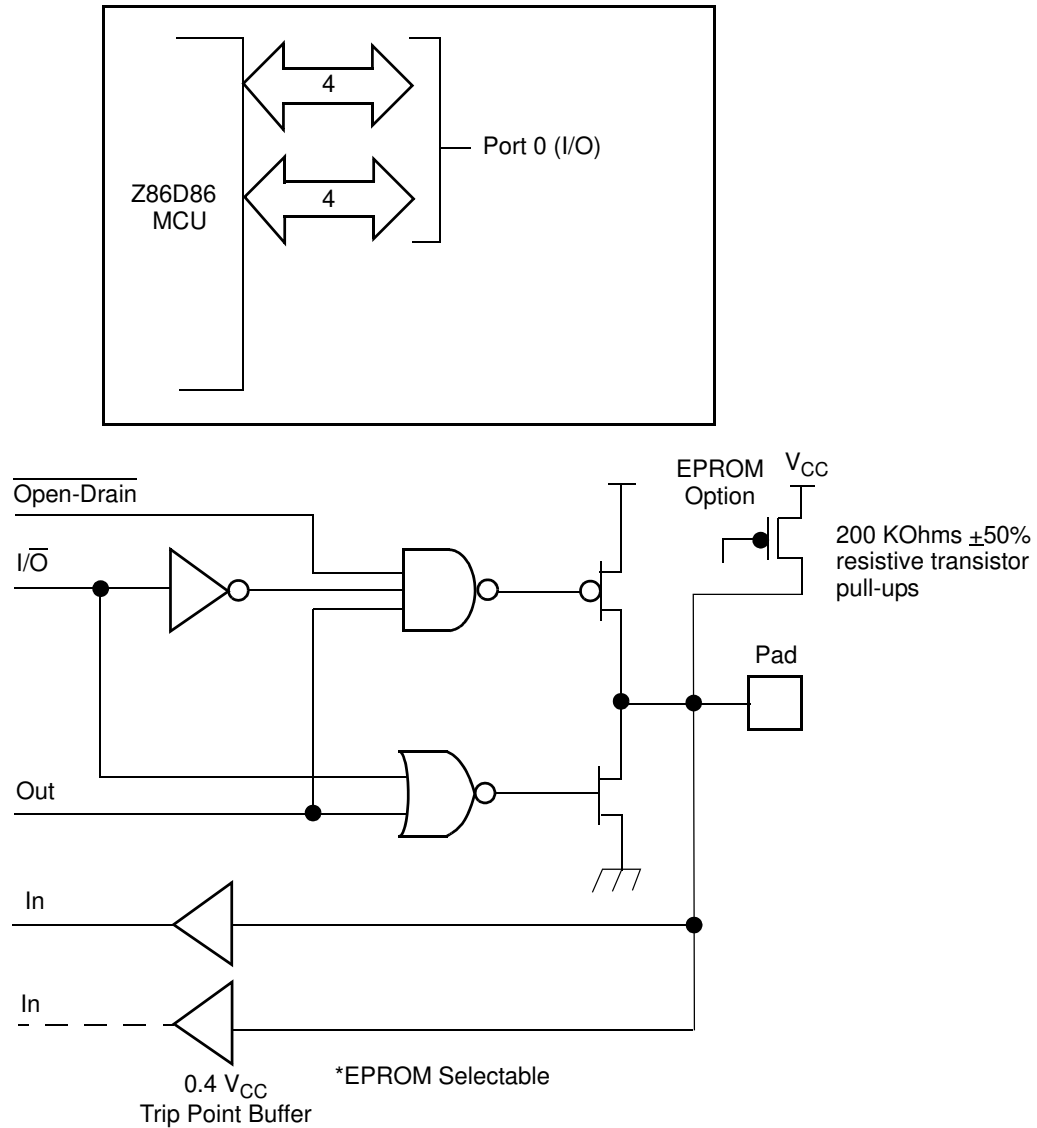

Figure 6. Port 0 Configuration

Port 2 (P27–P20)

Port 2 is an 8-bit, bidirectional, CMOS-compatible I/O port. These eight I/O lines can be independently configured under software control as inputs or outputs. Port 2 is always available for I/O operation. A mask option is available to connect eight 200 KΩ (±50%) pull-up transistors on this port. Bits programmed as outputs are

globally programmed as either push-pull or open-drain. The POR resets with the eight bits of Port 2 configured as inputs.

Port 2 also has an 8-bit input OR and an AND gate, which can be used to wake up the part. P20 can be programmed to access the edge-detection circuitry in demodulation mode. See Figure 7.

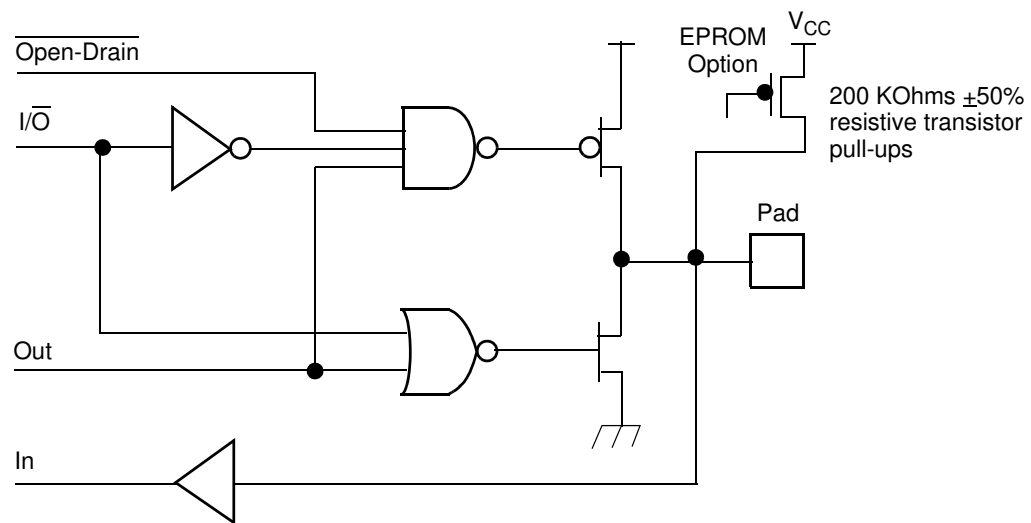
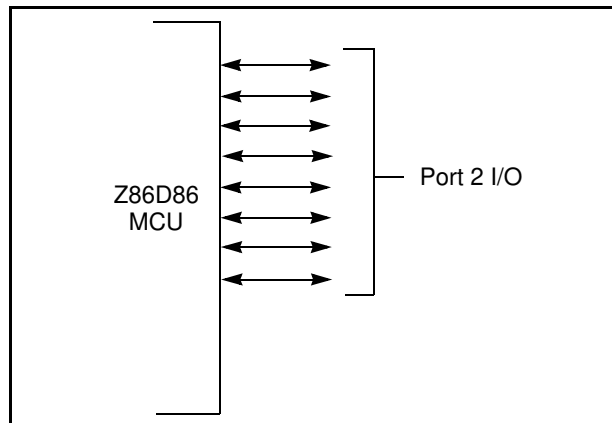

Figure 7. Port 2 Configuration

Port 3 (P37–P31)

Port 3 is a 7-bit, CMOS-compatible fixed I/O port (see Figure 8). Port 3 consists of three fixed input (P33–P31) and four fixed output (P37–P34) ports, and each can be configured under software control for interrupt, and output from the counter/

timers. P31, P32, and P33 are standard CMOS inputs; P34, P35, P36, and P37 are push-pull outputs.

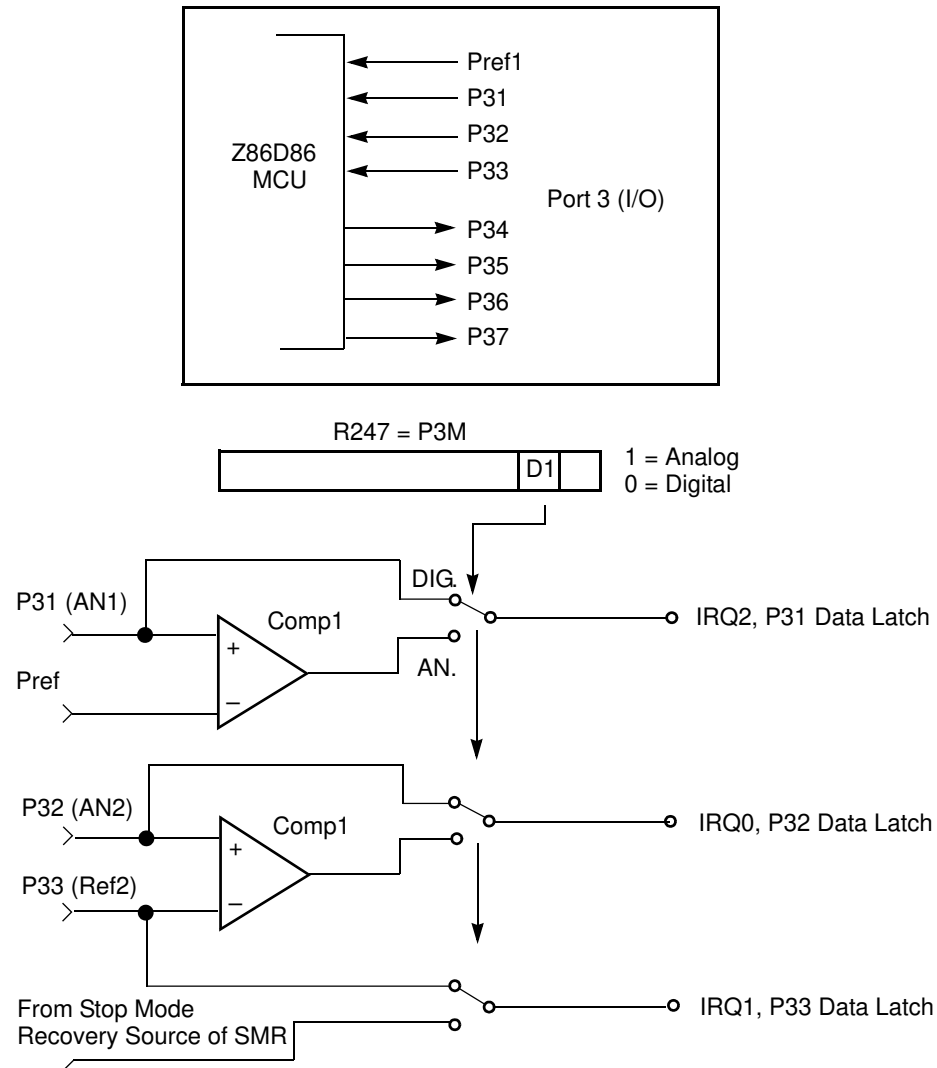

Figure 8. Port 3 Configuration

Two on-board comparators process analog signals on P31 and P32 with reference to the voltage on Pref1 and P33. The analog function is enabled by programming the Port 3 Mode Register (bit 1). P31 and P32 are programmable as rising, falling, or both edge-triggered interrupts (IRQ register bits 6 and 7). Pref1 and P33 are the comparator reference voltage inputs. Access to the counter/timer edge-detection circuit is through P31 or P20 (see “CTR1 Counter/Timer T8 and



T16 Common Control Register” on page 39). Other edge-detect and IRQ modes are described in Table 7.

Table 7. Pin Assignments

Pin	I/O	C/T	Comp.	Int.
Pref1			RF1	
P31	IN	IN	AN1	IRQ2
P32	IN		AN2	IRQ0
P33	IN		RF2	IRQ1
P34	OUT	T8	AO1	
P35	OUT	T16		
P36	OUT	T8/16		
P37	OUT		AO2	
P20	I/O	IN		

Port 3 also provides output for the counter/timers and the AND/OR logic. Control is performed by programming bits D5–D4 of CTR1 and bit 0 of CTR2.

Comparator Inputs

In analog mode, P31 and P32 have a comparator front end. The comparator reference is supplied to P33 and Pref1. In this mode, the P33 internal data latch and its corresponding IRQ1 are diverted to the SMR sources (excluding P31, P32, and P33) as indicated in Figure 8 on page 15. In digital mode, P33 is used as D3 of the Port 3 input register, which then generates IRQ1.

- ▶ **Note:** Comparators are powered down by entering STOP Mode. For P31–P33 to be used in a Stop-Mode Recovery source, these inputs must be placed into digital mode.

Comparator Outputs

These outputs can be programmed to output on P34 and P37 through the PCON register (Figure 9).

Functional Description

The Z86D86 incorporates special functions to enhance the Z8's functionality in consumer and battery-operated applications.

Program Memory

The Z86D86 family addresses 32 KB of internal program memory. The first twelve bytes are reserved for interrupt vectors. These locations contain the five 16-bit vectors that correspond to the five available interrupts.

RAM

The Z86D86 device has 237 bytes of RAM that make up the register file.

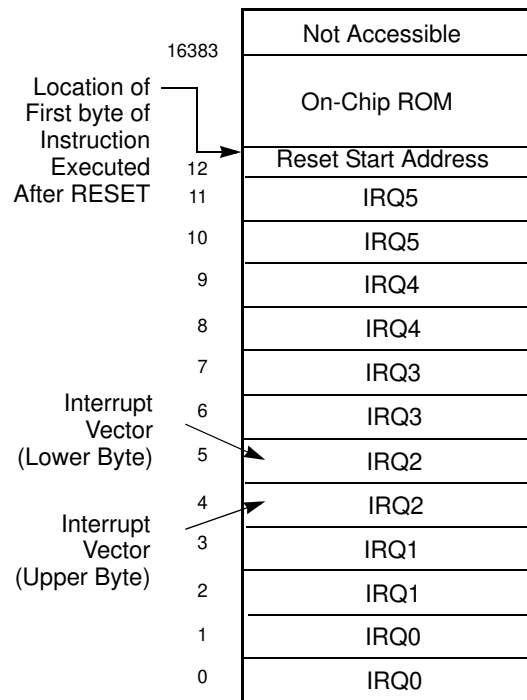

Figure 10. Program Memory Map (32K ROM)

Expanded Register File

The register file has been expanded to allow for additional system control registers and for mapping of additional peripheral devices into the register address area. The Z8 register address space R0 through R15 has been implemented as



16 banks, with 16 registers per bank. These register groups are known as the ERF (Expanded Register File). Bits 7–4 of register RP select the working register group. Bits 3–0 of register RP select the expanded register file bank.

► **Note:** An expanded register bank is also referred to as an expanded register group (see Figure 11).

The upper nibble of the register pointer (Figure 12 on page 21) selects which working register group, of 16 bytes in the register file, is accessed out of the possible 256. The lower nibble selects the expanded register file bank and, in the case of the Z86D86 family, banks 0, F, and D are implemented. A 0h in the lower nibble allows the normal register file (bank 0) to be addressed, but any other value from 1h to Fh exchanges the lower 16 registers to an expanded register bank. For example, for the Z86D86 (see Figure 11):

```
R253 RP = 00h
      R0 = Port 0
      R1 = Port 1
      R2 = Port 2
      R3 = Port 3
```

But if:

```
R253 RP = 0Dh
      R0 = CTRL0
      R1 = CTRL1
      R2 = CTRL2
      R3 = Reserved
```

The counter/timers are mapped into ERF group D. Access is easily performed using the following:

```
LD      RP, #0Dh      ; Select ERF D for access to bank D
                          ; (working register group 0)
LD      R0, #xx       ; load CTRL0
LD      1, #xx        ; load CTRL1
LD      R1, 2         ; CTRL2→CTRL1

LD      RP, #0Dh      ; Select ERF D for access to bank D
                          ; (working register group 0)
LD      RP, #7Dh      ; Select expanded register bank D
                          ; working register group 7 of bank 0
                          ; for access.
LD      71h, 2        ; CTRL2→register 71h
LD      R1, 2         ; CTRL2→register 71h
```

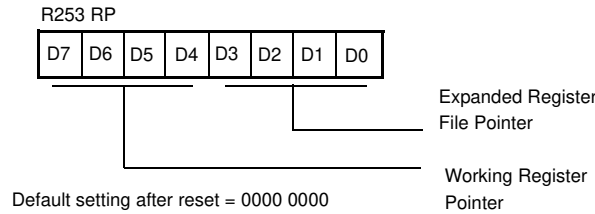



Figure 12. Register Pointer Register

Expanded Register File Control Registers (0D)

Figure 13, Figure 14, Figure 15, and Figure 16 show the expanded register file control registers (0D).

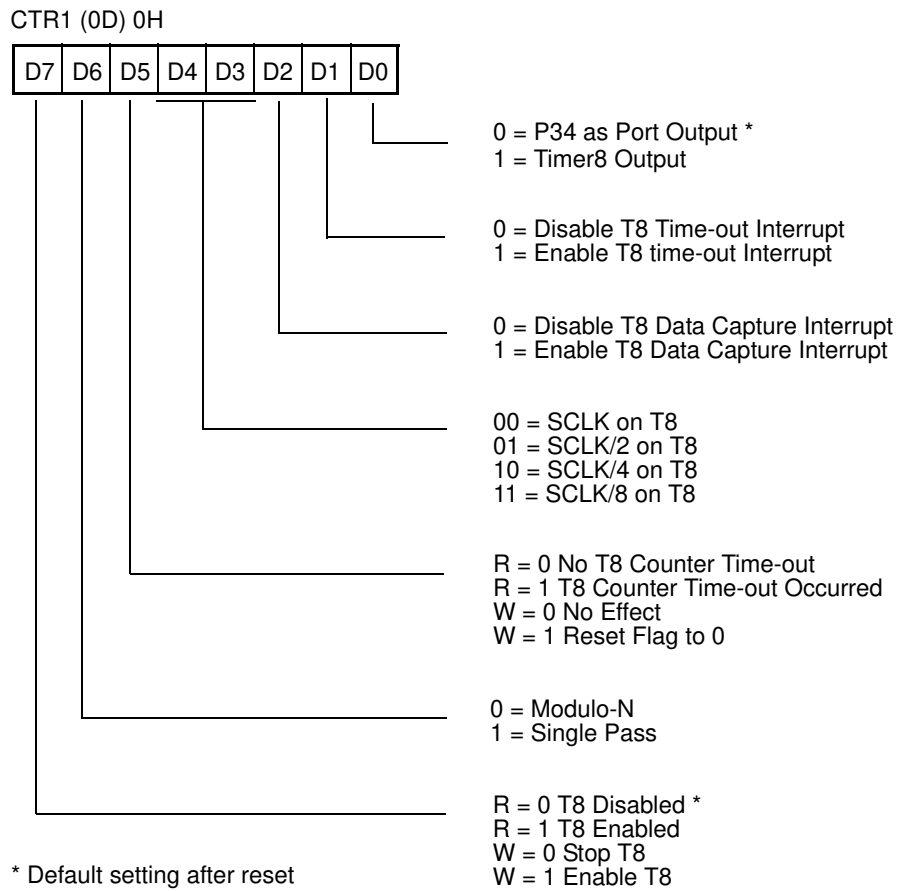
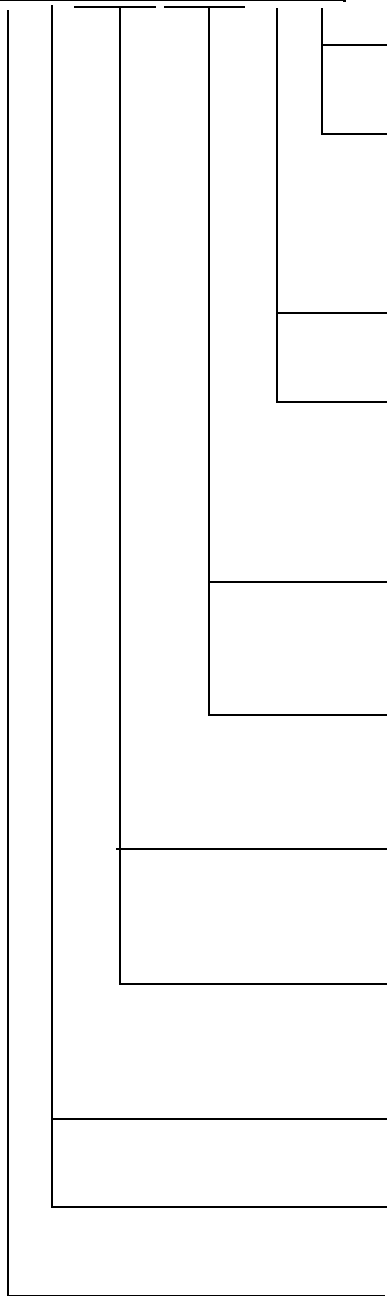
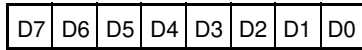

Figure 13. TC8 Control Register—(0D) 0H: Read/Write Except Where Noted

CTR1 (0D) 1H



- Transmit Mode
R/W 0 Reserved
1 Reserved
- Demodulation Mode
R 0 = No Falling Edge Detection
R 1 = Falling Edge Detection

W 0 = No Effect
W 1 = Reset Flag to 0
- Transmit Mode
R/W 0 = T8_OUT is 0 initially
R/W 1 = T8_OUT is 1 initially
- Demodulation Mode
R 0 = No Rising Edge Detection
R 1 = Rising Edge Detection

W 0 = No Effect
W 1 = Reset flag to 0
- Transmit Mode
0 0 = Normal Operation
0 1 = Ping-Pong Mode
1 0 T16_OUT = 0
1 1 T16_OUT = 1
- Demodulation Mode
0 0 = No Filter
0 1 = 4 SCLK Cycle Filter
1 0 = 8 SCLK Cycle Filter
1 1 = Reserved
- Transmit Mode/T8/T16 Logic
0 0 = AND
0 1 = OR
1 0 = NOR
1 1 = NAND
- Demodulation Mode
0 0 = Falling Edge Detection
0 1 = Rising Edge Detection
1 0 = Both Edge Detection
1 1 = Reserved
- Transmit Mode
0 = P36 as Port Output *
1 = P36 as T8/T16_OUT
- Demodulation Mode
0 = P31 as Demodulator Input
1 = P20 as Demodulator Input
- Transmit/Demodulation Modes
0 = Transmit Mode *
1 = Demodulation Mode

Note: Care must be taken in differentiating transmit mode from demodulation mode. Depending on which of these two modes is operating, the CTR1 bit has different functions.

Note: Changing from one mode to another cannot be done without disabling the counter/timers.

* Default setting after reset

Figure 14. T8 and T16 Common Control Functions—(0D) 1H: Read/Write

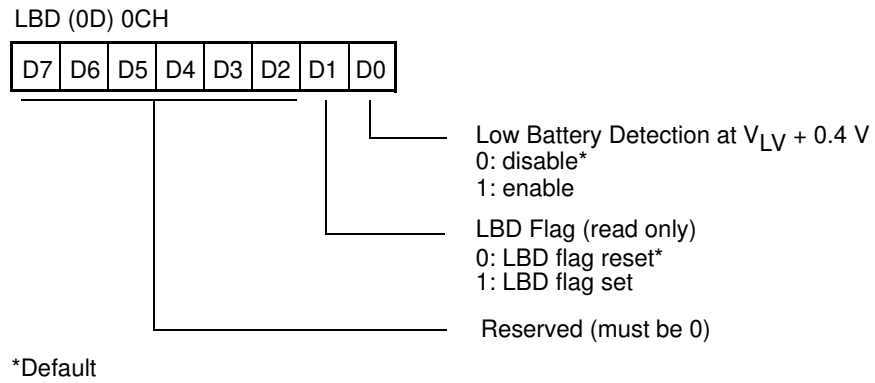
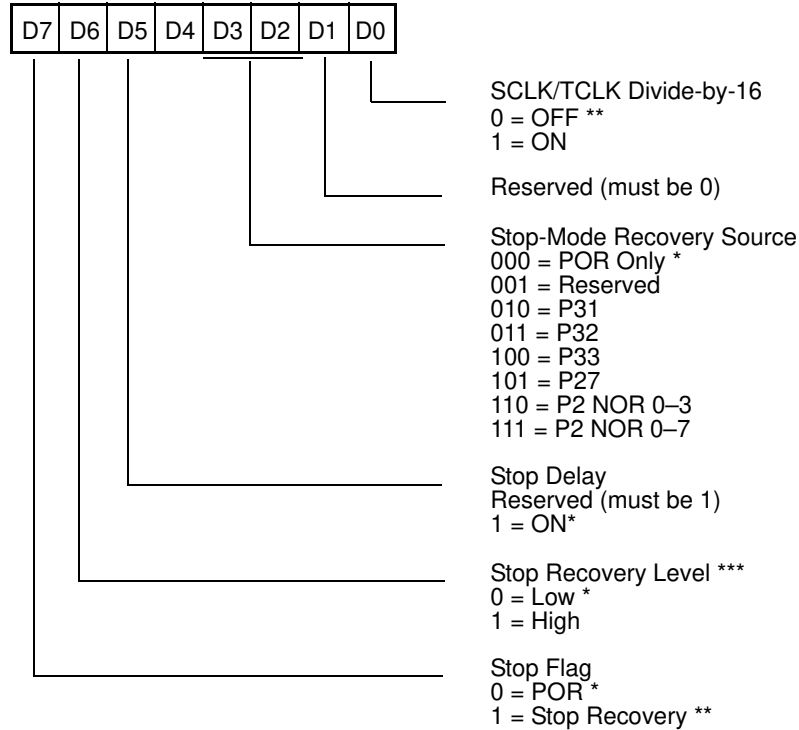

Figure 16. Low Battery Detection

Expanded Register File Control Registers (0F)

Figure 17 through Figure 30 show the expanded register file control registers (0F).

SMR (0F) 0B



* Default setting after reset
 ** Default setting after reset and Stop-Mode Recovery
 *** At the XOR gate input

Figure 17. Stop-Mode Recovery Register—(0F) 0BH: D6–D0 = Write Only, D7 = Read Only

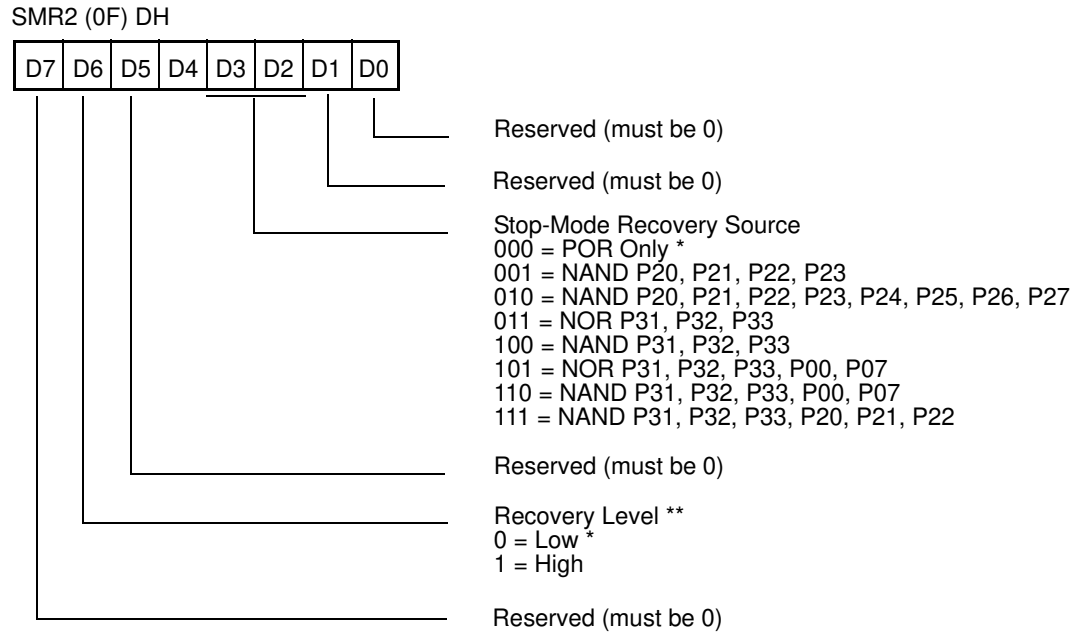

* Default setting after reset
** At the XOR gate input

Note: If used in conjunction with SMR,
either of the two specified events
causes a Stop-Mode Recovery.

Figure 18. Stop-Mode Recovery Register 2—(0F) 0DH: D2–D4, D6 Write Only

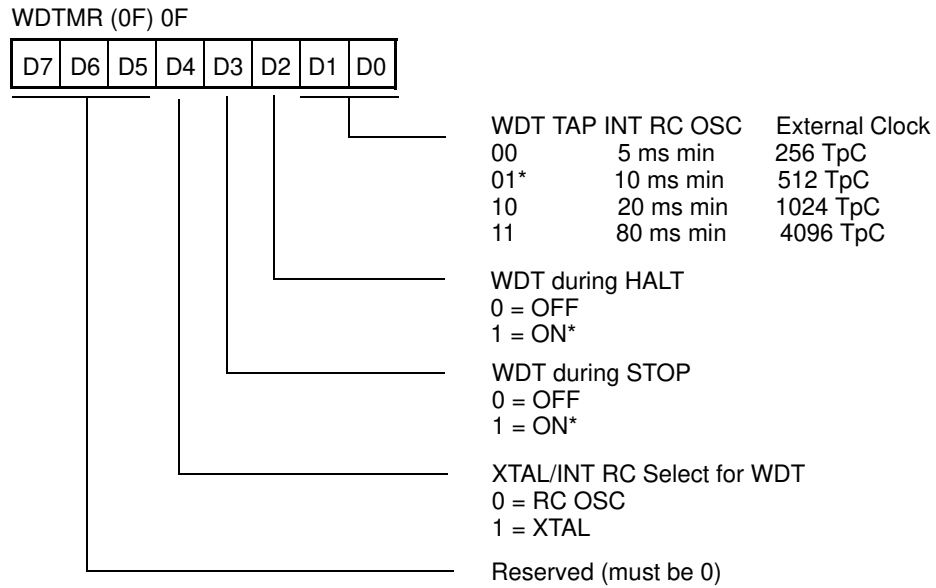

* Default setting after reset

Figure 19. Watch-Dog Timer Register—(0F) 0FH: Write Only

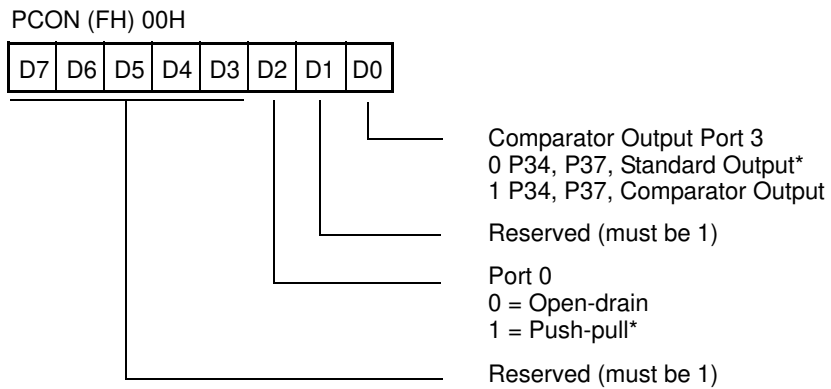

*Default setting after reset

Figure 20. Port Configuration Register (PCON)—(0F) 0H: Write Only

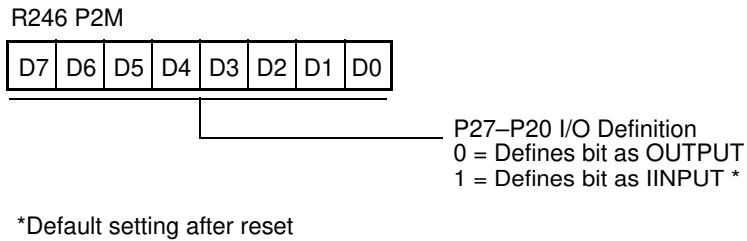

Figure 21. Port 2 Mode Register—F6H: Write Only

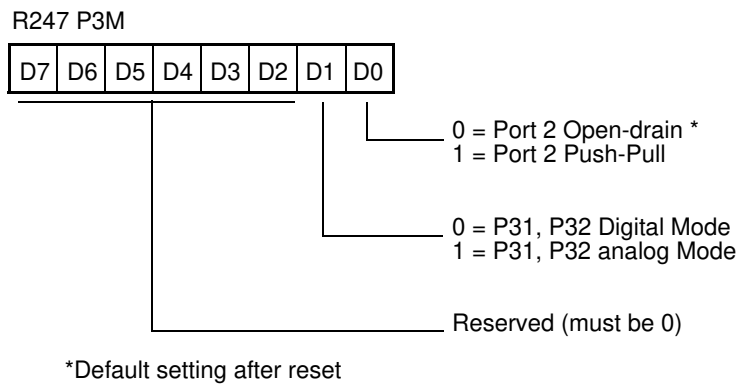
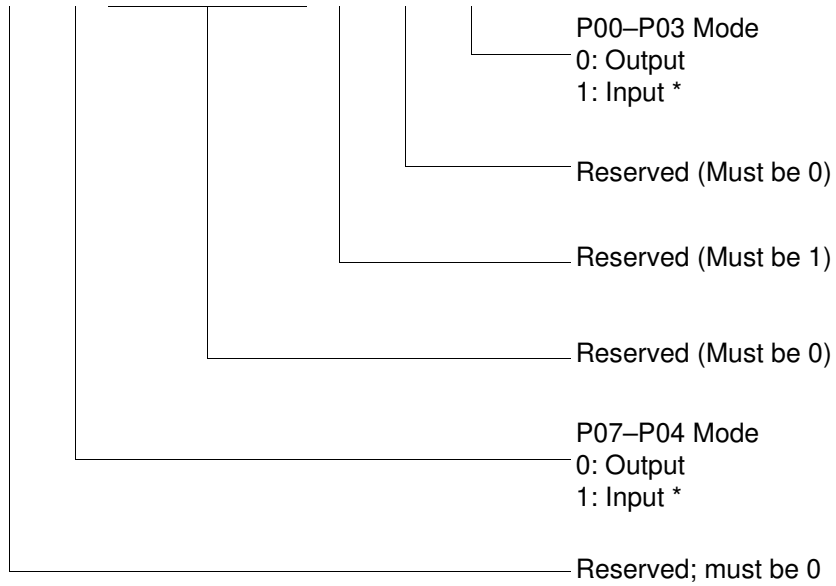

Figure 22. Port 3 Mode Register—F7H: Write Only

R248 P01M

D7	D6	D5	D4	D3	D2	D1	D0
----	----	----	----	----	----	----	----



* Default setting after reset; only P00, P01 and P07 are available on 20-pin configurations.

Figure 23. Port 0 and 1 Mode Register—F8H: Write Only

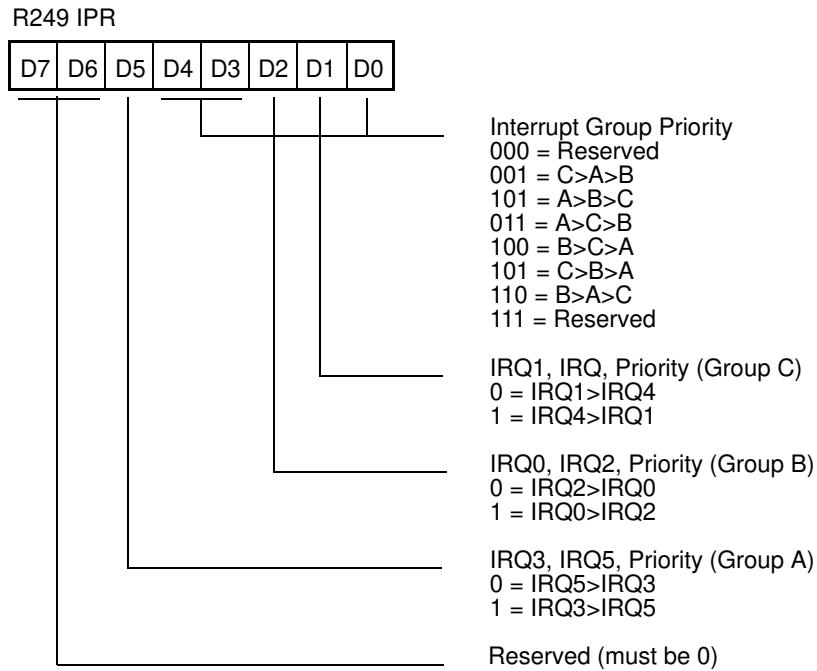

Figure 24. Interrupt Priority Register—F9H: Write Only

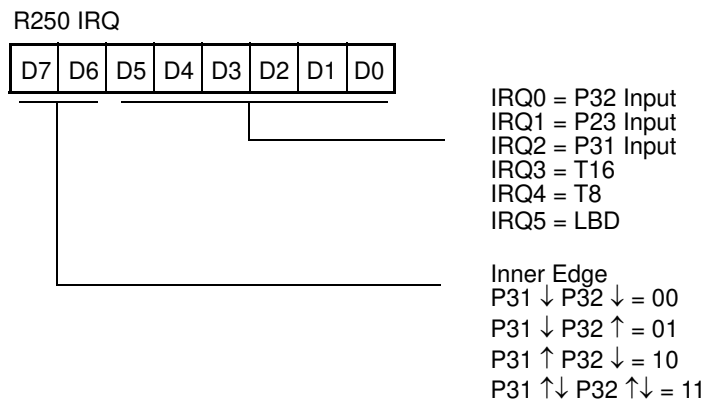
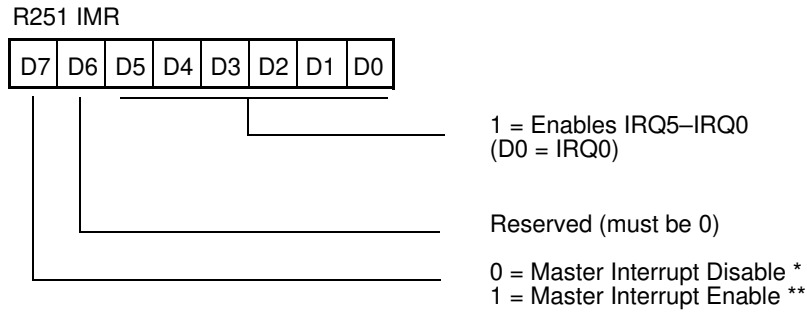

Figure 25. Interrupt Request Register—FAH: Read/Write



* Default setting after reset

** Only by using E1, D1 instruction. D1 is required before changing the IMR register.

Figure 26. Interrupt Mask Register—FBH: Read/Write

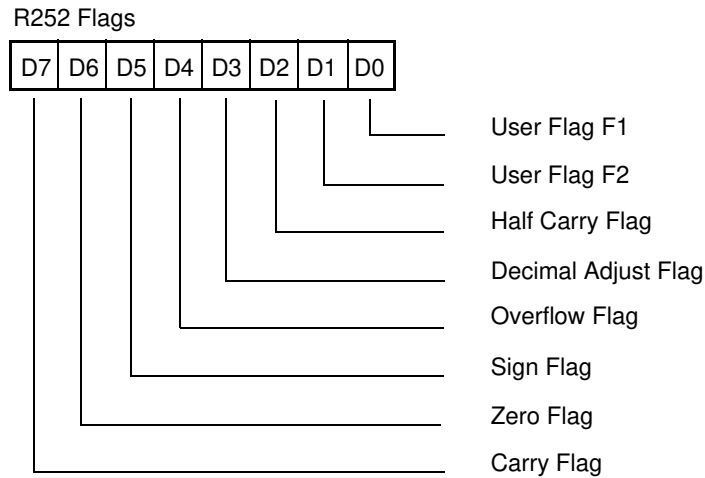

Figure 27. Flag Register—FCH: Read/Write

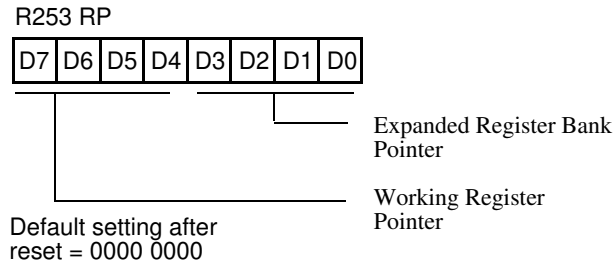

Figure 28. Register Pointer—FDH: Read/Write

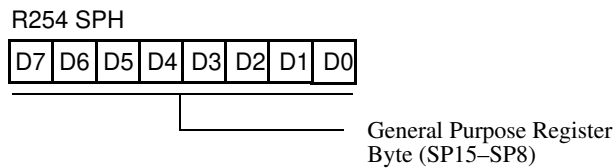

Figure 29. Stack Pointer High—FEH: Read/Write

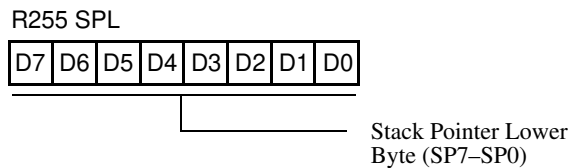

Figure 30. Stack Pointer Low—FFH: Read/Write

Register File

The register file (bank 0) consists of four I/O port registers, 237 general-purpose registers, and 16 control and status registers (R0–R3, R4–R239, and R240–255, respectively). Additional, there are two expanded registers groups in Banks D and F. Instructions can access registers directly or indirectly through an 8-bit address field, thereby allowing a short, 4-bit register address to use the Register Pointer (Figure 31). In the 4-bit mode, the register file is divided into 16 working register groups, each occupying 16 continuous locations. The Register Pointer addresses the starting location of the active working register group.

- **Note:** Working register group E0–EF can only be accessed through working registers and indirect addressing modes.

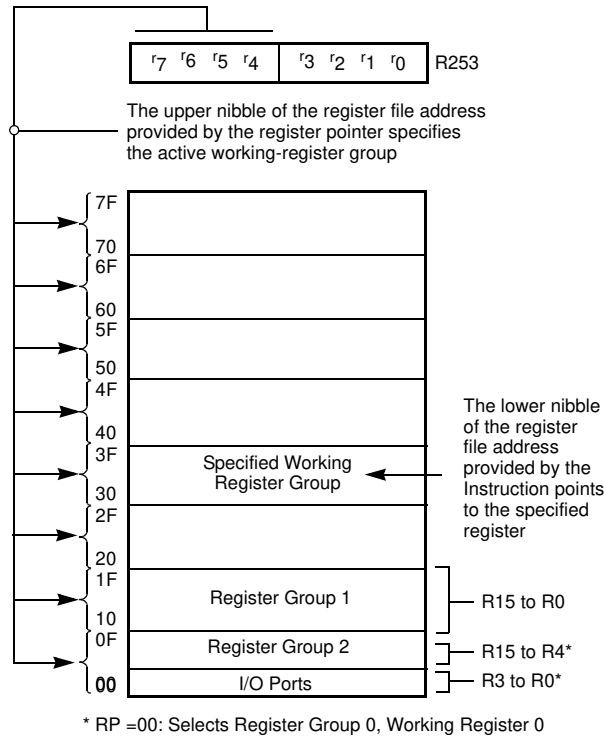

Figure 31. Register Pointer

Stack

The Z86D86 internal register file is used for the stack. An 8-bit Stack Pointer (R255) is used for the internal stack that resides in the general-purpose registers (R4–R239). SPH is used as a general-purpose register only when using internal stacks.

- **Note:** When SPH is used as a general-purpose register and Port 0 is in address mode, the contents of SPH are loaded into Port 0 whenever the internal stack is accessed.



Counter/Timer Registers

Table 8 describes the expanded register group D.

Table 8. Expanded Register Group D

(D)0Ch	LVD
(D)0Bh	HI8
(D)0Ah	LO8
(D)09h	HI16
(D)08h	LO16
(D)07h	TC16H
(D)06h	TC16L
(D)05h	TC8H
(D)04h	TC8L
(D)03h	Reserved
(D)02h	CTR2
(D)01h	CTR1
(D)00h	CTR0

Register Description

LBD(D)0Ch—Low Battery Detection Register

Bit 0 enables/disables the Low Battery Detection Circuit. Bit 1 flags if low battery is detected. Interrupt 5 is triggered when the flag bit is set, given that IRQ5 is not masked. See Table 9.

- ▶ **Note:** The LVD flag will be valid after enabling the detection for 20 μ S (design estimation, not tested in production). LVD does not work at STOP mode. It must be disabled during STOP mode in order to reduce current.



Table 9. LBD(D)0C—Low Battery Detection Register

Field	Bit Position			Description
LBD	765432--			Reserved No effect
	-----1-	R	1	LB flag set
			0*	LB flag reset
	-----0	R/W	1	Enable LBD
			0*	Disable LBD

Note:

*Default after POR

HI8(D)0Bh

This register (Table 10) holds the captured data from the output of the 8-bit Counter/Timer0. This register is typically used to hold the number of counts when the input signal is 1.

Table 10. HI8(D)0Bh

Field	Bit Position			Description
T8_Capture_HI	76543210	R		Captured Data
		W		No Effect

L08(D)0Ah

This register (Table 11) holds the captured data from the output of the 8-bit Counter/Timer0. This register is typically used to hold the number of counts when the input signal is 0.

Table 11. L08(D)0Ah

Field	Bit Position			Description
T8_Capture_L0	76543210	R		Captured Data
		W		No Effect

HI16(D)09h

This register (Table 12) holds the captured data from the output of the 16-bit Counter/Timer16. This register holds the MS-Byte of the data.



Table 12. HI16(D)09h

Field	Bit Position		Description
T16_Capture_HI	76543210	R W	Captured Data No Effect

L016(D)08h

This register (Table 13) holds the captured data from the output of the 16-bit Counter/Timer16. This register holds the LS-Byte of the data.

Table 13. L016(D)08h

Field	Bit Position		Description
T16_Capture_LO	76543210	R W	Captured Data No Effect

TC16H(D)07h

Table 14 describes the Counter/Timer2 MS-Byte Hold Register.

Table 14. TC16H(D)07h

Field	Bit Position		Description
T16_Data_HI	76543210	R/W	Data

TC16L(D)06h

Table 15 describes the Counter/Timer2 LS-Byte Hold Register.

Table 15. TC16L(D)06h

Field	Bit Position		Description
T16_Data_LO	76543210	R/W	Data

TC8H(D)05h

Table 16 describes the Counter/Timer8 High Hold Register.



Table 16. TC8H(D)05h

Field	Bit Position	Description	
T8_Level_HI	76543210	R/W	Data

TC8L(D)04h

Table 17 describes the Counter/Timer8 Low Hold Register.

Table 17. TC8L(D)04h

Field	Bit Position	Description	
T8_Level_LO	76543210	R/W	Data

CTR0 Counter/Timer8 Control Register

Table 18 describes the CTR0 (D)00 Counter/Timer8 Control Register.

Table 18. CTR0 (D)00 Counter/Timer8 Control Register

Field	Bit Position		Value	Description
T8_Enable	7-----	R	0*	Counter Disabled
			1	Counter Enabled
		W	0	Stop Counter
			1	Enable Counter
Single/Modulo-N	-6-----	R/W	0	Modulo-N
			1	Single Pass
Time_Out	--5-----	R	0	No Counter Time-Out
			1	Counter Time-Out Occurred
		W	0	No Effect
			1	Reset Flag to 0
T8_Clock	---43---	R/W	0 0	SCLK
			0 1	SCLK/2
			1 0	SCLK/4
			1 1	SCLK/8
Capture_INT_MASK	-----2--	R/W	0	Disable Data Capture Int.
			1	Enable Data Capture Int.



Table 18. CTR0 (D)00 Counter/Timer8 Control Register (Continued)

Field	Bit Position		Value	Description
Counter_INT_Mask	-----1-	R/W	0	Disable Time-Out Int.
			1	Enable Time-Out Int.
P34_Out	-----0	R/W	0*	P34 as Port Output
			1	T8 Output on P34

Note:
* Indicates the value upon Power-On Reset.

T8 Enable

This field enables T8 when set (written) to 1.

Single/Modulo-N

When set to 0 (modulo-n), the counter reloads the initial value when the terminal count is reached. When set to 1 (single pass), the counter stops when the terminal count is reached.

Time-Out

This bit is set when T8 times out (terminal count reached). To reset this bit, a 1 must be written to this location.



Caution: Writing a 1 is the only way to reset the Terminal Count status condition. Therefore, you must reset this bit before using/enabling the counter/timers.

The first clock of T8 might not exhibit complete clock width and can occur anytime when enabled.



Note: Care must be taken when utilizing the OR or AND commands to manipulate CTR0, bit 5 and CTR1, bits 0 and 1 (demodulation mode). These instructions use a Read-Modify-Write sequence in which the current status from the CTR0 and CTR1 registers is ORed or ANDed with the designated value and then written back into the registers.

For example, when the status of bit 5 is 1, a timer reset condition occurs.

T8 Clock

This bit defines the frequency of the input signal to T8.



Capture_INT_Mask

Set this bit to allow an interrupt when data is captured into either LO8 or HI8 upon a positive or negative edge detection in demodulation mode.

Counter_INT_Mask

Set this bit to allow an interrupt when T8 has a time-out.

P34_Out

This bit defines whether P34 is used as a normal output pin or the T8 output.

CTR1 Counter/Timer T8 and T16 Common Control Register

This register controls the functions in common with the T8 and T16. See Table 19.

Table 19. CTR1(D)01h Register

Field	Bit Position	Value	Description
Mode	7-----	R/W 0*	Transmit Mode Demodulation Mode
P36_Out/Demodulator_Input	-6-----	R/W 0* 1 0 1	Transmit Mode Port Output T8/T16 Output Demodulation Mode P31 P20
T8/T16_Logic/Edge_Detect	--54----	R/W 00 01 10 11 00 01 10 11	Transmit Mode AND OR NOR NAND Demodulation Mode Falling Edge Rising Edge Both Edges Reserved



Table 19. CTR1(D)01h Register (Continued)

Field	Bit Position	Value	Description
Transmit_Submode/Glitch_Filter	----32--	R/W	Transmit Mode
		00	Normal Operation
		01	Ping-Pong Mode
		10	T16_Out = 0
		11	T16_Out = 1
			Demodulation Mode
		00	No Filter
		01	4 SCLK Cycle
		10	8 SCLK Cycle
		11	Reserved
Initial_T8_Out/Rising Edge	-----1-	R/W	Transmit Mode
		0	T8_OUT is 0 Initially
		1	T8_OUT is 1 Initially
			Demodulation Mode
		R	No Rising Edge
		1	Rising Edge Detected
		W	No Effect
		1	Reset Flag to 0
Initial_T16_Out/Falling Edge	-----0	R/W	Transmit Mode
		0	T16_OUT is 0 initially.
		1	T16_OUT is 1 initially.
			Demodulation Mode
		R	No Falling Edge
		1	Falling Edge Detected
		W	No Effect
		1	Reset Flag to 0

Note:

*Default upon Power-On Reset

Mode

If it is 0, the counter/timers are in the transmit mode; otherwise, they are in the demodulation mode.

P36_Out/Demodulator_Input

In transmit mode, this bit defines whether P36 is used as a normal output pin or the combined output of T8 and T16.

In demodulation mode, this bit defines whether the input signal to the counter/timers is from P20 or P31.



T8/T16_Logic/Edge _Detect

In transmit mode, this field defines how the outputs of T8 and T16 are combined (AND, OR, NOR, NAND).

In demodulation mode, this field defines which edge needs to be detected by the edge detector.

Transmit_Submode/Glitch Filter

In transmit mode, this field defines whether T8 and T16 are in the “Ping-Pong” mode or in independent normal operation mode. Setting this field to “Normal Operation Mode” terminates the “Ping-Pong Mode” operation. When set to 10, T16 is immediately forced to a 0; a setting of 11 forces T16 to output a 1.

In demodulation mode, this field defines the width of the glitch that needs to be filtered out.

Initial_T8_Out/Rising_Edge

In transmit mode, if 0, the output of T8 is set to 0 when it starts to count. If 1, the output of T8 is set to 1 when it starts to count. When the counter is not enabled and this bit is set to 1 or 0, T8_OUT is set to the opposite state of this bit. This measure ensures that when the clock is enabled, a transition occurs to the initial state set by CTR1, D1.

In demodulation mode, this bit is set to 1 when a rising edge is detected in the input signal. In order to reset it, a 1 must be written to this location.

Initial_T16 Out/Falling _Edge

In transmit mode, if it is 0, the output of T16 is set to 0 when it starts to count. If it is 1, the output of T16 is set to 1 when it starts to count. This bit is effective only in Normal or Ping-Pong Mode (CTR1, D3, D2). When the counter is not enabled and this bit is set, T16_OUT is set to the opposite state of this bit. This measure ensures that when the clock is enabled, a transition occurs to the initial state set by CTR1, D0.

In demodulation mode, this bit is set to 1 when a falling edge is detected in the input signal. In order to reset it, a 1 must be written to this location.

- **Note:** Modifying CTR1 (D1 or D0) while the counters are enabled causes unpredictable output from T8/16_OUT.



CTR2 Counter/Timer16 Control Register

Table 20 describes the contents of the CTR2 register.

Table 20. CTR2 (D)02h: Counter/Timer16 Control Register

Field	Bit Position		Value	Description
T16_Enable	7-----	R	0*	Counter Disabled
			1	Counter Enabled
		W	0	Stop Counter
			1	Enable Counter
Single/Modulo-N	-6-----	R/W	0	Transmit Mode
			1	Modulo-N
				Single Pass
			0	Demodulation Mode
			1	T16 Recognizes Edge T16 Does Not Recognize Edge
Time_Out	--5-----	R	0	No Counter Time-Out
			1	Counter Time-Out Occurred
		W	0	No Effect
			1	Reset Flag to 0
T16_Clock	---43---	R/W	00	SCLK
			01	SCLK/2
			10	SCLK/4
			11	SCLK/8
Capture_INT_Mask	-----2--	R/W	0	Disable Data Capture Int.
			1	Enable Data Capture Int.
Counter_INT_Mask	-----1-	R/W	0	Disable Time-Out Int. Enable Time-Out Int.
P35_Out	-----0	R/W	0*	P35 as Port Output
			1	T16 Output on P35

Note:

* Indicates the value upon Power-On Reset.

T16_Enable

This field enables T16 when set to 1.

Single/Modulo-N

In transmit mode, when this bit is set to 0, the counter reloads the initial value when terminal count is reached. When this bit is set to 1, the counter stops when the terminal count is reached.



In demodulation mode, when this bit is set to 0, T16 captures and reloads on detection of all the edges. When this bit is set to 1, T16 captures and detects on the first edge, but ignores the subsequent edges. For details, see “T16 Demodulation Mode” on page 51.

Time_Out

This bit is set when T16 times out (terminal count reached). In order to reset this bit, a 1 must be written to this location.

T16_Clock

This bit defines the frequency of the input signal to Counter/Timer16.

Capture_INT_Mask

This bit is set to allow an interrupt when data is captured into LO16 and HI16.

Counter_INT_Mask

This bit is set to allow an interrupt when T16 times out.

P35_Out

This bit defines whether P35 is used as a normal output pin or T16 output.

Counter/Timer Functional Blocks

The following are the counter/timer functional blocks:

- Input circuit
- Eight-bit counter/timer circuits (page 44)
- Sixteen-bit counter/timer circuits (page 50)
- Output circuit (page 54)

Input Circuit

The edge detector monitors the input signal on P31 or P20. Based on CTR1 D5–D4, a pulse is generated at the Pos Edge or Neg Edge line when an edge is detected. Glitches in the input signal that have a width less than specified (CTR1 D3, D2) are filtered out (see Figure 32).

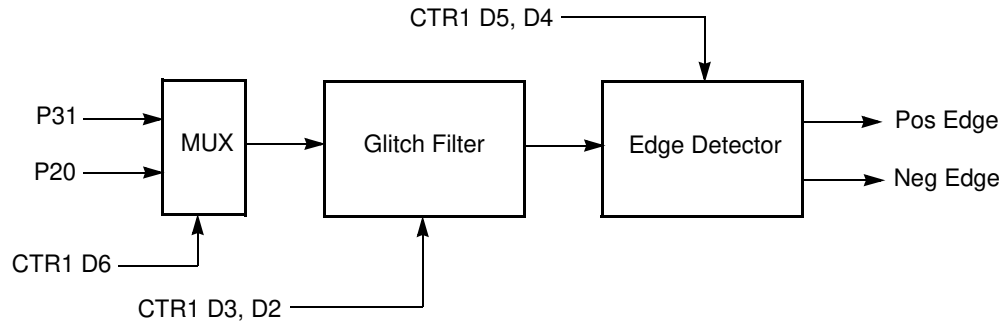

Figure 32. Glitch Filter Circuitry

Eight-Bit Counter/Timer Circuits

Figure 33 shows the 8-bit counter/timer circuits.

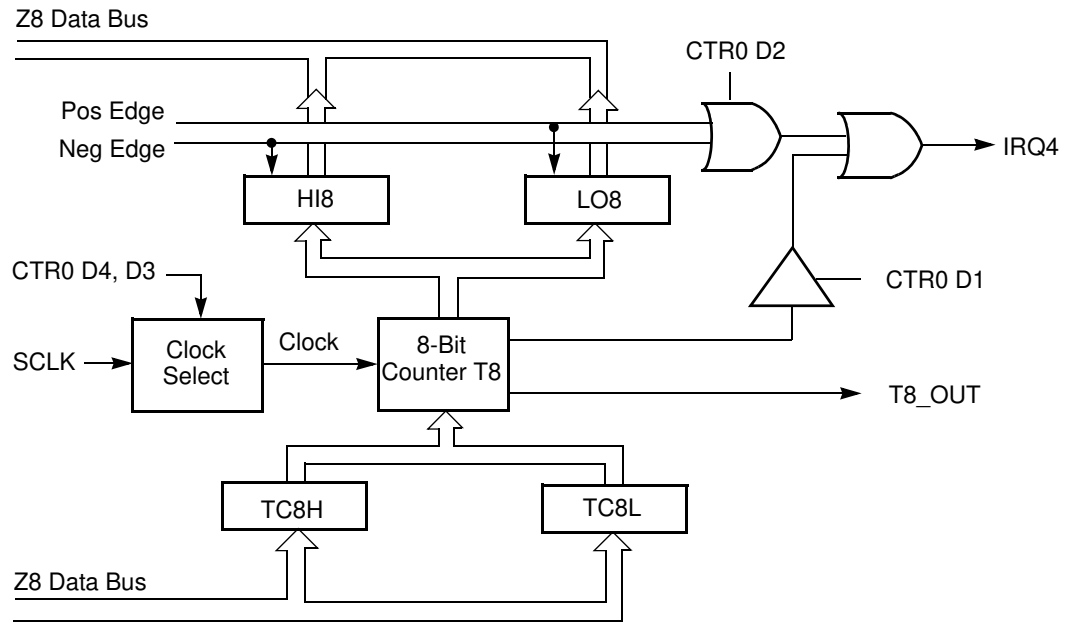

Figure 33. 8-Bit Counter/Timer Circuits



T8 Transmit Mode

Before T8 is enabled, the output of T8 depends on CTR1, D1. If it is 0, T8_OUT is 1. If it is 1, T8_OUT is 0.

When T8 is enabled, the output T8_OUT switches to the initial value (CTR1, D1). If the initial value (CTR1, D1) is 0, TC8L is loaded; otherwise, TC8H is loaded into the counter (see Figure 34). In Single-Pass Mode (CTR0, D6), T8 counts down to 0 and stops, T8_OUT toggles, and the time-out status bit (CTR0, D5) is set. A time-out interrupt can be generated if it is enabled (CTR0, D1). See Figure 35. In Modulo-N Mode, upon reaching terminal count, T8_OUT is toggled, but no interrupt is generated. Then T8 loads a new count (if the T8_OUT level now is 0), TC8L is loaded; if it is 1, TC8H is loaded. T8 counts down to 0, toggles T8_OUT, sets the time-out status bit (CTR0, D5) and generates an interrupt if enabled (CTR0, D1). One cycle is thus completed. T8 then loads from TC8H or TC8L according to the T8_OUT level, and repeats the cycle. See Figure 36.

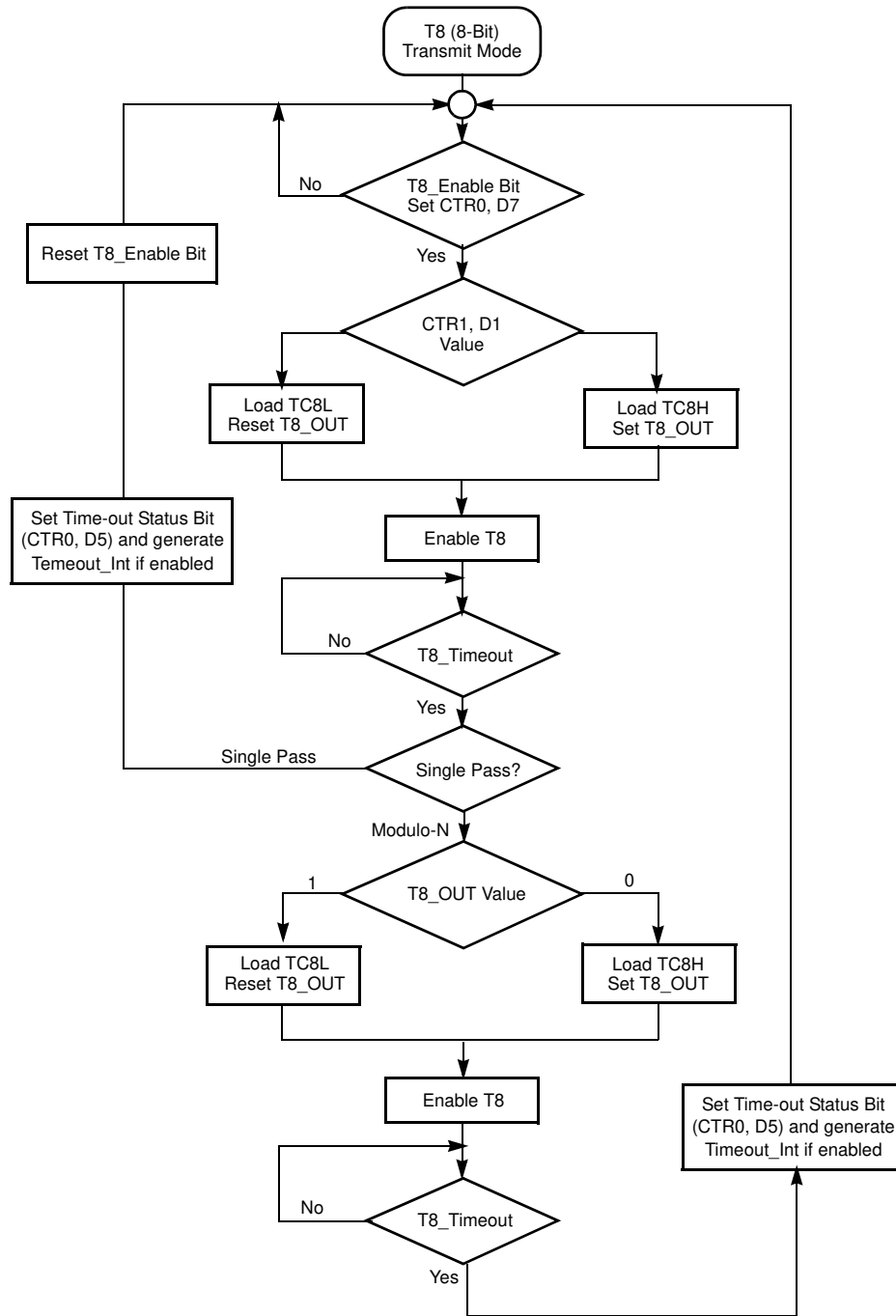

Figure 34. Transmit Mode Flowchart

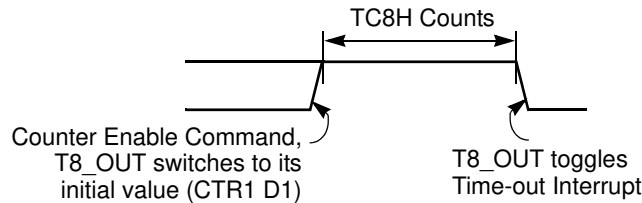

Figure 35. T8_OUT in Single-Pass Mode

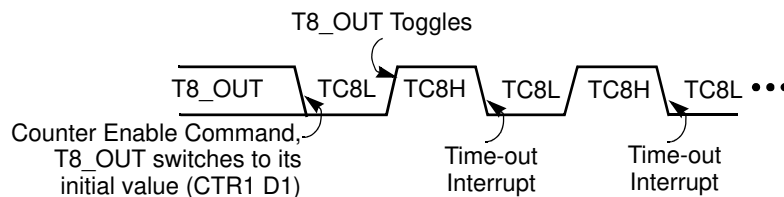



Figure 36. T8_OUT in Modulo-N Mode

You can modify the values in TC8H or TC8L at any time. The new values take effect when they are loaded. To ensure known operation, do not write these registers at the time the values are to be loaded into the counter/timer. *An initial count of 1 is not allowed (a nonfunction occurs).* An initial count of 0 causes TC8 to count from 0 to FFh to FEh.

► **Note:** “h” is used for hexadecimal values.

Transition from 0 to FFh is not a time-out condition.

 **Caution:** Do not use the same instructions for stopping the counter/timers and setting the status bits.

Two successive commands are necessary. First, the counter/timers must be stopped, and second, the status bits must be reset. These commands are required because it takes one counter/timer clock interval for the initiated event to actually occur.

T8 Demodulation Mode

You need to program TC8L and TC8H to FFh. After T8 is enabled, when the first edge (rising, falling, or both, depending on CTR1, D5, D4) is detected, it starts to count down. When a subsequent edge (rising, falling, or both, depending on CTR1, D5, D4) is detected during counting, the current value of T8 is one's complemented and put into one of the capture registers. If it is a positive edge, data is

put into LO8; if it is a negative edge, HI8. From that point, one of the edge-detect status bits (CTR1, D1, D0) is set, and an interrupt can be generated if enabled (CTR0, D2). Meanwhile, T8 is loaded with FFh and starts counting again. If T8 reaches 0, the time-out status bit (CTR0, D5) is set, an interrupt can be generated if enabled (CTR0, D1), and T8 continues counting from FFh (see Figure 37 and Figure 38).

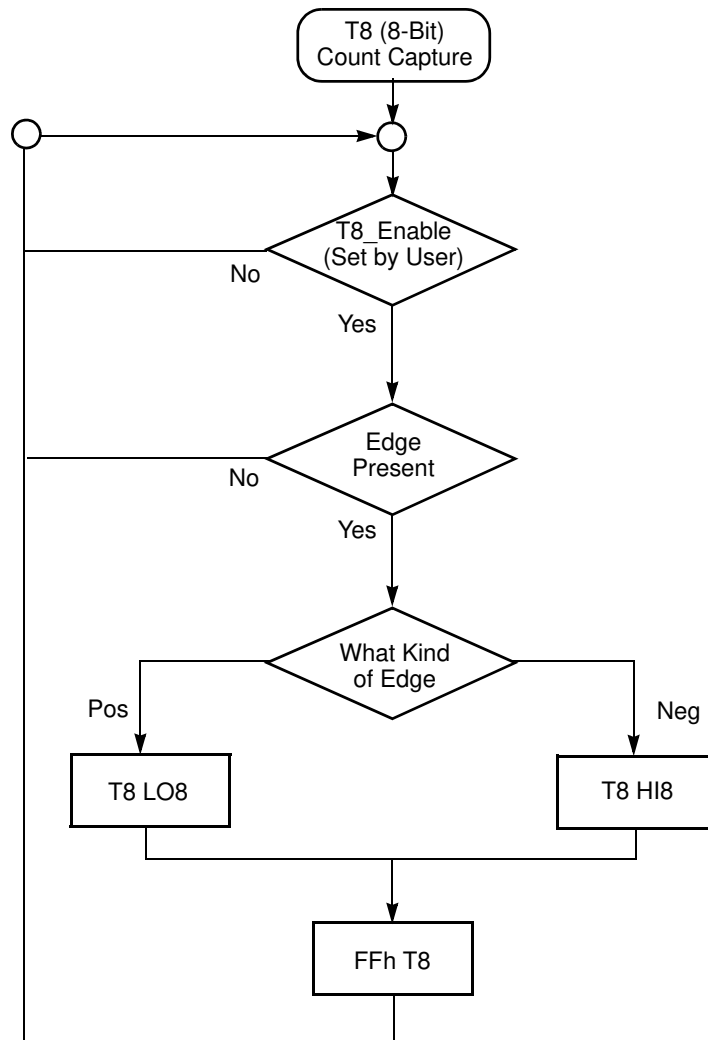

Figure 37. Demodulation Mode Count Capture Flowchart

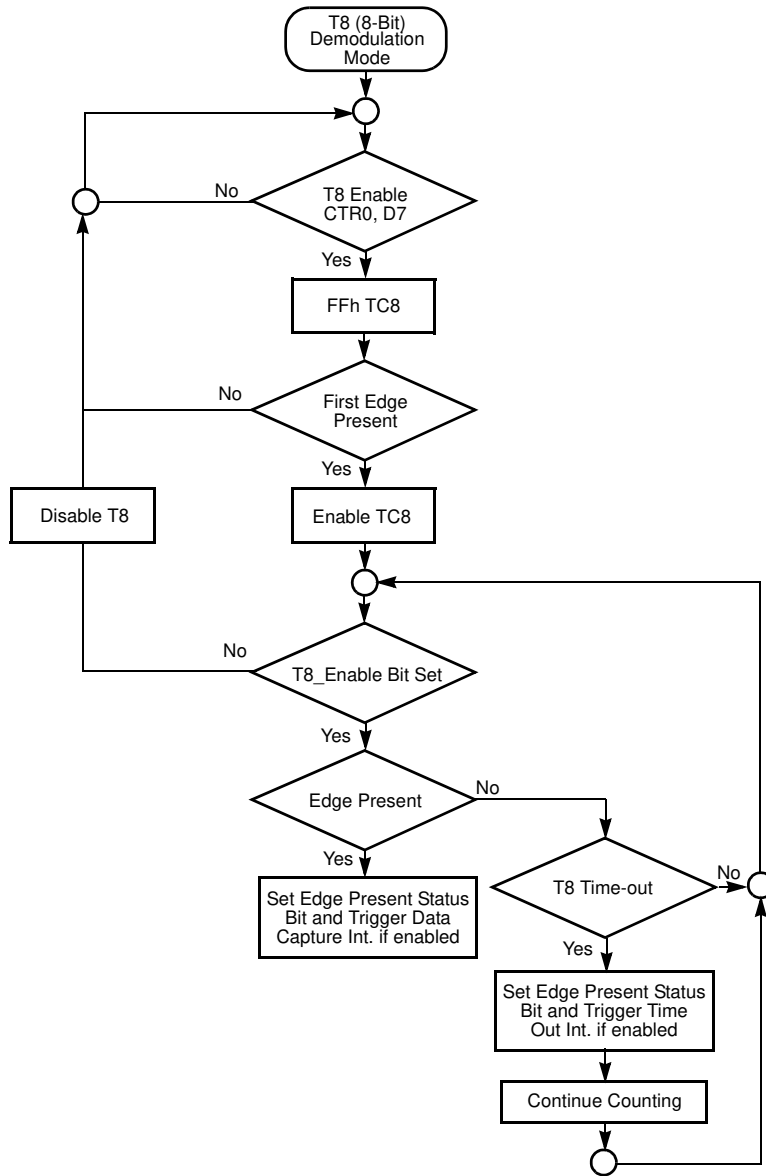

Figure 38. Demodulation Mode Flowchart

Sixteen-Bit Counter/Timer Circuits

Figure 39 shows the 16-bit counter/timer circuits.

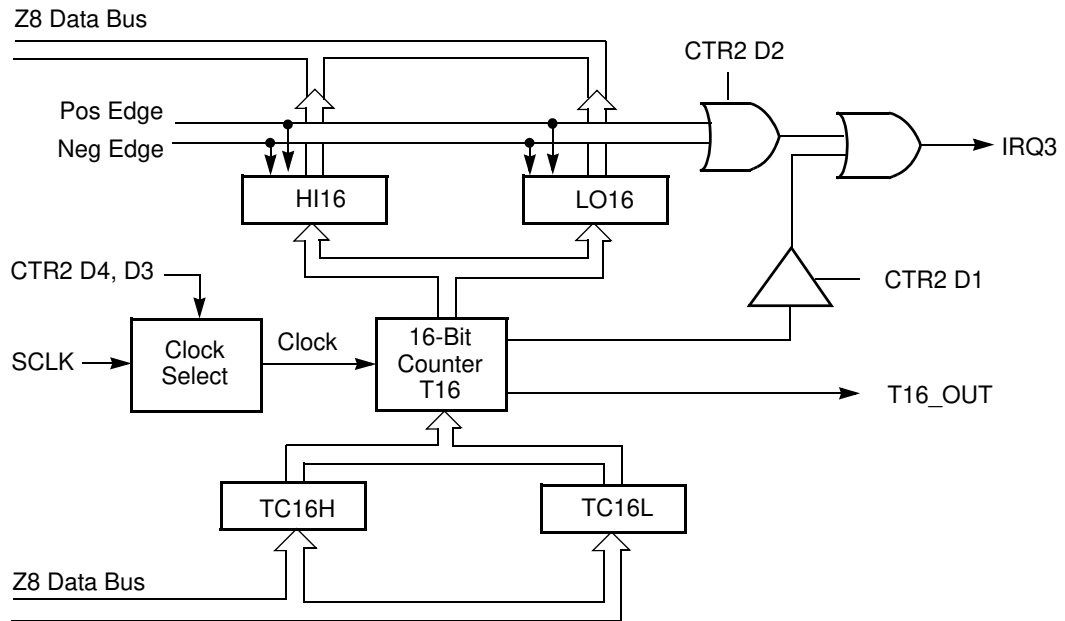

Figure 39. 16-Bit Counter/Timer Circuits

T16 Transmit Mode

In Normal or Ping-Pong Mode, the output of T16, when not enabled, is dependent on CTR1, D0. If the result is a 0, T16_OUT is a 1; if it is a 1, T16_OUT is 0. You can force the output of T16 to either a 0 or 1 whether it is enabled or not by programming CTR1 D3, D2 to a 10 or 11.

When T16 is enabled, TC16H * 256 + TC16L is loaded, and T16_OUT is switched to its initial value (CTR1, D0). When T16 counts down to 0, T16_OUT is toggled (in Normal or Ping-Pong Mode), an interrupt is generated if enabled (CTR2, D1), and a status bit (CTR2, D5) is set.

► **Note:** Global interrupts override this function as described in “Interrupts” on page 54.

If T16 is in Single-Pass Mode, T16 is stopped at this point (see Figure 40). If T16 is in Modulo-N Mode, T16 is loaded with TC16H * 256 + TC16L and the counting continues (see Figure 41).

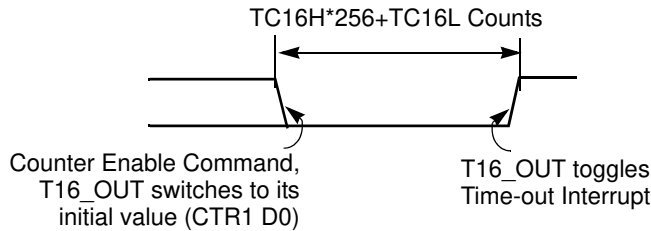

Figure 40. T16_OUT in Single-Pass Mode

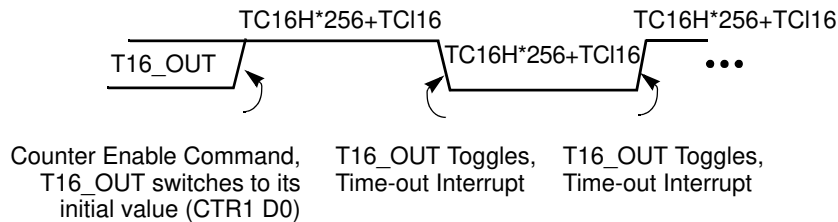

Figure 41. T16_OUT in Modulo-N Mode

You can modify the values in TC16H and TC16L at any time. The new values take effect when they are loaded. To ensure known operation, do not load these registers at the time the values are to be loaded into the counter/timer. An initial count of 1 is not allowed. An initial count of 0 causes T16 to count from 0 to FFFFh to FFFEh. Transition from 0 to FFFFh is not a time-out condition.

T16 Demodulation Mode

You need to program TC16L and TC16H to FFh. After T16 is enabled, when the first edge (rising, falling, or both, depending on CTR1 D5, D4) is detected, T16 captures HI16 and LO16, reloads, and begins counting.

If D6 of CTR2 Is 0

When a subsequent edge (rising, falling, or both, depending on CTR1, D5, D4) is detected during counting, the current count in T16 is one's complemented and put into HI16 and LO16. When data is captured, one of the edge-detect status bits (CTR1, D1, D0) is set, and an interrupt is generated if enabled (CTR2, D2). From that point, T16 is loaded with FFFFh and starts again.

This T16 mode is generally used to measure mark time, defined as the length of time between carrier signal bursts (marks).

If D6 of CTR2 Is 1

T16 ignores the subsequent edges in the input signal and continues counting down. A time-out of T8 causes T16 to capture its current value and generate an interrupt if enabled (CTR2, D2). In this case, T16 does not reload and continues counting. If the D6 bit of CTR2 is toggled (by writing a 0 and then a 1 to it), T16 captures and reloads on the next edge (rising, falling, or both, depending on CTR1, D5, D4), thereby continuing to ignore subsequent edges.

This T16 mode is generally used to measure mark time, defined by the length of time between active carrier signal bursts (marks).

When T16 reaches 0, it continues counting from FFFFh. Meanwhile, a status bit (CTR2, D5) is set, and an interrupt time-out can be generated if enabled (CTR2, D1).

Ping-Pong Mode

This operation mode (see Figure 42) is only valid in transmit mode. T8 and T16 must be programmed in Single-Pass Mode (CTR0, D6; CTR2, D6), and Ping-Pong Mode must be programmed in CTR1, D3, D2. You can begin the operation by enabling either T8 or T16 (CTR0, D7 or CTR2, D7). For example, if T8 is enabled, T8_OUT is set to this initial value (CTR1, D1). According to T8_OUT's level, TC8H or TC8L is loaded into T8. After the terminal count is reached, T8 is disabled, and T16 is enabled. T16_OUT switches to its initial value (CTR1, D0), data from TC16H and TC16L is loaded, and T16 starts to count. After T16 reaches the terminal count, it stops, T8 is enabled again, and the entire cycle repeats. Interrupts can be allowed when T8 or T16 reaches terminal control (CTR0, D1; CTR2, D1). To stop the Ping-Pong operation, write 00 to bits D3 and D2 of CTR1.

- ▶ **Note:** Enabling Ping-Pong operation while the counter/timers are running might cause intermittent counter/timer function. Disable the counter/timers and then reset the status flags before instituting this operation.

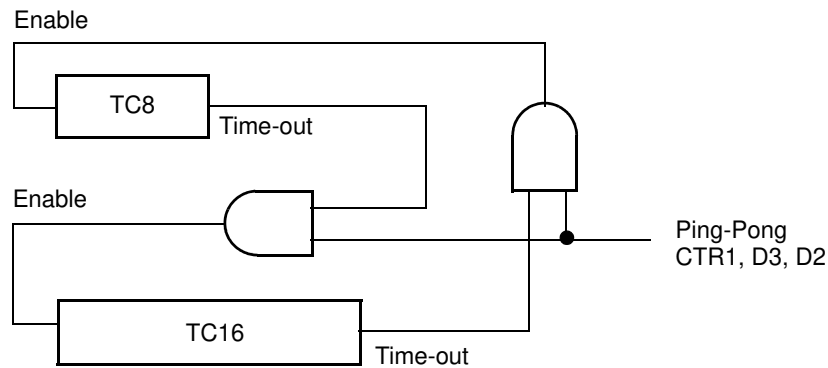

Figure 42. Ping-Pong Mode

Starting Ping-Pong Mode

First, make sure both counter/timers are not running. Then set T8 into Single-Pass Mode (CTR0, D6), set T16 into Single-Pass Mode (CTR2, D6), and set the Ping-Pong Mode (CTR1, D2, D3). These instructions do not have to be in any particular order. Finally, start Ping-Pong Mode by enabling either T8 (CTR0, D7) or T16 (CTR2, D7).

During Ping-Pong Mode

The enable bits of T8 and T16 (CTR0, D7; CTR2, D7) are set and cleared alternately by hardware. The time-out bits (CTR0, D5; CTR2, D5) are set every time the counter/timers reach the terminal count.

Output Circuit

Figure 43 shows the output circuit.

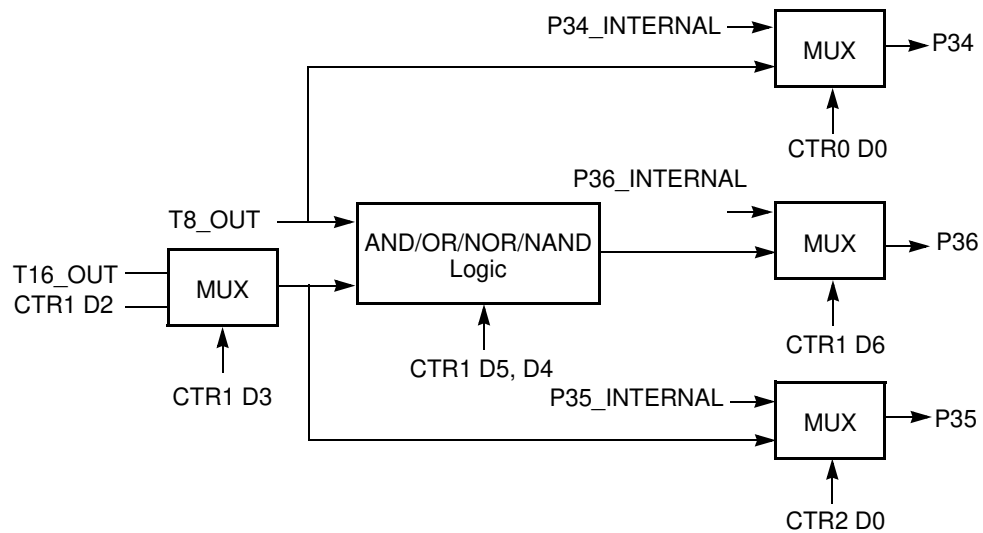

Figure 43. Output Circuit

Interrupts

The Z86D86 features six different interrupts. The interrupts are maskable and prioritized, as shown in Figure 44. The six sources are divided as follows: three sources are claimed by Port 3 lines P33–P31, two by the counter/timers, and one by LBD (see Table 21). The Interrupt Mask Register, globally or individually, enables or disables the six interrupt requests.

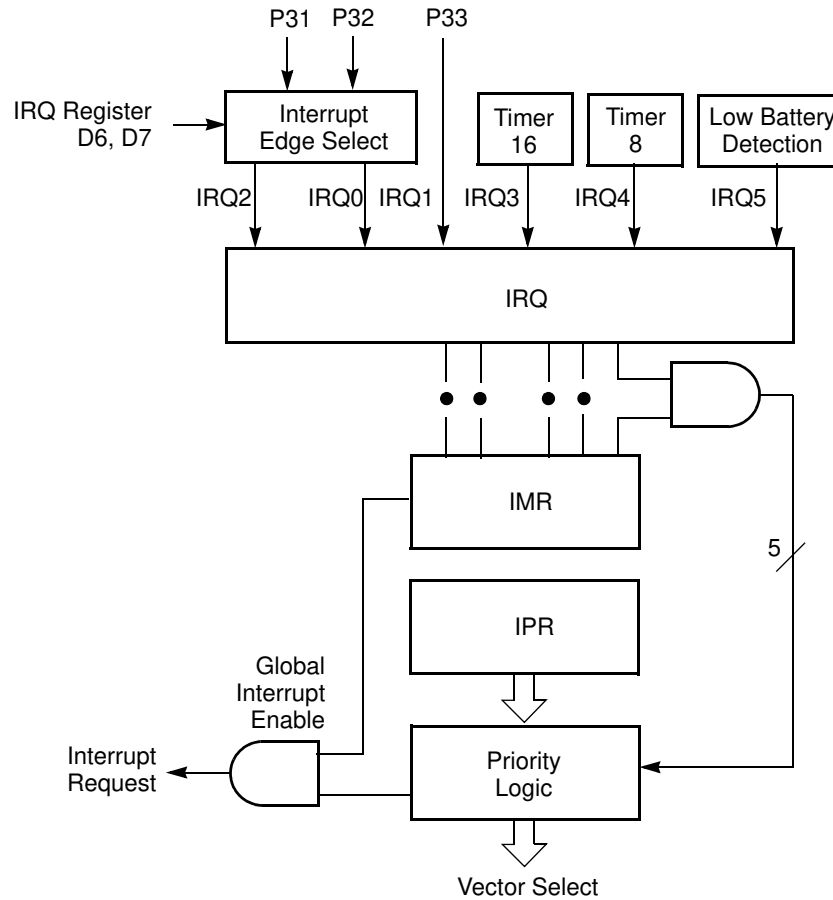

Figure 44. Interrupt Block Diagram

Table 21. Interrupt Types, Sources, and Vectors

Name	Source	Vector Location	Comments
IRQ0	P32	0,1	External (P32), Rising Falling Edge Triggered
IRQ1	P33	2,3	External (P33), Falling Edge Triggered
IRQ2	P31, T _{IN}	4,5	External (P31), Rising Falling Edge Triggered
IRQ3	T16	6,7	Internal
IRQ4	T8	8,9	Internal
IRQ5	LBD	10,11	Internal



When more than one interrupt is pending, priorities are resolved by a programmable priority encoder controlled by the Interrupt Priority Register. An interrupt machine cycle is activated when an interrupt request is granted. As a result, all subsequent interrupt are disabled, and the Program Counter and Status Flags are saved. The cycle then branches to the program memory vector location reserved for that interrupt. All Z86D86 interrupts are vectored through locations in the program memory. This memory location and the next byte contain the 16-bit address of the interrupt service routine for that particular interrupt request. To accommodate polled interrupt systems, interrupt inputs are masked, and the Interrupt Request register is polled to determine which of the interrupt requests require service.

An interrupt resulting from AN1 is mapped into IRQ2, and an interrupt from AN2 is mapped into IRQ0. Interrupts IRQ2 and IRQ0 can be rising, falling, or both edge triggered; all are programmable by the user. The software can poll to identify the state of the pin.

Programming bits for the Interrupt Edge Select are located in the IRQ Register (R250), bits D7 and D6. The configuration is indicated in Table 22.

Table 22. IRQ Register*

IRQ		Interrupt Edge	
D7	D6	IRQ2 (P31)	IRQ0 (P32)
0	0	F	F
0	1	F	R
1	0	R	F
1	1	R/F	R/F

Notes:

F = Falling Edge

R = Rising Edge

*In stop mode, the comparators are turned off.

Clock

The Z86D86 on-chip oscillator has a high-gain, parallel-resonant amplifier for connection to a crystal, LC, ceramic resonator, or any suitable external clock source (XTAL1 = Input, XTAL2 = Output). The crystal must be AT cut, 1 MHz to 8 MHz maximum, with a series resistance (RS) less than or equal to 100 Ohms. The Z86D86 on-chip oscillator can be driven with a low-cost RC network or other suitable external clock source.

For 32-kHz crystal operation, an external feedback resistor (R_f) and a serial resistor (R_d) are required. See Figure 45.

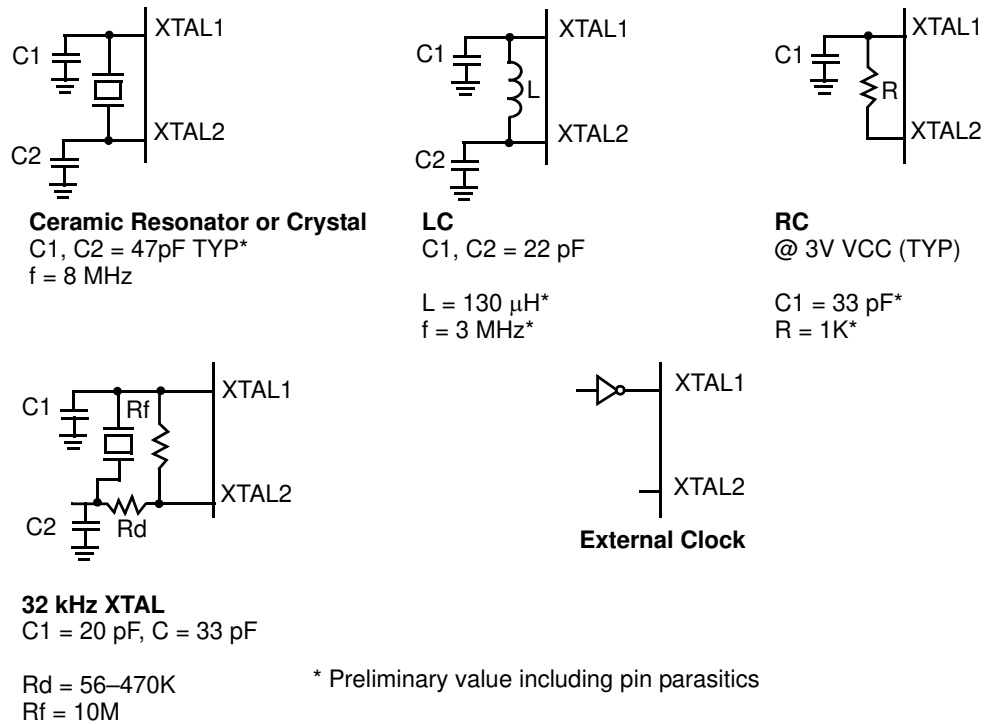

Figure 45. Oscillator Configuration

The crystal needs to be connected across XTAL1 and XTAL2 using the recommended capacitors (capacitance greater than or equal to 22 pF) from each pin to ground. The RC oscillator configuration is an external resistor connected from XTAL1 to XTAL2, with a frequency-setting capacitor from XTAL1 to ground (see Figure 45).

Power-On Reset (POR)

A timer circuit clocked by a dedicated on-board RC oscillator is used for the Power-On Reset (POR) timer function. The POR time allows V_{CC} and the oscillator circuit to stabilize before instruction execution begins.

The POR timer circuit is a one-shot timer triggered by one of three conditions:

- Power Fail to Power OK status including waking up from V_{LV} Standby
- Stop-Mode Recovery (if D5 of SMR = 1)
- WDT Time-Out



The POR time is a nominal 5 ms. Bit 5 of the Stop-Mode Register determines whether the POR timer is bypassed after Stop-Mode Recovery (typical for external clock, RC, and LC oscillators).

HALT

HALT turns off the internal CPU clock, but not the XTAL oscillation. The counter/timers and external interrupts IRQ0, IRQ1, IRQ2, IRQ3, and IRQ4 remain active. The devices are recovered by interrupts, either externally or internally generated. An interrupt request must be executed (enabled) to exit HALT Mode. After the interrupt service routine, the program continues from the instruction after the HALT.

STOP

This instruction turns off the internal clock and external crystal oscillation and reduces the standby current to 10 μ A or less. STOP Mode is terminated only by a reset (such as WDT time-out), POR, SMR, or external reset. This termination causes the processor to restart the application program at address 000CH. To enter STOP (or HALT) mode, you need to first flush the instruction pipeline to avoid suspending execution in mid-instruction. To execute this action, you must execute a NOP (op code = FFH) immediately before the appropriate sleep instruction. For example:

```

FF      NOP      ; clear the pipeline
6F      STOP     ; enter STOP Mode

```

or

```

FF      NOP      ; clear the pipeline
7F      HALT     ; enter HALT Mode

```

Port Configuration Register (PCON)

The PCON register configures the comparator output on Port 3. It is located in the expanded register 2 at Bank F, location 00, as shown in Figure 46.

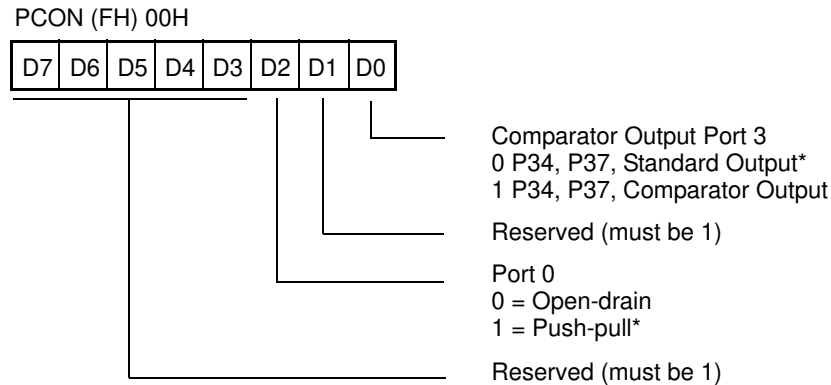

*Default setting after reset

Figure 46. Port Configuration Register (PCON)—Write Only

Comparator Output Port 3 (D0)

Bit 0 controls the comparator used in Port 3. A 1 in this location brings the comparator outputs to P34 and P37, and a 0 releases the port to its standard (/O configuration).

Port 0 Output Mode (D2)

Bit 2 controls the output mode of Port 0. A 1 in this location sets the output to push-pull, and a 0 sets the output to open-drain.

Stop-Mode Recovery Register (SMR)

This register selects the clock divide value and determines the mode of Stop-Mode Recovery (Figure 47). All bits are write only except bit 7, which is read only. Bit 7 is a flag bit that is hardware set on the condition of STOP recovery and reset by a power-on cycle. Bit 6 controls whether a low level or a high level at the XOR-gate input is required from the recovery source. Bit 5 controls the reset delay after recovery. Bits D2, D3, and D4, or the SMR register, specify the source of the Stop-Mode Recovery signal. Bit D0 determines if SCLK/TCLK (shown in Figure 48) are divided by 16 or not. The SMR is located in Bank F of the Expanded Register Group at address 0BH.

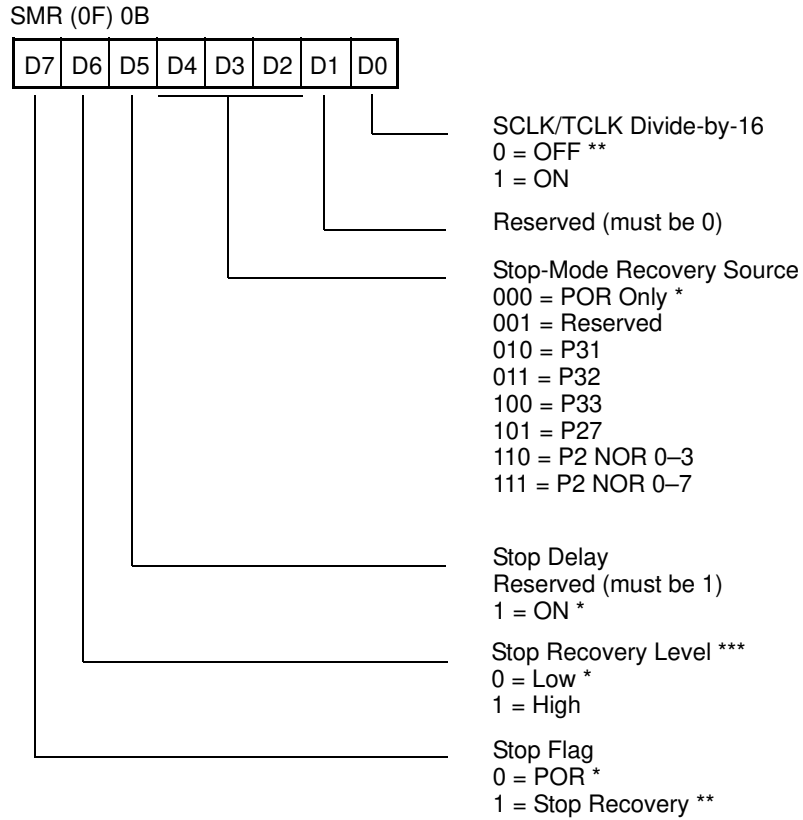

* Default setting after reset

** Default setting after reset and Stop-Mode Recovery

*** At the XOR gate input

Figure 47. Stop-Mode Recovery Register

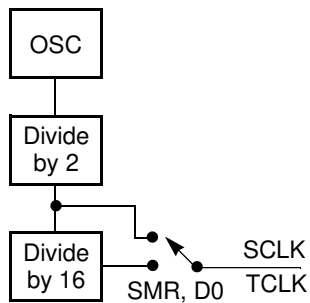

Figure 48. SCLK Circuit



SCLK/TCLK Divide-by-16 Select (D0)

D0 of the SMR controls a Divide-by-16 prescaler of SCLK/TCLK. The purpose of this control is to selectively reduce device power consumption during normal processor execution (SCLK control) and/or HALT Mode (where TCLK sources interrupt logic). After Stop-Mode Recovery, this bit is set to a 0.

Stop-Mode Recovery Source (D2, D3, and D4)

These three bits of the SMR specify the wake-up source of the STOP recovery (Figure 49 and Table 23 on page 63).

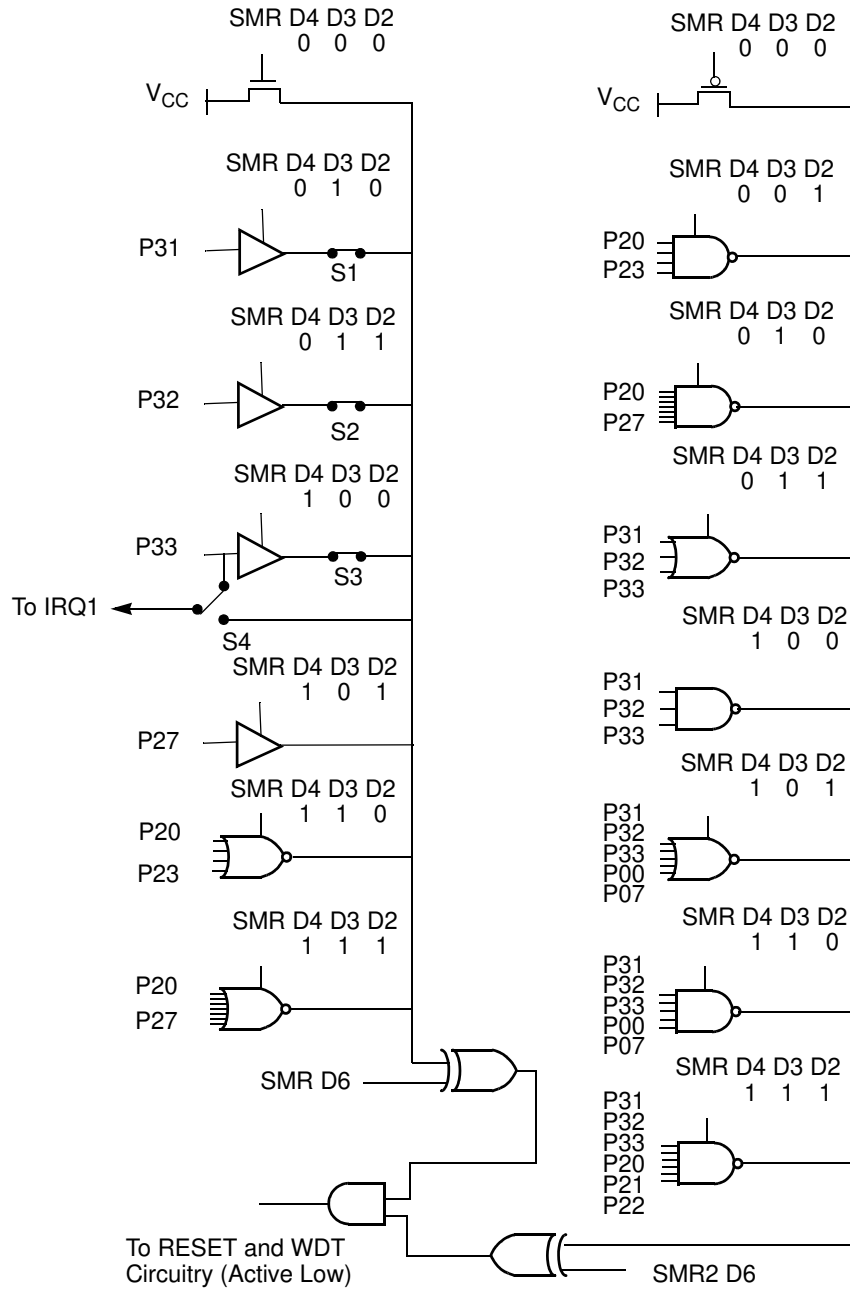

Figure 49. Stop-Mode Recovery Source



Table 23. Stop-Mode Recovery Source

SMR:432			Operation
D4	D3	D2	Description of Action
0	0	0	POR and/or external reset recovery
0	0	1	Reserved
0	1	0	P31 transition
0	1	1	P32 transition
1	0	0	P33 transition
1	0	1	P27 transition
1	1	0	Logical NOR of P20 through P23
1	1	1	Logical NOR of P20 through P27

► **Note:** Any Port 2 bit defined as an output drives the corresponding input to the default state to allow the remaining inputs to control the AND/OR function. Refer to “Stop-Mode Recovery Register 2 (SMR2)” on page 64 for other recover sources.

Stop-Mode Recovery Delay Select (D5)

This bit, if low, disables the 5-ms $\overline{\text{RESET}}$ delay after Stop-Mode Recovery. The default configuration of this bit is one. If the “fast” wake up is selected, the Stop-Mode Recovery source must be kept active for at least 5T_{pC}.

Stop-Mode Recovery Edge Select (D6)

A 1 in this bit position indicates that a High level on any one of the recovery sources wakes the Z86D86 from STOP Mode. A 0 indicates Low level recovery. The default is 0 on POR.

Cold or Warm Start (D7)

This bit is read only. It is set to 1 when the device is recovered from stop mode. The bit is set to 0 when the device reset is other than Stop-Mode Recovery (SMR).

Stop-Mode Recovery Register 2 (SMR2)

This register determines the mode of Stop-Mode Recovery for SMR2 (see Figure 50).

SMR2 (0F) DH

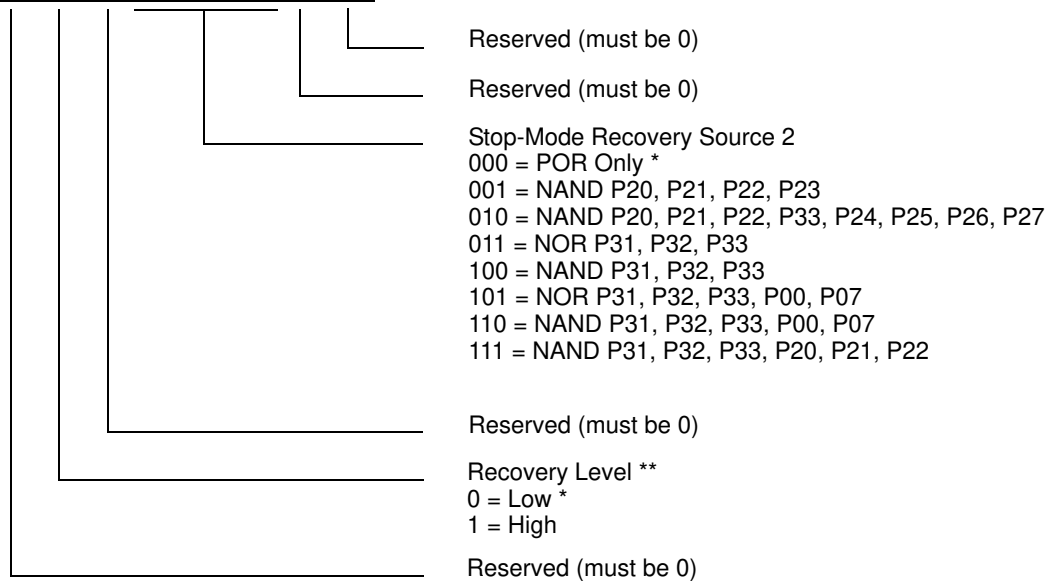
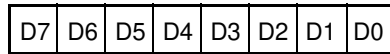

* Default setting after reset

** At the XOR gate input

Note: If used in conjunction with SMR, either of the two specified events causes a Stop-Mode Recovery.

Figure 50. Stop-Mode Recovery Register 2—(0F) DH:D2–D4, D6 Write Only

If SMR2 is used in conjunction with SMR, either of the specified events causes a Stop-Mode Recovery.

► **Note:** Port pins configured as outputs are ignored as a SMR or SMR2 recovery source. For example, if the NAND or P23–P20 is selected as the recovery source and P20 is configured as an output, the remaining SMR pins (P23–P21) form the NAND equation.

Table 24 describes the contents of the Stop-Mode Recovery register 2.



Table 24. SMR2(F)0Dh: Stop-Mode Recovery Register 2

Field	Bit Position		Value	Description
Reserved	7-----		0	Reserved (Must be 0)
Recovery Level	-6-----	W	0*	Low
			1	High
Reserved	--5-----		0	Reserved (Must be 0)
Source	---432--	W	000*	A. POR Only
			001	B. NAND of P23–P20
			010	C. NAND or P27–P20
			011	D. NOR of P33–P31
			100	E. NAND of P33–P31
			101	F. NOR of P33–P31, P00, P07
			110	G. NAND of P33–P31, P00, P07
			111	H. NAND of P33–P31, P22–P20
Reserved	-----10		00	Reserved (Must be 0)

Notes:

*Indicates the value upon Power-On Reset

Port pins configured as outputs are ignored as a SMR recovery source.

Watch-Dog Timer Mode Register (WDTMR)

The WDT is a retriggerable, one-shot timer that resets the Z8 if it reaches its terminal count. The WDT must initially be enabled by executing the WDT instruction. On subsequent executions of the WDT instruction, the WDT circuit is refreshed. The WDT circuit is driven by an on-board RC oscillator or external oscillator from the XTAL1 pin. The WDT instruction affects the Zero (Z), Sign (S), and Overflow (V) flags.

The POR clock source is selected with bit 4 of the WDT register. Bits 0 and 1 control a tap circuit that determines the minimum time-out period. Bit 2 determines whether the WDT is active during HALT, and Bit 3 determines WDT activity during STOP. Bits 5 through 7 are reserved (Figure 51). This register is accessible only during the first 60 processor cycles (122 XTAL clocks) from the execution of the first instruction after Power-On-Reset, Watch-Dog Reset, or a Stop-Mode Recovery (Figure 51). After this point, the register cannot be modified by any means, intentional or otherwise. The WDTMR cannot be read. The register is located in Bank F of the Expanded Register Group at address location 0FH. The WDTMR is organized as shown in Figure 51.

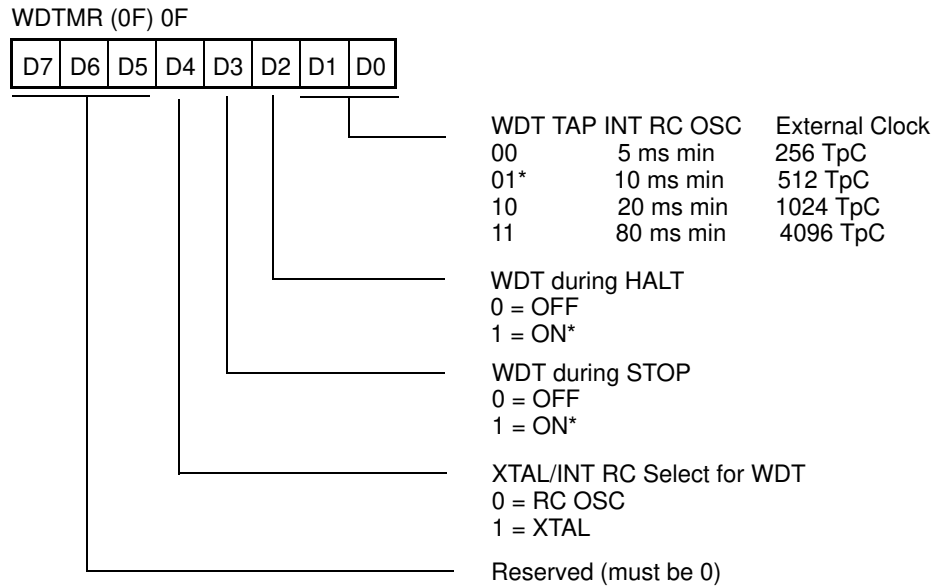

* Default setting after reset

Figure 51. Watch-Dog Timer Mode Register—Write Only

WDT Time Select (D0, D1)

This bit selects the WDT time period. It is configured as indicated in Table 25.

Table 25. WDT Time Select*

D1	D0	Time-Out of Internal RC OSC	Time-Out of XTAL Clock
0	0	5 ms min	256 TpC
0	1	10 ms min	512 TpC
1	0	20 ms min	1024 TpC
1	1	80 ms min	4096 TpC

Notes:

*TpC = XTAL clock cycle. The default on reset is 10 ms.

WDTMR During HALT (D2)

This bit determines whether or not the WDT is active during HALT Mode. A 1 indicates active during HALT. The default is 1.

WDTMR During STOP (D3)

This bit determines whether or not the WDT is active during STOP Mode. Since the XTAL clock is stopped during STOP Mode, the on-board RC has to be selected as the clock source to the WDT/POR counter. A 1 indicates active during STOP. The default is 1.

Clock Source for WDT (D4)

This bit determines which oscillator source is used to clock the internal POR and WDT counter chain. If the bit is a 1, the internal RC oscillator is bypassed, and the POR and WDT clock source is driven from the external pin, XTAL1. The default configuration of this bit is 0, which selects the RC oscillator. See Figure 51.

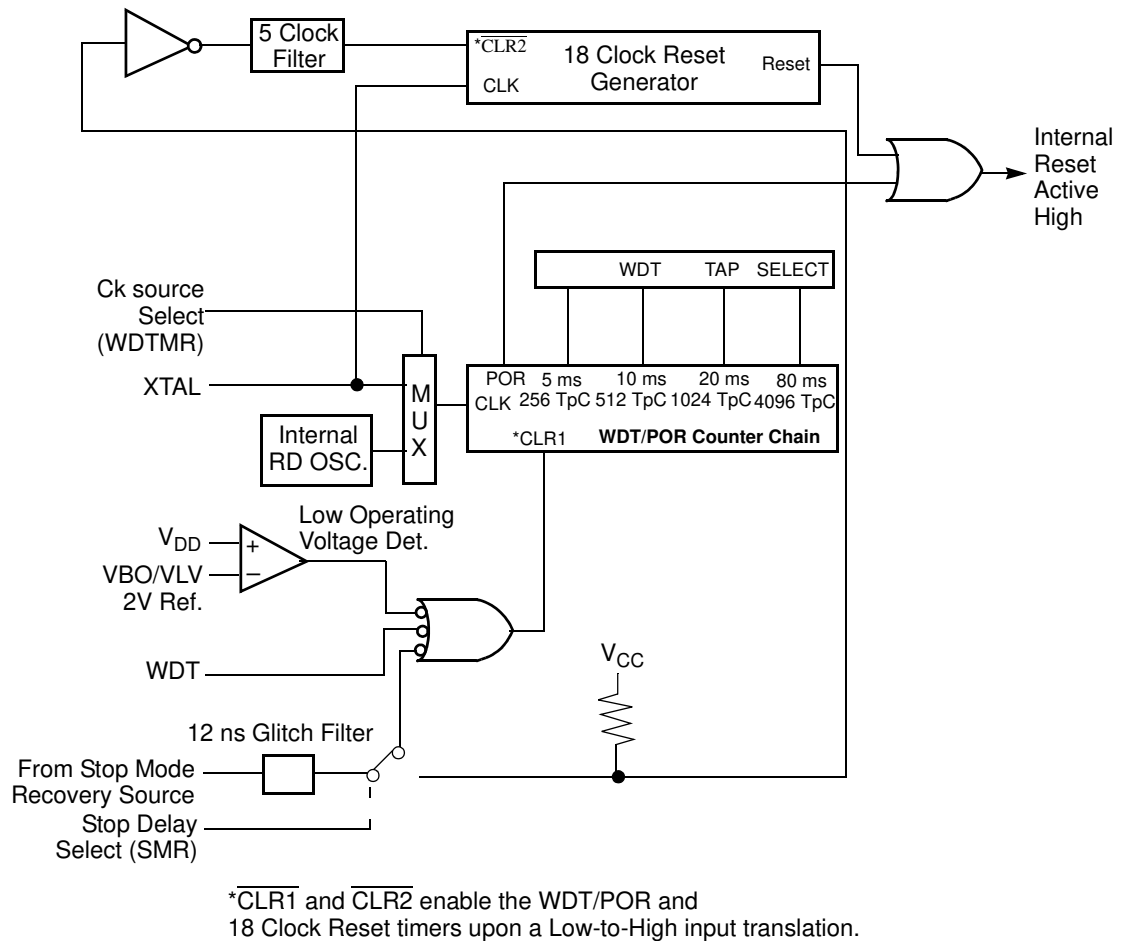

Figure 51. Resets and WDT

Mask Selectable Options

There are six Mask Selectable Options to choose from based on ROM code requirements. These are listed in Table 26.

Table 26. Mask Selectable Options

RC/Other	RC/XTAL
32 kHz XTAL	On/Off
Port 04–07 Pull-Ups	On/Off
Port 00–03 Pull-Ups	On/Off
Port 20–27 Pull-Ups	On/Off
Port 0:0–3 Mouse Mode 0.4 V_{CC} Trip	On/Off

Low Voltage/Standby

An on-chip Voltage Comparator checks that the V_{CC} is at the required level for correct operation of the device. Reset is globally driven when V_{CC} falls below V_{LV} . A further small drop in V_{CC} causes the XTAL1 and XTAL2 circuitry to stop the crystal or resonator clock. Typical low-voltage power consumption in this Low Voltage Standby mode (I_{LV}) is about 100 μ A. If the V_{CC} is allowed to stay above V_{ram} , the RAM content is preserved. When the power level is returned to above V_{LV} , the device performs a POR and functions normally.

Low Battery Detection and Flag

A Low Battery Detection circuit can be used to signal dropping voltage levels. Expanded Register Bank 0Dh register 0Ch bit 0 and 1 are used for this option.

Bit D0 is used to enable/disable this function.

Bit D1 is the status flag bit of this LBD.

The minimum operating voltage varies with the temperature and operating frequency, while V_{LV} varies with temperature only.

Ordering Information

Figure 52 shows the 28-pin SOIC package diagram. Figure 53 shows the 28-pin DIP package diagram.

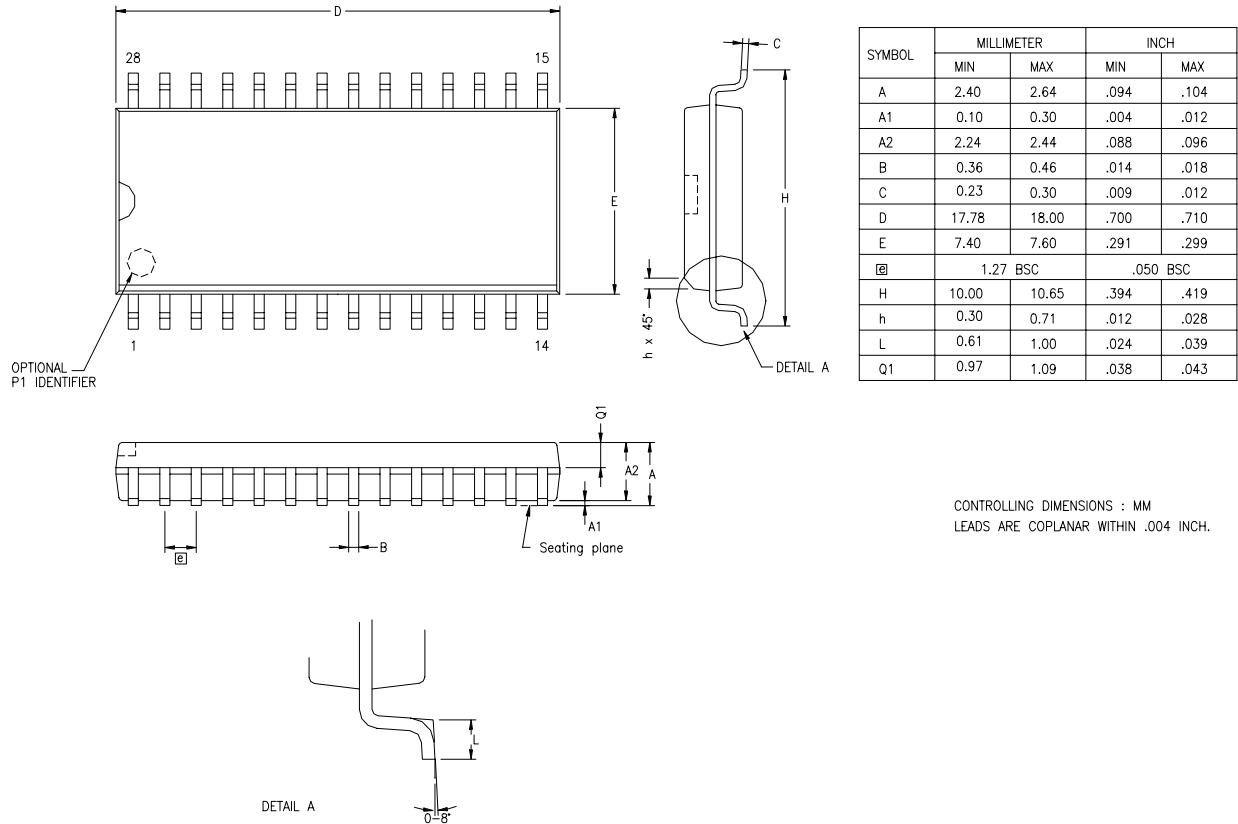
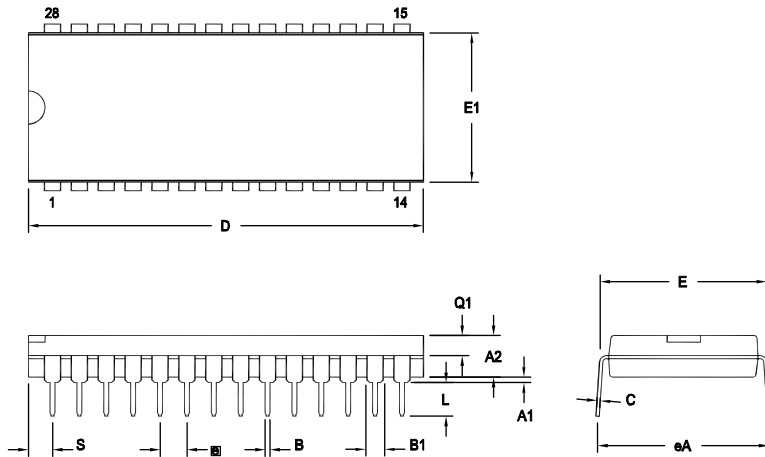

Figure 52. 28-Pin SOIC Package Diagram



SYMBOL	OPT #	MILLIMETER		INCH	
		MIN	MAX	MIN	MAX
A1		0.38	1.02	.015	.040
A2		3.18	4.19	.125	.165
B		0.38	0.53	.015	.021
B1	01	1.40	1.65	.055	.065
	02	1.14	1.40	.045	.055
C		0.23	0.38	.009	.015
D	01	36.58	37.34	1.440	1.470
	02	35.31	35.94	1.390	1.415
E		15.24	15.75	.600	.620
E1	01	13.59	14.10	.535	.555
	02	12.83	13.08	.505	.515
e		2.54 TYP		.100 BSC	
eA		15.49	16.76	.610	.660
L		3.05	3.81	.120	.150
Q1	01	1.40	1.91	.055	.075
	02	1.40	1.78	.055	.070
S	01	1.52	2.29	.060	.090
	02	1.02	1.52	.040	.060

CONTROLLING DIMENSIONS : INCH

OPTION TABLE	
OPTION #	PACKAGE
01	STANDARD
02	IDF

Note: ZiLOG supplies both options for production. Component layout PCB design should cover bigger option 01.

Figure 53. 28-Pin DIP Package Diagram

Z86D86 8.0 MHz

28-Pin DIP Z86D8608PSC

28-Pin SOIC Z86D8608SSC

For fast results, contact your local ZiLOG sales office for assistance in ordering the part desired.

Codes

Figure 54 shows an example of what the ordering codes represent.

Example:

Z 86D86 08 P S C is a Z86D86, 8 MHz, DIP, 0 °C to 70 °C, Plastic Standard Flow

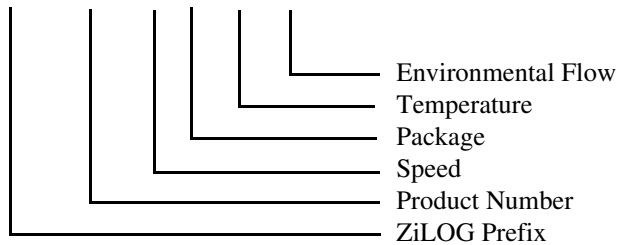

Figure 54. Ordering Codes Example

Package

P = Plastic DIP

S = SOIC

Temperature

S = 0 °C to +70 °C

Speed

8 = 8.0 MHz

Environmental

C = Plastic Standard

Precharacterization Product

The product represented by this document is newly introduced and ZiLOG has not completed the full characterization of the product. The document states what ZiLOG knows about this product at this time, but additional features or nonconformance with some aspects of the document may be found, either by ZiLOG or its customers in the course of further application and characterization work. In addition, ZiLOG cautions that delivery may be uncertain at times, due to startup yield issues.



Customer Feedback Form

Z86D86 28-Pin Low-Voltage OTP Microcontroller

If you experience any problems while operating this product, or if you note any inaccuracies while reading this product specification, please copy and complete this form, then mail or fax it to ZiLOG (see *Return Information*, below). We also welcome your suggestions!

Customer Information

Name	Country
Company	Phone
Address	Fax
City/State/Zip	email

Product Information

Serial # or Board Fab #/Rev #
Software Version
Document Number
Host Computer Description/Type

Return Information

ZiLOG
System Test/Customer Support
532 Race Street
San Jose, CA 95126-3432
Fax: (408) 558-8300

Problem Description or Suggestion

Provide a complete description of the problem or your suggestion. If you are reporting a specific problem, include all steps leading up to the occurrence of the problem. Attach additional pages as necessary.
