

OS04A10 4-megapixel product brief



4 Megapixel Nyxel® NIR and Ultra Low Light Image Sensor



available in
a lead-free
package

OmniVision's OS04A10 is a 2.9 μm pixel size, 4 megapixel (MP) resolution member of its industry-leading Nyxel® near-infrared (NIR) and ultra-low light (ULL) image sensor family. It provides security cameras with greater zoom range and AI-enabled surveillance systems with better object identification and facial authentication accuracy. Additionally, it maintains the industry's best performance, day and night, for detecting incident light in both the visible and NIR wavelengths to produce even more precise color and monochrome images. The OS04A10 also features OmniVision's PureCel®-S die stacking technology, which enables its extremely small package and large 2.9 micron pixel size.

OmniVision's Nyxel® NIR technology imparts the OS04A10 with exceptional quantum efficiency (QE) of 60% at 850 nm and 40% at 940 nm, which is 3x to 5x better than sensors without this technology. This excellent QE enables the use

of lower power IR illumination in total darkness, resulting in an estimated 3x reduction in system-level power consumption. Additionally, 940 nm NIR lighting cannot be detected by human eyes in dark indoor settings, while the 850 nm light is ideal for outdoor security cameras.

The OS04A10 achieves industry leading $\text{SNR}_{1850\text{nm}}$ and $\text{SNR}_{1940\text{nm}}$ performance that is 2x to 3x smaller when compared with the leading known available competitor sensors. Additionally, OmniVision's integrated dual-conversion-gain technology provides the industry's best ULL and high dynamic range (HDR) performance, along with greater flexibility in selecting a companion image signal processor.

Find out more at www.ovt.com.



OmniVision.

Applications

- Security Cameras
- High Resolution Consumer Cameras
- Action Cameras

Product Features

- QE enhancement in NIR range
- support for image size:
 - 2688 x 1520
 - VGA
 - QVGA, and any cropped size
- high dynamic range
- high sensitivity
- image sensor processor functions:
 - defective pixel cancelation
 - DCG combination
 - automatic black level correction
 - PWL compression, etc.
- pixel data: 12b RAW RGB
- SCCB for register programming
- programmable GPIOs
- high speed serial data transfer with MIPI CSI-2 or LVDS
- external frame synchronization capability
- embedded temperature sensor
- one-time programmable (OTP) memory

OS04A10



Ordering Information

- OS04A10-J72A-1B (color, lead-free)
72-pin fan-out package

Product Specifications

- active array size: 2688 x 1520
- maximum image transfer rate: 30x3 fps @ 1520p
- power supply:
 - analog: 2.8V
 - digital: 1.2V
 - I/O pads: 1.8V
- power requirements:
 - active: 300 mW
- temperature range:
 - operating: -30°C to +85°C junction temperature
- output interfaces: up to 4-lane MIPI CSI-2 or LVDS
- lens size: 1/1.79"
- lens chief ray angle: 9°
- scan mode: progressive
- shutter: rolling shutter
- output formats: single exposure HDR - 16-bit combined RAW, 12-bit (PWL) compressed combined RAW; dual exposure HDR - 16-bit combined RAW + 12-bit VS RAW, 12-bit (PWL) compressed combined RAW + 12-bit VS RAW; 3-exposure HDR - 12-bit long exposure + 12-bit medium exposure + 12-bit short exposure
- pixel size: 2.9 μm x 2.9 μm
- image area: 7841.6 μm x 4454.4 μm

Functional Block Diagram

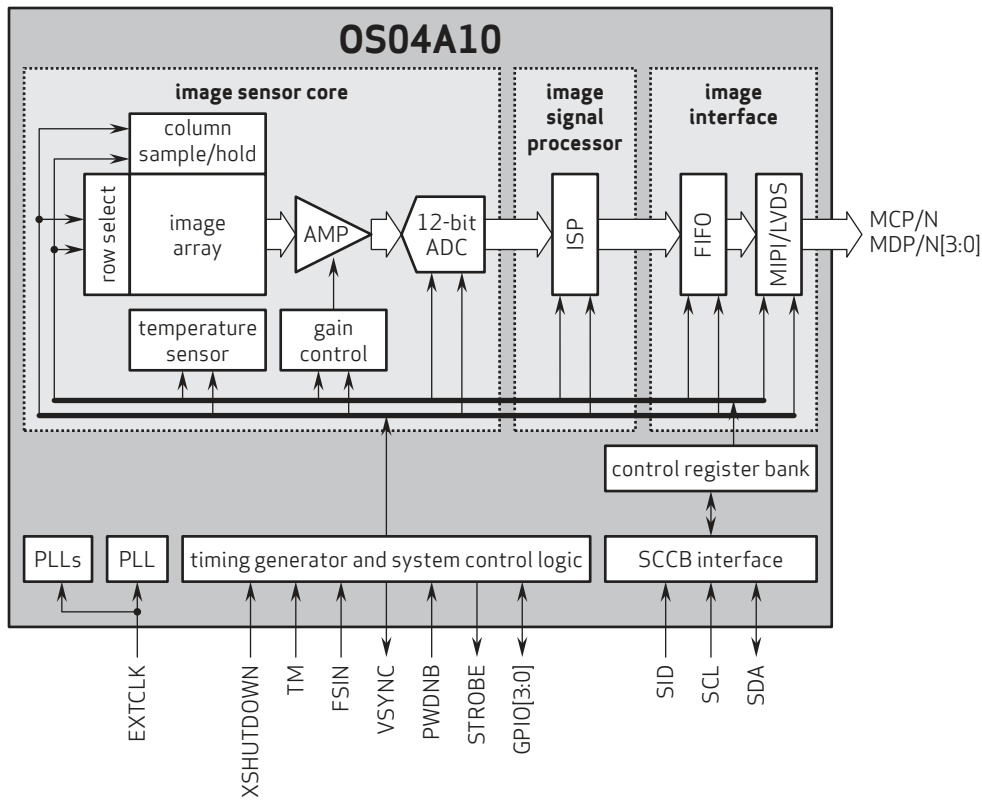

4275 Burton Drive
Santa Clara, CA 95054
USA

Tel: + 1 408 567 3000
Fax: + 1 408 567 3001
www.ovt.com

OmniVision reserves the right to make changes to their products or to discontinue any product or service without further notice. OmniVision, the OmniVision logo, PureCel, and Nyxel are registered trademarks of OmniVision Technologies, Inc. All other trademarks are the property of their respective owners.



OmniVision