

RECOMMENDED P.C.B. LAYOUT

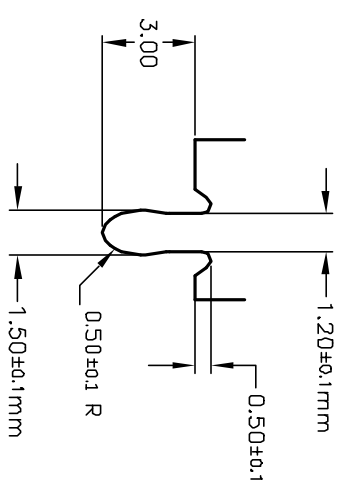

BRACKET LEG

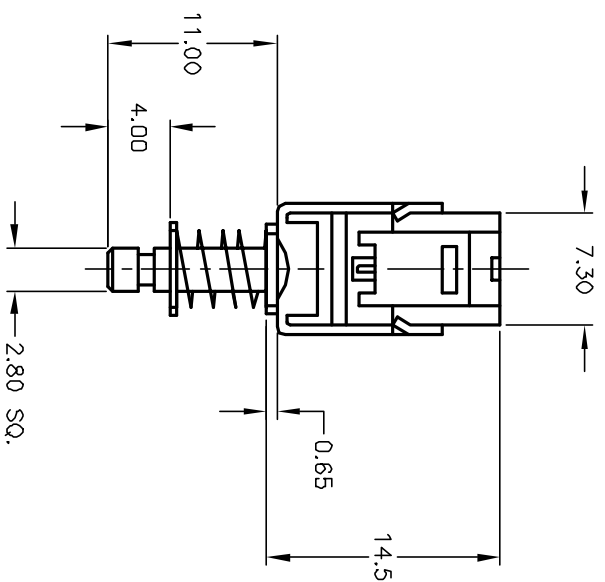
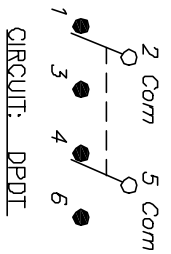

CIRCUIT: DPDT

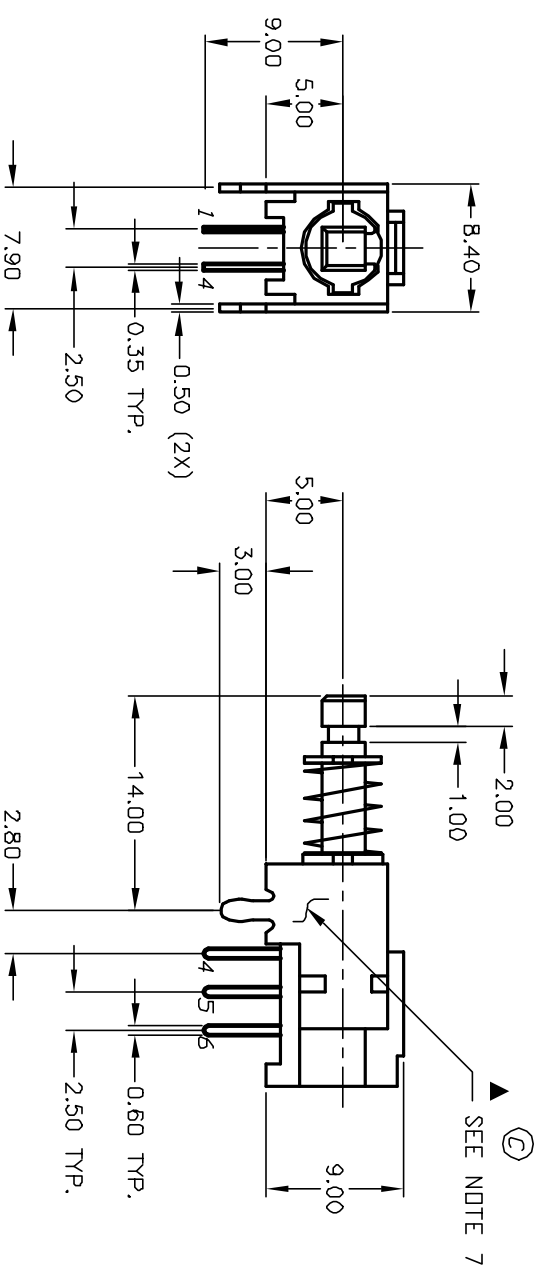

- NOTES:
1. ALL DIMENSIONS IN MM
 2. GENERAL TOLERANCE: X.X=±0.4
X.XX=±0.25
 3. TERM. NOS. FOR REFERENCE ONLY.
 4. RATINGS: 0.1A@30VDC
 5. CONTACT RESISTANCE: 0.1 Ohms max.
 6. TRAVEL: 2.00mm
 7. BRACKET TO BE PLATED 120 micro Inch min.
TIN PLATE TO MIL STD 202F-208F SOLDERABILITY TEST.

REV.	ECN No.	DESCRIPTION	DATE	CHKD
C	11729	REVISED AND REDRAWN	10/10/01	CJB

TITLE	SCALE	DATE	DR	DWG	REV
MTH2UEE W/KZX BRACKET	2:1	10/10/01	CJB	A960020	C



THE INFORMATION CONTAINED IN THIS DOCUMENT IS PROPRIETARY TO E-SWITCH AND IS NOT TO BE COPIED OR TRANSFERRED