



CREALITY

# 3D Printer User Manual

3D打印机使用说明书

Ender-3 V2

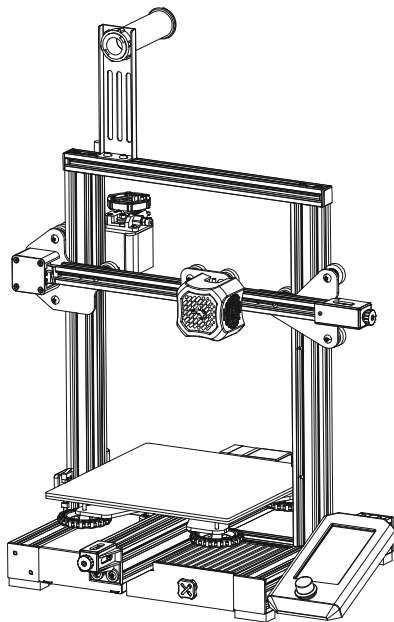

V1.3

# Content 目录

Dear Consumers,

Thank you for choosing our products. For the best experience, please read the instructions before operating the Printer. Our teams will always be ready to render you the best services. Please contact us by phone number or e-mail address provided at the end when you encounter any problem with the Printer.

For a better experience in using our product, you can also learn how to use the Printer in the following ways:

View the accompanied instructions and videos in the TF Card.

Visit our official website [www.creality.com](http://www.creality.com) to find relevant software/hardware information, contact details and operation and maintenance instructions.

尊敬的创想三维用户：

感谢您选择、使用创想三维的产品。为了您使用方便，请您在使用之前仔细阅读该说明书，并严格按照说明书的指示进行操作。

创想三维团队时刻准备为您提供优质的服务。在使用过程中无论遇到什么问题，请按照说明书结尾所提供的电话、邮箱与我们联系。

为了您能够更好地体验我们的产品，您还可以从以下方式获取设备操作知识：

随机使用说明：你可以在TF卡内找到相关使用说明及视频。

创想三维官网：[www.cxsw3d.com](http://www.cxsw3d.com)（您可以登陆创想三维官网寻找相关软硬件、联系方式、设备操作、设备保养等信息）。

## A

### Notes

使用须知

### Product introduction

设备简介

### Spare parts

零部件清单

## B

### Assemble the 3D printer

组装3D打印机

## C

### Use the 3D printer

使用3D打印机

### Start printing

首次打印

### Wire connection

电路接线

### Trouble shooting

故障检修

## NOTES 使用须知

1. Do not use the printer any way other than described herein in order to avoid personal injury or property damage.
2. Do not place the printer near any heat source or flammable or explosive objects. We suggest placing it in a well-ventilated, low-dust environment.
3. Do not expose the printer to violent vibration or any unstable environment, as this may cause poor print quality.
4. Before using experimental or exotic filaments, we suggest using standard filaments such as ABS or PLA to calibrate and test the machine.
5. Do not use any other power cable except the one supplied. Always use a grounded three-prong power outlet.
6. Do not touch the nozzle or printing surface during operation as they may be hot. Keep hands away from machine while in use to avoid burns or personal injury.
7. Do not wear gloves or loose clothing when operating the printer. Such cloths may become tangled in the printers moving parts leading to burns, possible bodily injury, or printer damage.
8. When cleaning debris from the printer hotend, always use the provided tools. Do not touch the nozzle directly when heated. This can cause personal injury.
9. Clean the printer frequently. Always turn the power off when cleaning, and wipe with a dry cloth to remove dust, adhered printing plastics or any other material off the frame, guide rails, or wheels. Use glass cleaner or isopropyl alcohol to clean the print surface before every print for consistent results.
10. Children under 10 years of age should not use the printer without supervision.
11. This machine is equipped with a security protection mechanism. Do not manually move the nozzle and printing platform mechanism manually while booting up, otherwise the device will automatically power off for safety.
12. Users shall comply with related nation and region's laws, regulations and ethical codes where the equipment or produced prints by it is used, and users of our product shall not use aforesaid products to print any end-use products, objects, parts or components or any other physical prints that violate the national or regional laws, regulations and ethical codes where herein referred product and produced prints by it is located.

- 1、请勿尝试任何使用说明中没有描述的方法来使用本机，避免造成的意外人身伤害和财产损失；
- 2、请勿将本机放置在易燃易爆物品或高热源附近，请将本机放置在通风、阴凉、少尘的环境内；
- 3、请勿将打印机放置在振动较大或者其他不稳定的环境内，机器晃动会影响打印机打印质量；
- 4、建议使用厂家推荐耗材，以免造成挤出头堵塞和机器损坏；
- 5、请勿在安装过程中使用其他产品电源线代替，请使用本机附带的电源线，电源插头需接插在带有地线的三孔插座；
- 6、请勿在打印机工作时接触喷嘴以及热床，以防止出现高温烫伤，造成人身伤害；
- 7、请勿在操作机器时佩戴手套或缠绕物，以防可动部件对人身部件造成卷入挤压和切割伤害；
- 8、在打印完毕后及时利用喷头的余温借助工具将喷头上的耗材清理干净，清理时请勿直接用手触摸喷头，以防出现烫伤；
- 9、常做产品维护，定期在断电的情况下，用干布对打印机做机身清洁，拭去灰尘和粘结的打印材料、导轨上的异物；
- 10、年龄在10岁以下的儿童，请勿在没有人员监督的情况下使用本机，以免造成人身伤害；
- 11、本机设有安全保护机制，请勿在开机状态下手动快速移动喷头及打印平台机构，否则设备会自动断电关机保护；
- 12、使用者应遵守设备打印产品与设备所在地及相应国家及地区法律、法规，恪守职业道德，严禁使用我司产品打印有违设备打印产品与设备所在地及相应国家、地区法律禁止的任何产品或物件。



# Equipment parameters

## 设备参数

Basic Parameters 基本参数	
Model   型号	Ender-3 V2
Print size   成型尺寸	220*220*250mm
Forming technology   成型技术	FDM
Number of nozzle   喷头数量	1
Layer thickness   打印层厚	0.1mm-0.4mm
Nozzle diameter   喷嘴直径	Standard   标配 0.4mm
XY axis precision   精度	±0.2mm
Filament   打印材料	Φ1.75mm PLA
File format   支持格式	STL/OBJ/AMF
Working mode   打印方式	Memory card offline printing or online printing   存储卡脱机打印或联机打印
Compatible slicing software   可兼容切片软件	3D Creator Slicer, Repetier-Host, Cura, Simplify3D   创想三维切片软件、Repetier-Host、Cura、Simplify3D
Power specification   电源规格	Input   输入: AC 115/230V 50/60Hz Output   输出: DC 24V
Total power   总功率	350W
Hotbed temperature   热床温度	≤100°C
Nozzle temperature   喷嘴温度	≤250°C
Resume printing function   断电续打	Yes   有
Filament sensor   断料检测	No   不支持
Dual z-axis screws   双Z轴丝杆	No   不支持
Language switch   语言切换	English   中文
Computer operating system   电脑操作系统	Windows XP/Vista/7/10/MAC/Linux
Print speed   打印速度	≤180mm/s, 30-60mm/s normally   ≤180mm/s, 正常为30-60mm/s

# Spare parts

## 主要零部件清单

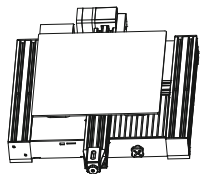

1 Printer base x 1  
底座组件

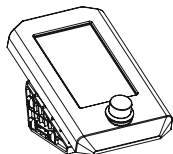

2 Display kit x 1  
显示屏组件

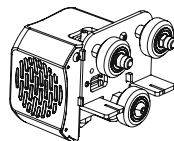

3 Nozzle kit x 1  
喷头套件

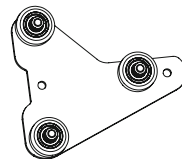

4 Z-axis passive block x 1  
Z轴被动块

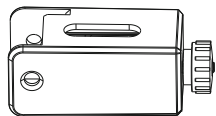

5 X-axis tensioner x 1  
X轴张紧器

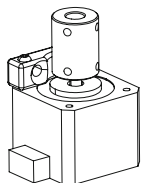

6 Z-axis motor kit x 1  
Z轴电机组件

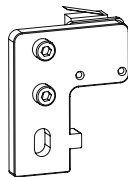

7 Z-axis limit switch kit x 1  
Z轴限位开关组件

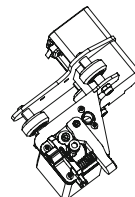

8 XE axis kit x 1  
XE轴组件



9 Z-axis profile(left) x 1  
Z轴型材(左)



10 Z-axis profile(right) x 1  
Z轴型材(右)



11 Gantry profile x 1  
龙门架上型材



12 X-axis profile x 1  
X轴型材

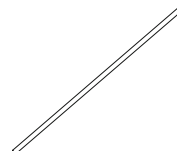

13 T-type screw x 1  
T型丝杆

# Spare parts

## 零部件清单

### Accessory tool list 配件工具清单

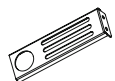

- 14 Material rack x 1  
料架

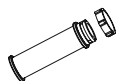

- 15 Material pipe and nut x 1  
料架筒及料架螺母



- 16 2020 profile cover x 2  
2020型材盖



- 17 Synchronous belt x 1  
同步带



- 18 Metal blade x 1  
金属铲刀



- 19 Diagonal pliers x 1  
剪钳



- 20 Cable tie x 1  
扎带



- 21 Needle x 1  
通针

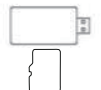

- 22 Storage card and card reader x 1  
存储卡和读卡器



- 23 Pneumatic joint x 2  
气动接头



- 24 Power cable x 1  
电源线



- 25 Wrenches and screwdrivers x 1  
扳手和螺丝刀



- 26 Blue line claw x 2  
蓝色线夹



- 27 Hexagon socket flat round head screw M5X8 x 2  
内六角平圆头螺钉M5X8



- 28 Hexagon socket countersunk head screw M4X18 x 2  
内六角沉头螺钉M4X18



- 29 Hexagon socket head spring washer combination screw M5X25 x 5  
内六角圆柱头弹垫组合螺钉M5X25



- 30 M5T nuts x 2  
M5 T型螺母

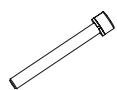

- 31 Hexagon socket head spring washer combination screw M5X45 x 5  
内六角圆柱头弹垫组合螺钉M5X45



- 32 Hexagon socket flat round head spring washer combination screw M4X16 x 5  
内六角平圆头弹垫组合螺钉M4X16



- 33 Filament x 1  
耗材



- 34 Indication knob x 1  
指示旋钮



- 35 Hexagon socket countersunk head screw (black) M4X14 x 1  
内六角沉头螺钉(黑)M4X14



- 36 Nozzle x 1  
喷嘴

# 1

## Installation of Z-axis limit switch kit and Z-axis profiles

安装Z轴限位开关组件，Z轴型材

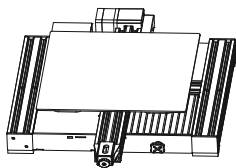

1 Printer base x 1  
底座组件



9 Z-axis profile(left) x 1  
Z轴型材(左)



10 Z-axis profile(right) x 1  
Z轴型材(右)



7 Z-axis limit switch kit x 1  
Z轴限位开关组件



31 Hexagon socket head spring washer combination screw  
M5X45 x 4 内六角圆柱头弹垫组合螺钉M5X45

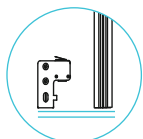

Install Z-axis limit switch aligning with the profile.  
安装Z轴限位开关，与型材对齐

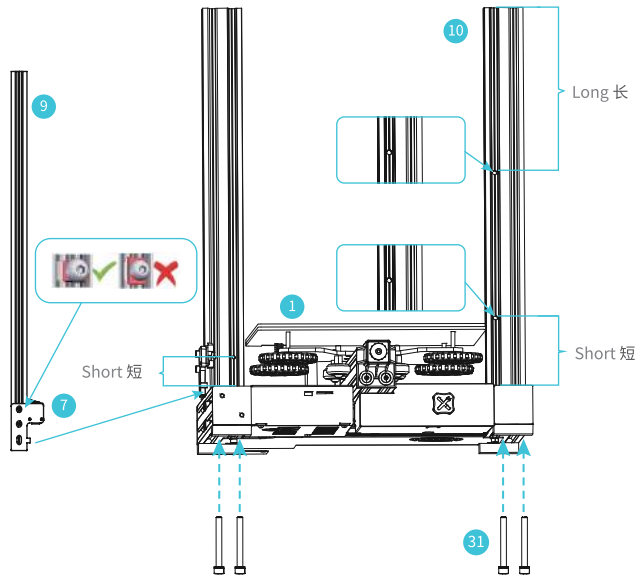

Step: Put the endstops sensor on Z-axis (left) like the picture above. Then use the four pieces screw M5X45 to fix Z-axis with the base.

步骤：把限位传感器安装到Z轴型材（左）如上图，用4颗内六角圆柱头弹垫组合螺钉M5X45将Z轴型材锁紧在底座组件上。



## 2

# Install Z-axis motor kit and t-type screw

安装Z轴电机组件、T型丝杆

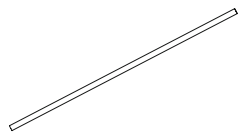

13 T-type screw x 1  
T型丝杆

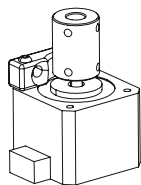

6 Z-axis motor kit x 1  
Z轴电机组件

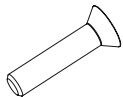

28 Hexagon socket countersunk  
head screw M4x18 x 2  
内六角沉头螺钉M4X18

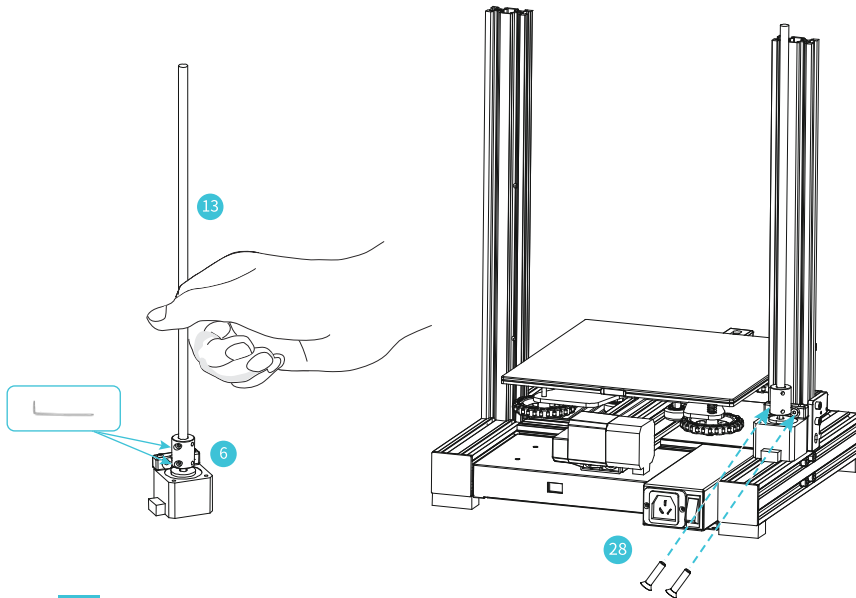

Steps: Lock the T-shaped screw rod on the Z-axis motor component, and then use two M4X18 screws to slightly lock the Z-axis motor component on the profile (as shown above)

步骤：把T型丝杆锁定在Z轴电机组件上，然后用两颗M4X18螺钉将Z轴电机组件微锁定在型材上（如上图示）。

# 3

## Install pneumatic joint, XE-axis kit and synchronous belt

安装气动接头、XE轴组件、同步带

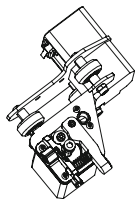

8 XE axis kit x 1  
XE轴组件



12 X-axis profile x 1  
X轴型材



23 Pneumatic joint x 1  
气动接头



32 Hex socket flat round head spring washer combination screw M4X16 x 2  
内六角平圆头弹垫组合螺钉 M4X16



17 Synchronous belt x 1  
同步带



25 Open-end wrench x 1  
开口扳手

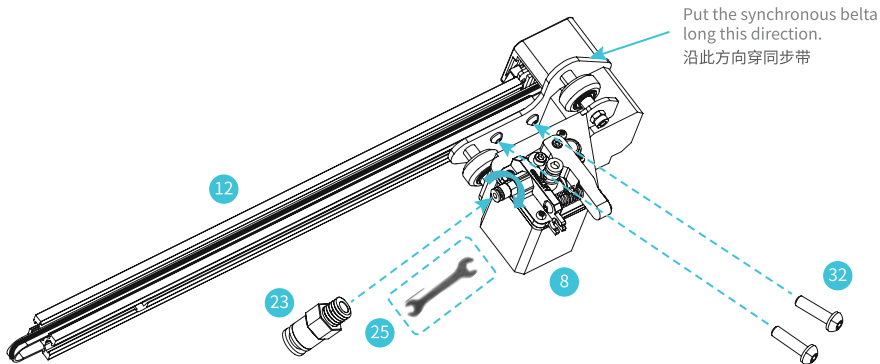
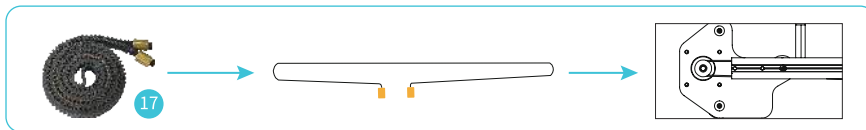

Step: Tighten the tube connector by open end wrench. And fix the XE-axis kit with two pieces M4\*16 screw. Put the timing belt through the XE-axis kit with direction same as the picture.

步骤：装气动接头时用开口扳手拧紧；用两颗M4X16螺钉，将XE轴组件固定在型材上；将同步带穿过XE轴组件(注意同步带方向)如上图示。

## 4

## Install Nozzle kit, Z-axis passive block

安装喷头套件、Z轴被动块

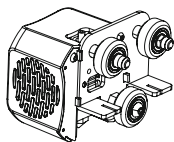

3 Nozzle kit x 1  
喷头套件

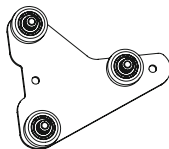

4 Z-axis passive block x 1  
Z轴被动块



32 Hexagon socket flat round head  
spring washer combination screw  
M4X16 x 1 内六角平圆头弹垫组合螺钉  
M4X16

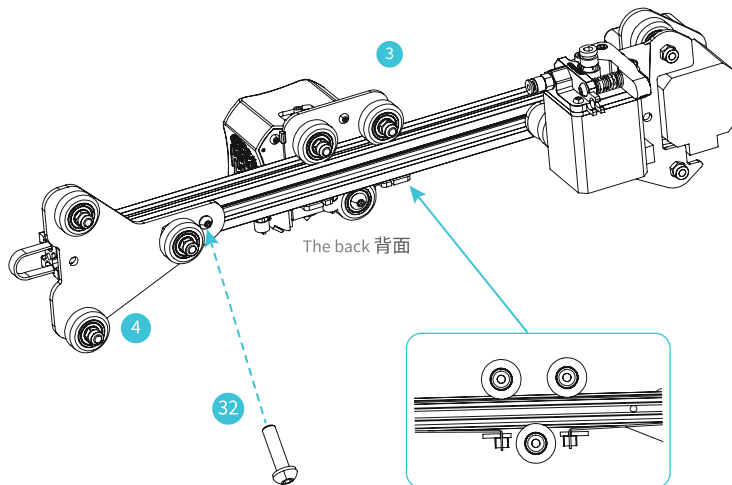

Steps: Put the synchronous belt into the profile along the v-wheel of the nozzle kit . When pushing it into the middle, as shown in the figure; lock the z-axis passive block with one M4×16 screw.

步骤：将同步带贴紧型材同时沿着喷头套件的V轮套进型材，推入中段，如上图示；用1颗M4X16圆头螺钉将Z轴被动块锁住。

# 5

## Install X-axis Tensioner

安装X轴张紧器

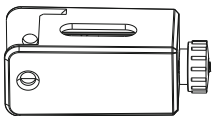

5 X-axis tensioner x 1  
X轴张紧器



32 Hexagon socket flat round head  
spring washer combination screw  
M4X16 x 1 内六角平圆头弹垫组合螺  
钉M4X16



35 Hexagon socket countersunk  
head screw (black) M4X14 x 1  
内六角沉头螺钉 (黑) M4X14

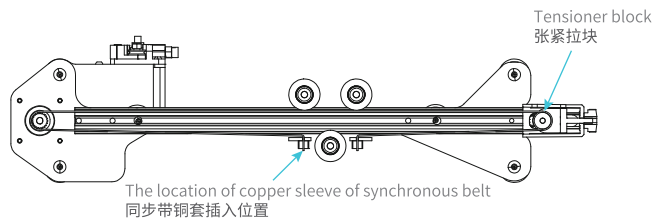
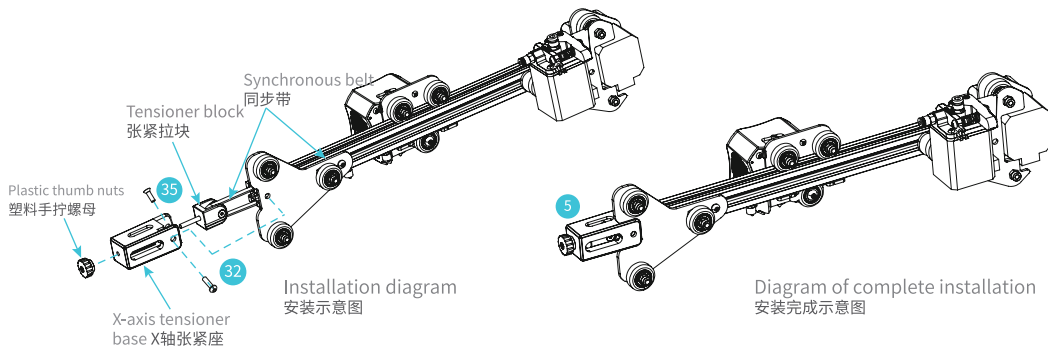

Section diagram of synchronous belt moving 同步带走线剖面示意图



Steps: Insert the timing belt into the tensioner block, and put it into the X-axis tensioner together with the timing belt, tighten it with a plastic hand screw nut, lock Z-axis passive block with one M4X16 screw, and then lock the M4X14 screw.

步骤: 将同步带插入张紧拉块, 连同同步带一起套进X轴张紧器, 将塑料手拧螺母拧住; 用1颗M4X16螺钉将它锁紧在Z轴被动块上, 然后锁紧M4X14螺钉。

## 6

# Install the z-axis moving kit and adjust the tightness of X-axis and Y-axis tensioners

安装Z轴移动组件,调节X、Y轴张紧器松紧度

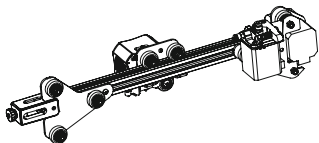

Take the fifth step: assembled components  
承接第五步:装好的组件

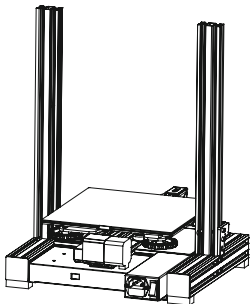

Take the second step: assembled components  
承接第二步:装好的组件

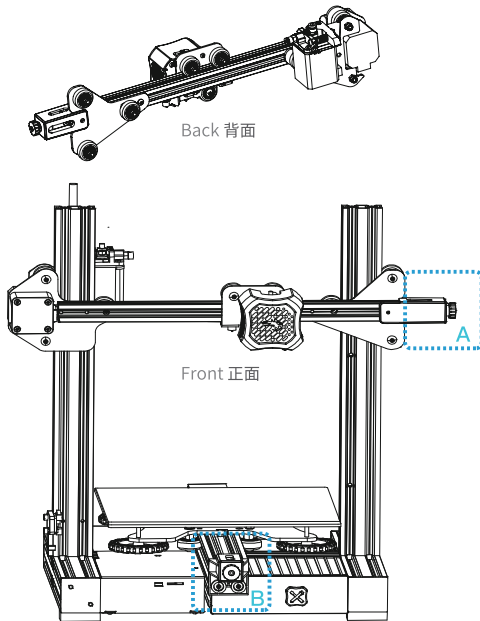

**⚠**

A B

Tips: manually rotate the X-axis and Y-axis tensioners to be the appropriate tightness. Refer to A: the difference between the nut and the screw (protrusion) is 0-3mm. The reference standard is to press the synchronous belt with a little tension. Too loose or tight belt will affect the printing effect, and too tight belt will break. Refer to B: nut flush with screw.

提醒:手动将X、Y轴张紧器旋转到合适的松紧度, A参考:螺母与螺钉(凸出)相差0~3mm,具体以手轻按压同步带有一点张力为参考标准,过松、过紧均会影响打印效果,同时过紧可能会造成同步带崩断, B参考:螺母与螺钉齐平。



Steps: Make the Z-axis moving kit insert the two ends of the Z-axis profile along V-wheel on both sides. As shown in the figure above. The profile moves smoothly up and down along the Z-axis, and it will not fall off by itself.

步骤:将Z轴移动组件,沿着两边V轮插入Z轴型材两端(如上图所示),沿着Z轴型材上下活动顺畅,不会自然跌落。

## 7

## Install the gantry profile, display kit

安装龙门架上型材、显示屏组件

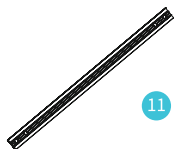

11 Gantry profile x 1  
龙门架上型材

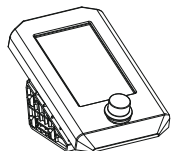

2 Display kit x 1  
显示屏组件



29 Hexagon socket head spring  
washer combination screw  
M5X25 x 4 内六角圆柱头弹垫组  
合螺钉 M5X25

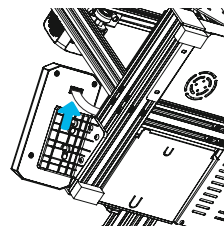
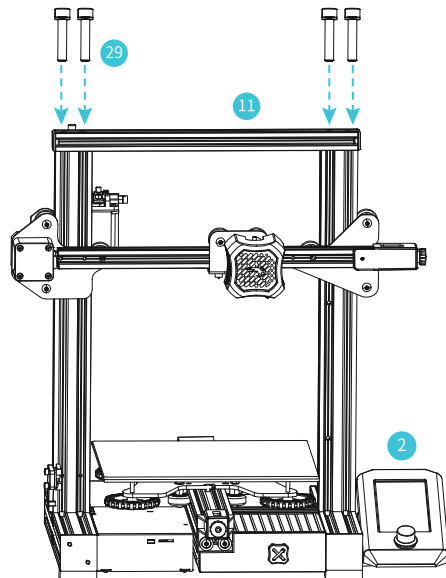

Connect the display cable  
连接显示屏线

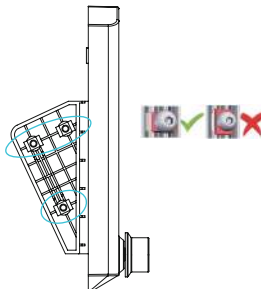

Steps: Install the profile of the gantry frame on the upper of the gantry frame with 4 M5X25 hexagon socket head spring combination screws; firstly connect the display cable, then use the hex wrench to fix the 4 screws on the left side of the display module with the machine, locked the screws as well.

步骤:用4颗内六角圆柱头弹垫组合螺钉M5X25将龙门架上型材固定在龙门架上端;先将显示屏线连接好,再用内六角扳手将显示屏组件左侧4颗螺丝与机器锁紧即可。

## 8

## Install material rack, gantry profile cover and indication knob

安装料架、型材盖、指示旋钮

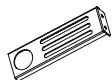

- 14 Material rack x 1  
料架

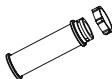

- 15 Material pipe and nut x 1  
料架筒及料架螺母



- 16 2020 profile cover x 2  
2020型材盖



- 27 Hexagon socket flat round  
head screw M5X8 x 2  
内六角平圆头螺钉M5X8



- 30 M5T nut x 2  
M5 T型螺母



- 34 Indication knob x 1  
指示旋钮

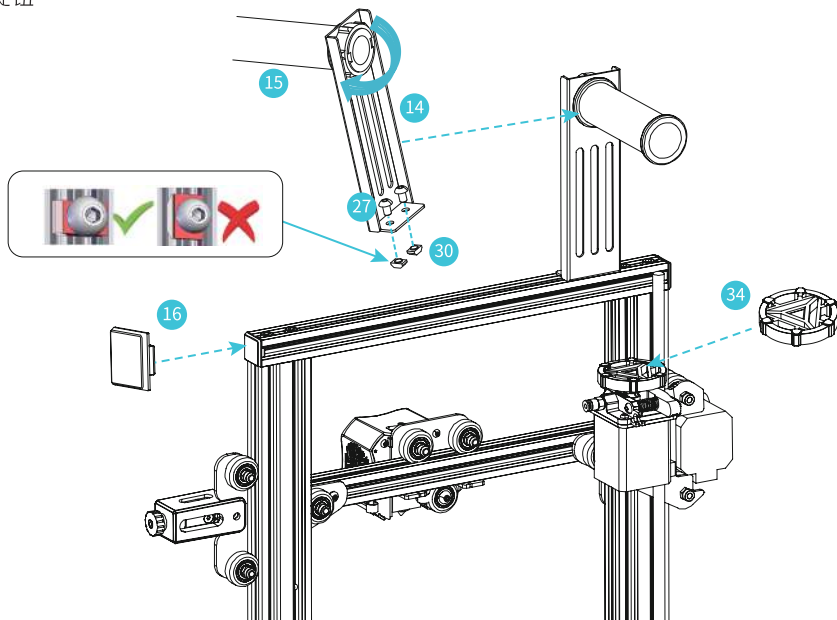

Steps: Put flat round head M5X8 and M5T screws into the material rack(as shown), place the spool holder on the rack and fix on the profile with screws(as shown); Put the indication knob on the motor shaft and then place the 2020 profile cover on both side.

步骤:将平圆头螺钉M5X8及M5T型螺母安装与料架上(如上图示),把料架筒装与料架上并拧上料架螺母,最后固定于型材上(如上图示);将指示旋钮直接套入电机轴,按上左右两边的2020型材盖。

# 9

## Wire connection 设备接线

Connect X, E, Z-axis stepper motors according to the yellow label on the 6pin (4 wires) port 按照6pin (4根线) 端口上黄色标签提示连接X、E、Z轴步进电机  
 Connect X, Z-axis limit switches according to the yellow label on the 3pin (2wires) port 按照3pin (2根线) 端口上黄色标签提示连接X、Z轴限位开关  
 Plug in the power cord (as shown) and toggle the switch to turn on the power 插上电源线 (如示意图) 拨动开关打开电源



24 Power cable x 1  
电源线



26 Blue wire clip x 1  
蓝色线夹

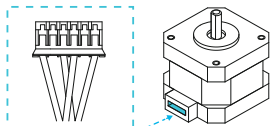

X, E, Z-axis motor port  
X、E、Z轴电机接口

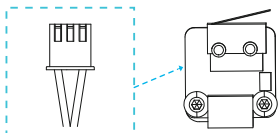

X, Z-axis limit switch  
X、Z轴限位开关

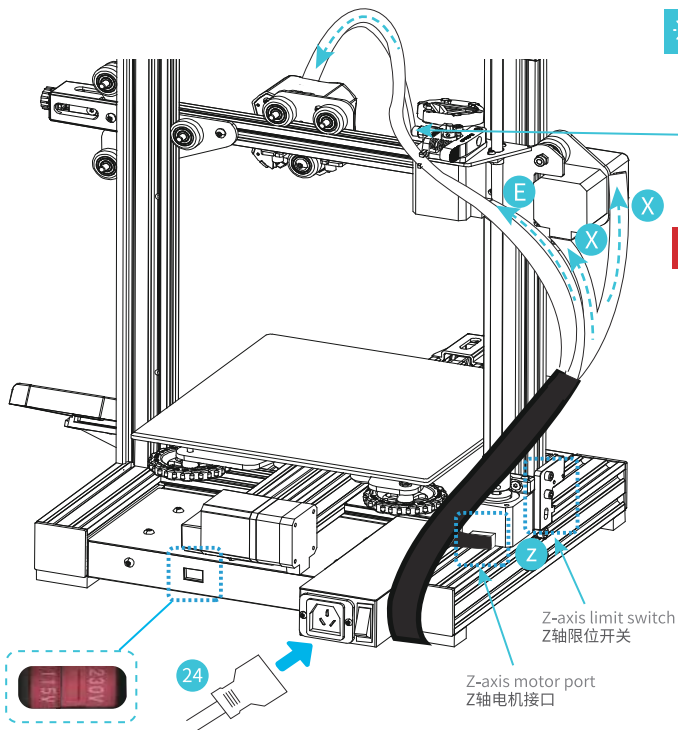

Insert the Teflon tube into the pneumatic connector (also insert the blue wire clamp)  
 将铁氟龙管插入气动接头(同时插入蓝色线夹)



### Caution

- Select the correct input voltage to match your local mains (115/230V)
- Damage can occur if voltage is set incorrectly.
- Connect the power cord and turn the power switch to 1 to turn it on.
- 选择正确的输入电压以匹配您的本地电源。(115/230V)
- 如果电压设置不正确, 可能会造成损坏。
- 连接电源线并将电源开关拨至1档即可开机。

Do not connect or disconnect the cables when the machine is powered on.  
 当机器通电时, 请勿连接或断开连接线。



## 10

## Bed Leveling 调平台



Twist the coupling to raise the X axis to the position as picture shown. During the leveling process, please do not touch the Teflon tube and nozzle cable.

确认喷嘴回到原点，方可关闭电机；调平过程中，请不要触碰磁氟龙管及喷头排线。

# 11

1. Move the nozzle near the top of the leveling nut. Screw the nut and adjust the distance between the nozzle and the printing platform. The distance is about 0.1mm. (Thickness of a piece of A4 paper)
  2. We can use a piece of A4 paper to assist in leveling, so that the nozzle can just scratch the A4 paper. Adjust the leveling nuts on the four sides in turn until you can feel the slight resistance from the nozzle when pulling the A4 paper.
  3. Test the distance between the nozzle and the print platform is enough or not. Repeat the above steps 1-2 times if necessary.
- 1.移动喷嘴至调平螺母上方附近。拧动螺母，调节打印平台喷嘴使二者处于好贴合状态，间距约为0.1mm。（一张A4纸的厚度）
  - 2.我们可以利用一张A4纸辅助调平，使喷嘴刚好能在A4纸上产生划痕。依次完成四个边上上调平螺母的调节，不断调整直到在拉动A4纸时能感受到来自喷嘴的轻微阻力。
  - 3.测试平台中间间隙是否合适，如有必要可重复上述步骤1-2次。

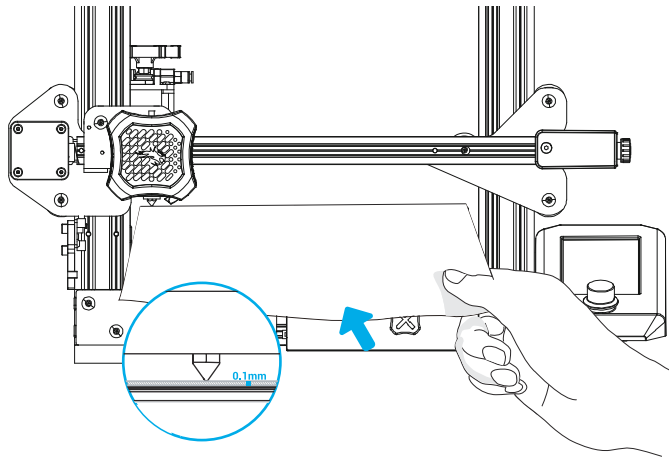
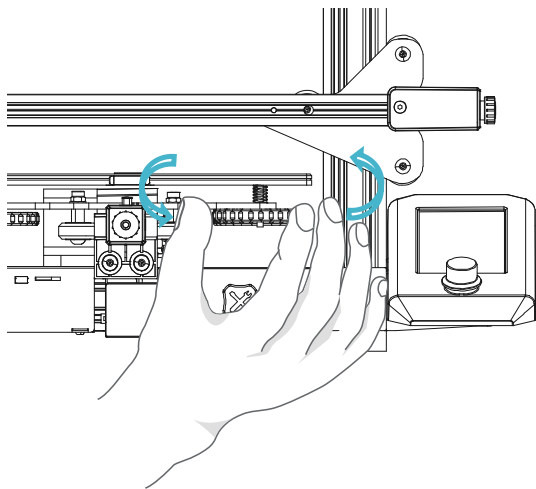

				<p>The nozzle is too far away from the platform, so the consumables can not adhere to the platform. 喷嘴离平台太远，耗材无法粘附在平台上。</p>			<p>The nozzle is too close to the platform, the filaments are not extruded sufficiently, and the nozzle is damaged to result in plug. It's easy to scratch the printing platform. 喷嘴离平台太近，耗材挤出不足，喷嘴出口损伤，造成堵头，刮伤打印平台。</p>
				<p>The even filament adheres right on the platform. 耗材挤出饱满均匀，刚好贴在平台上。</p>			

# 12

## Preheat

预热

Method 1



方法1



Note: The UI information is only for reference, the actual UI may be different.  
注意：界面仅供参考，实际以UI为准。

# Preheat

## 预热

Method 2



方法2



Note: The print preheating standard is adjusted at the factory, PLA preheating standard: nozzle temperature 200 °, hot bed temperature 60°, ABS preheating standard: nozzle temperature 240°, hot bed temperature 70°.

If you need to adjust it due to printing materials or other reasons, you can adjust the parameters on the interface home page control → temperature → PLA / ABS preheat setting.

注意：打印预热参数标准出厂时已调整好，PLA预热标准：喷嘴温度200°，热床温度60°，ABS预热标准：喷嘴温度240°，热床温度70°。若因打印材料或其他原因需要调整，可以在界面首页控制→温度→PLA/ABS预热设置进行参数调整。

# 13

## Load the filament

装料

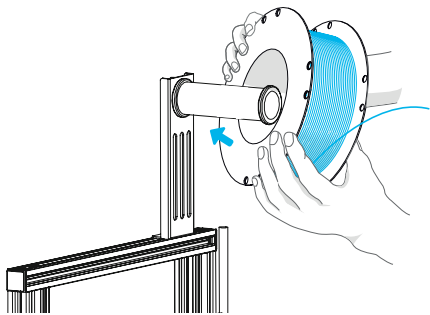

1、When waiting for the temperature to rise, please hang the filaments on the material rack.  
当您在等待温度上升时,把耗材挂在料架上。

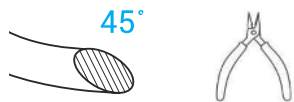

For better printing, the end of filament is as shown in the figure.

为了顺利完成打印,耗材的末端位置应,如图所示。

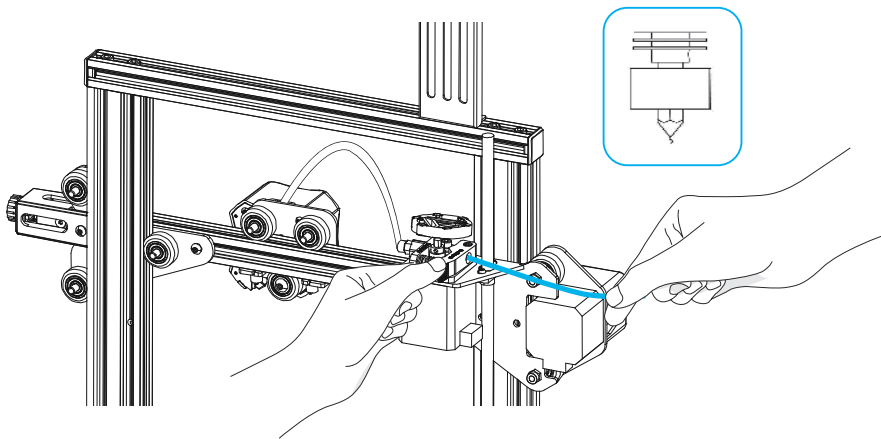

2、Press the extrusion spring and insert the filament until the nozzle along the extrusion. When the temperature is up to the target temperature, the filament will come out of the nozzle, nozzle, and complete loading the filament.

按住挤出弹簧,将耗材沿着挤出机孔插入直至喷嘴位置。当温度达到设定目标值时,可以看到喷嘴处有耗材流出,装载完成。



Replace the filament:

- 1.If no filament in the nozzle, cut the filament at the extruder, put the new filament into the tube, and until the filament arrives on the feeding tube.
- 2.If filament in the nozzle, heat up the nozzle to 185°+, draw out the filament, and then replace the filament according to step 1.
- 3.If replace the filament during the printing process,adjust the printing speed to 10%, and then replace the filament according to step 2.

更换耗材:

- 1、设备刚开始打印,在靠近挤出机处将耗材剪断,将新耗材缓缓送入,直到耗材被送入导料管为止。
- 2、设备已打印且冷却了,需要将喷嘴加热到185°+,再将耗材抽出,再参考步骤1更换耗材。
- 3、打印过程中更换耗材,把打印速度设置调节为10%,参照步骤2更换耗材。

# 14

## Start printing

首次打印

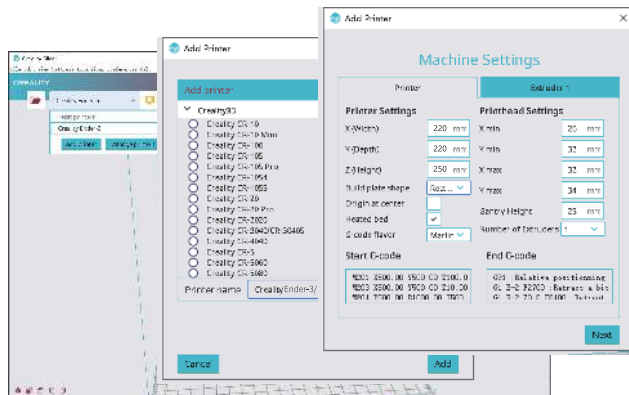

3. Select language→Next→Select your machine→Next→Finish.



1. Double click to install the software. | 安装软件
2. Double click to open the software. | 打开软件



3. 依次选择语言→Next→选择对应机型→Next→Finish, 完成设置。

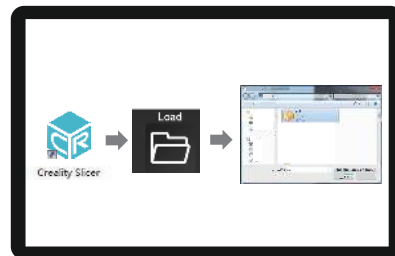

4. Open Creaty 3D slicer → Load (Read file) → Select file.  
打开创想三维切片软件→Load (读取文件) → 选择文件。

## Start printing 首次打印

When printing for the first time, please level the platform first, otherwise it will easily cause nozzle damage, plug and scratch the printing platform.  
首次打印时, 请先调平, 否则容易造成喷头损伤、堵头, 刮坏打印平台。

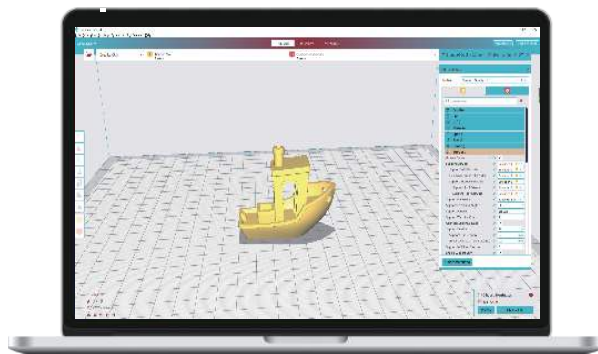

5. Generate G-code, and save the gcode file to TF card.  
生成 G 代码 → 保存到 TF 卡

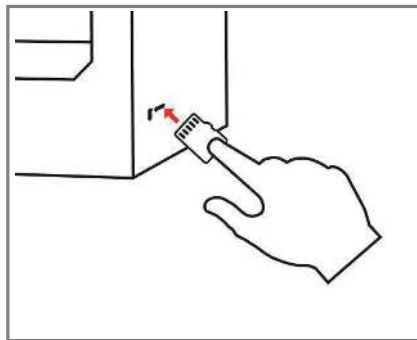

6. Insert the TF card → press the knob → select the menu  
→ the file to be printed.  
插入 TF 卡 → 按下旋钮 → 选择菜单 → 要打印的文件



File names must be Latin letters or numbers, not Chinese characters or other special symbols.  
文件名需为拉丁字母或数字, 不能为汉字或其他特殊符号。



Notes: For details on the software instructions, please refer to the slicing software manual in the memory card!  
温馨提示: 软件使用说明详情, 请见存储卡内切片软件使用手册!

# Start printing

首次打印

Print

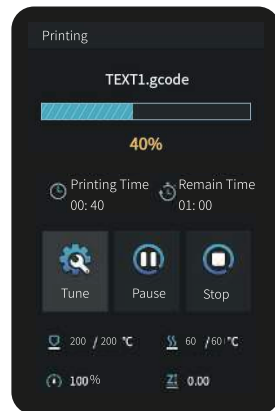

打印





# Wiring connection

电路接线

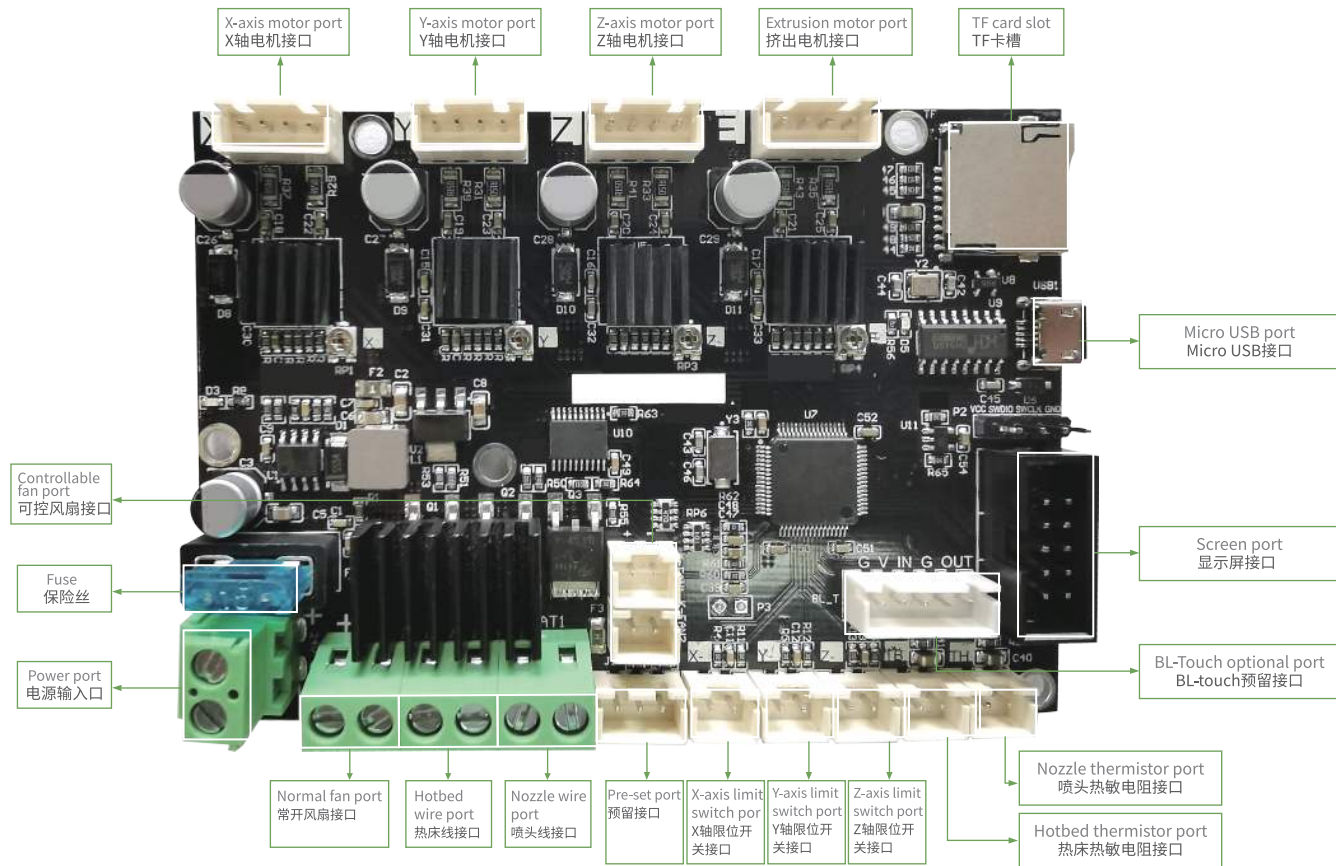

# Trouble shooting

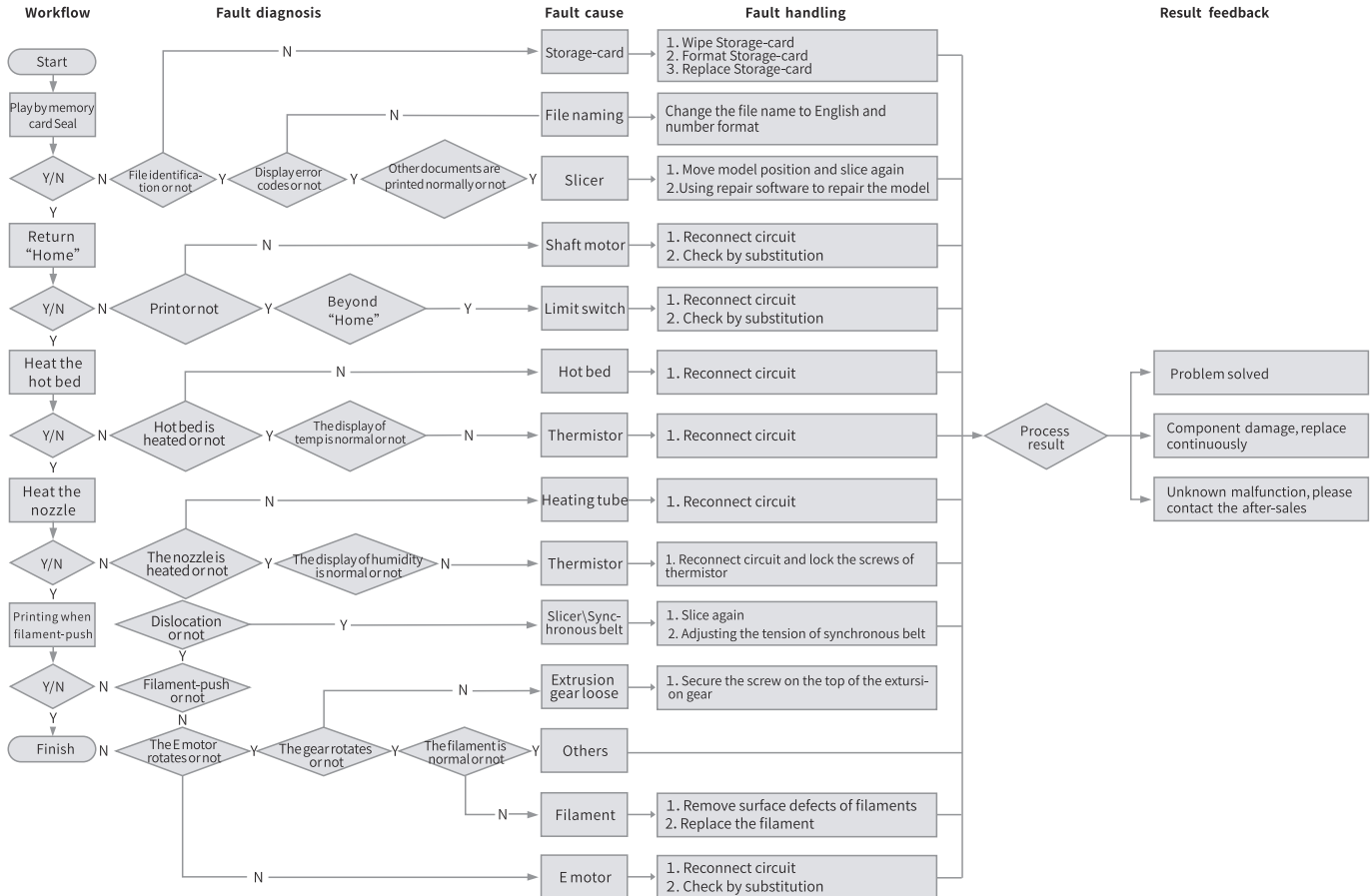

# 故障检修

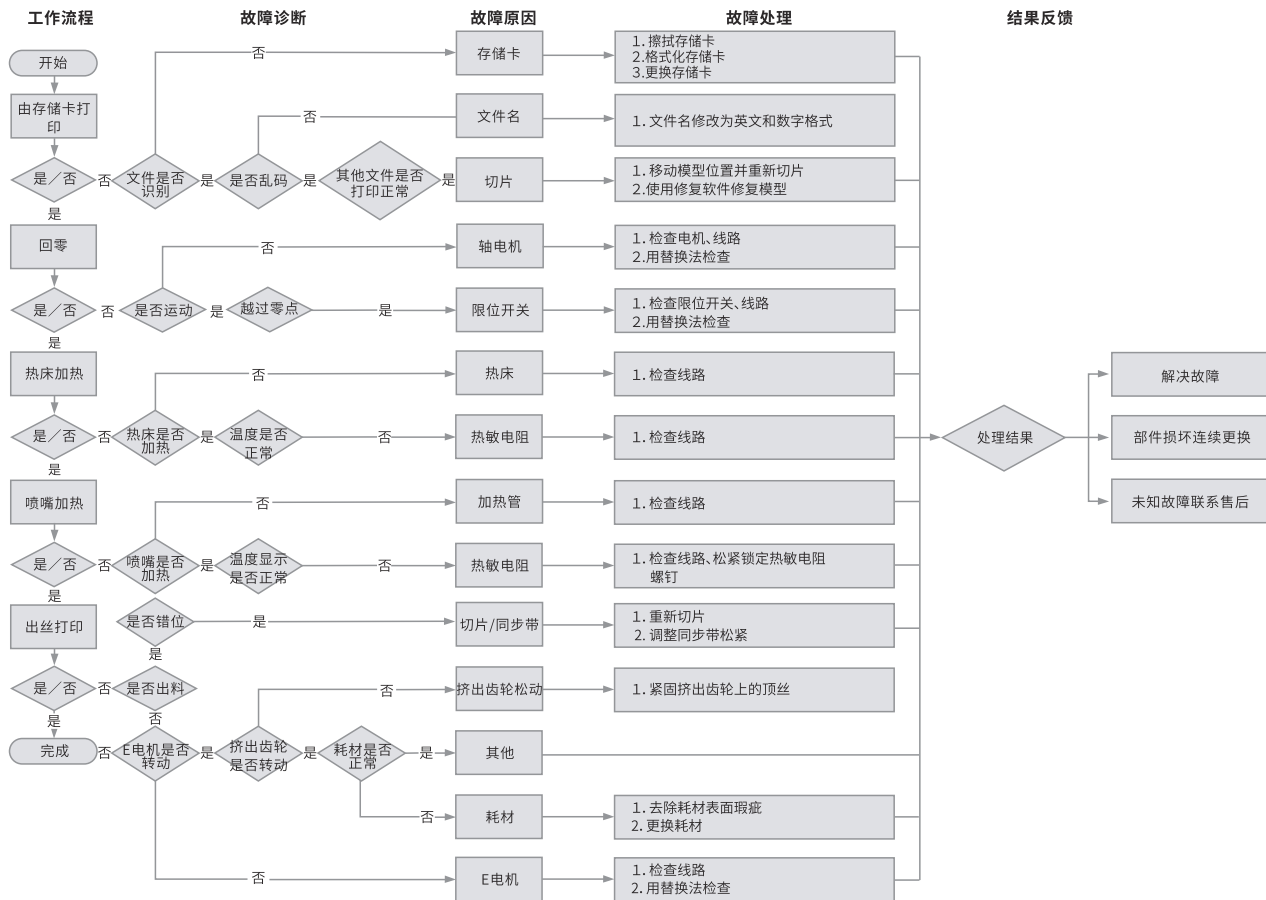

Due to the differences between different machine models, the physical objects and the final images can differ. The final explanation rights shall be reserved by Shenzhen Creality 3D Technology Co., Ltd.

因每款机型不同,实物与图可能有所差异, 请以实物为准, 最终解释归深圳市创想三维科技有限公司所有。



### SHENZHEN CREALITY 3D TECHNOLOGY CO.,LTD.

11F & Room 1201,Block 3,,JinChengYuan,Tongsheng Community,

Dalang,Longhua District,Shenzhen,China,518109

Official Website: [www.creality.com](http://www.creality.com)

Tel: +86 755-8523 4565

E-mail: [info@creality.com](mailto:info@creality.com) [cs@creality.com](mailto:cs@creality.com)



### 深圳市创想三维科技有限公司

深圳市龙华区大浪街道同胜社区金城工业园第三栋1201、11层

公司网站: [www.cxsw3d.com](http://www.cxsw3d.com)

服务热线: 400 6133 882

0755-8523 4565

